

HOMELAND DEFENSE/ NEIGHBORHOOD IMPROVEMENT BOND OVERSIGHT BOARD AGENDA

3/23/10 – 6:00 P.M.
CITY OF MIAMI
CITY HALL CHAMBERS
3500 PAN AMERICAN DRIVE
MIAMI, FLORIDA 33133

I. APPROVAL OF THE MINUTES FOR THE MEETING OF FEBRUARY 23, 2010.

II. NEW BUSINESS:

Introduction of New Board Members:

- Enrique (Henry) J. Zayas-Bazan nominated by Mayor Tomas Regalado
- David Willig nominated by Chairman Marc Sarnoff
- Mariano Cruz nominated by Commissioner Wifredo (Willy) Gort

III. NEW ITEMS:

1. Pier Line Repairs at MiaMarina
2. Pierce Arrow XT Special Response Vehicle
3. Bicentennial Park/Museum Park Mooring Bollards
4. New Gibson Park – Design Services

IV. NEW INFORMATION ITEM:

1. Land Acquisition – 1814 Brickell Avenue

V. PROJECT UPDATES:

1. Defense and Security Equipment Acquisition
2. Dinner Key Mooring Field
3. Dinner Key Mitigation
4. Marine Stadium Marina Boat Rack Metal Roof Deck
5. MiaMarina Emergency Repairs Pier No. 5
6. Merrie Christmas Park New Swings
7. Police Department Property Unit Outdoor Storage
8. Tamiami Storm Sewer Improvements – Construction Services

VI. OLD BUSINESS - FOLLOW UP ITEMS FROM 2/23/10 MEETING:

1. How many acres of park land have been purchased with HD funds?
2. Is there a plan for acquisition of new park land?
3. NE 2nd Avenue Project Presentation.
4. How many dollars have been spent to date on projects whose funds increased due to design modification required by FDOT?
5. Cost paid to contractor to date for Roberto Clemente Park/New Dorothy Quintana Community Center.
6. Updated spreadsheet of all HD dollars.
7. Request for Parks' Director or his designee to be in attendance in all future BOB Meetings to answer any maintenance/operations questions.

VII. CHAIRMAN OPEN AGENDA:

VIII. ADDITIONAL ITEMS:

HOMELAND DEFENSE/
NEIGHBORHOOD IMPROVEMENT
BOND OVERSIGHT BOARD
MINUTES

2/23/10 – 6:00 P.M.
CITY OF MIAMI
CITY HALL CHAMBERS
3500 PAN AMERICAN DRIVE
MIAMI, FLORIDA 33133

The meeting was called to order at 6:14 p.m., with the following members found to be

Present: Eileen Broton
Henry Goa
Ricardo Lambert
Pablo Perez-Cisneros
Robert Powers
Gary Reshefsky
Beba Sardiña Mann
Jose Solares (Chairman)

Absent: Hugo P. Arza
Rolando Aedo (Vice Chairman)
Hattie Willis

ALSO PRESENT: Ola O. Aluko, Director, CIP Department
Robin Jones-Jackson, Assistant City Attorney
Ed Blanco, Project Supervisor, Parks & Recreation
Sandra Vega, Project Manager, CIP Department
Gilbert Henric, Project Manager, CIP Department
Hector Badia, Project Manager, CIP Department
Danette Perez, Board Liaison, CIP Department
Marcia Lopez, Public Relations Specialist, CIP Department
Teri-Elizabeth Thomas, City Clerk's Office

I. APPROVAL OF THE MINUTES FOR THE MEETING OF JANUARY 26, 2010

HD/NIB MOTION 10-11

A MOTION TO APPROVE THE MINUTES OF THE MEETING OF JANUARY 26, 2010 WITH THE CLARIFICATION THAT THE FUNDS APPROVED BY THE BOARD TO BE TRANSFERRED FROM THE KINLOCH STORM WATER PROJECT TO THE MUSEUM PARK PROJECT WERE NEVER TRANSFERRED AND THE FUNDS REMAIN PART OF THE KINLOCH STORM WATER PROJECT.

MOVED: E. Broton
SECONDED: R. Powers
ABSENT: R. Aedo, H. Arza, H. Willis

Note for the Record: Motion passed by unanimous vote of all Board Members present.

II. NEW BUSINESS:

Introduction of New Board Member:

- Beba Sardiña Mann nominated by Mayor Tomas Regalado

Chairman Solares welcomed Beba Sardiña Mann as a new board member nominated by Mayor Tomas Regalado.

III. NEW INFORMATION ITEMS:

1. Kennedy Park New Rubber Surface Walking Trail

NAME OF PROJECT: KENNEDY PARK NEW RUBBER SURFACE WALKING TRAIL
TOTAL DOLLAR AMOUNT: \$291,000
SOURCE OF FUNDS: <u>District 2 Quality of Life</u>
ACCOUNT CODE(S): <u>331419</u>
DESCRIPTION OF PROJECT: <u>Installation of new rubber surface walking trail.</u>

HD/NIB MOTION 10-12

A MOTION TO FUND THE KENNEDY PARK NEW RUBBER SURFACE WALKING TRAIL,

MOVED: P. Perez-Cisneros
SECONDED: R. Powers
ABSENT: R. Aedo, H. Arza, H. Willis

Note for the Record: Motion passed by unanimous vote of all Board Members present.

2. Marjorie Stoneman Douglas Park New Rubber Surface for Swings

NAME OF PROJECT: MARJORIE STONEMAN DOUGLAS PARK NEW RUBBER SURFACE FOR SWINGS
TOTAL DOLLAR AMOUNT: \$45,000
SOURCE OF FUNDS: <u>District 2 Quality of Life</u>
ACCOUNT CODE(S): <u>331419</u>
DESCRIPTION OF PROJECT: <u>Installation of new rubber surface for swings.</u>

HD/NIB MOTION 10-13

A MOTION TO FUND THE MARJORIE STONEMAN DOUGLAS PARK NEW RUBBER SURFACE SWINGS.

MOVED: R. Powers
SECONDED: R. Lambert
ABSENT: R. Aedo, H. Arza, H. Willis

Note for the Record: Motion passed by unanimous vote of all Board Members present.

IV. NEW ITEMS:

1. Coral Gate Park New Community Building – Construction Services

<p>NAME OF PROJECT: <u>CORAL GATE PARK NEW COMMUNITY BUILDING – CONSTRUCTION SERVICES</u></p> <p>TOTAL DOLLAR AMOUNT: <u>\$1,683,307 (Total HD funds \$1,063,180 and Sunshine State Financing Commission \$75,000)</u></p> <p>SOURCE OF FUNDS: <u>Neighborhood Park Improvements & Sunshine Sate Financing Commission</u></p> <p>ACCOUNT CODE(S): <u>331419 & 888961</u></p> <p>DESCRIPTION OF PROJECT: <u>The project consists of furnishing all labor, materials and equipment for the construction of a new community building of approximately 4,600 sq.ft. of gross area. Also, the project includes a new parking lot, landscape, irrigation, demolition of existing building, relocation of existing playground, possible utility off-site improvements and site lighting. The project will use the design space program of Grapeland Recreational Building.</u></p>

HD/NIB MOTION 10-14

A MOTION TO FUND THE CORAL GATE PARK NEW COMMUNITY BUILDING - CONSTRUCTION SERVICES.

MOVED: R. Powers
SECONDED: P. Perez-Cisneros
ABSENT: R. Aedo, H. Arza, H. Willis

Note for the Record: Motion passed by unanimous vote of all Board Members present, with the exception of Chairman Solares and Gary Reshefsky voting no.

V. PROJECT UPDATES:

1. Coral Gate Park New Community Building – Design Services

This update was combined with the discussion of the new item, Coral Gate Park New Community Building - Construction Services.

Sandra Vega, CIP Department, stated that the design of the building was near completion, but a new change was introduced and now a new proposal needs to be requested and then negotiate the cost of including the design of the NET office.

2. Roberto Clemente Park New Recreation Building – Dorothy Quintana Community Center

Ola Aluko, CIP Director, stated that the project is roughly 80 percent complete. The project completion is expected in June 2010. Once completed, this will be the City’s second LEED-certified facility. The facility is 9,000 square feet. At one point, the facility housed a 1,200 square foot NET office, but due to

budgetary issues, the NET offices were consolidated so the NET office was changed into a meeting room for the Parks Department. Pablo Perez-Cisneros requested the cost paid to the contractor to date.

3. NE 2nd Avenue Improvements- Design Services

Ola Aluko, CIP Director, stated that the project has multiple phases. The Homeland Defense dollars are only funding the segments between 36th Street and 78th Street. Segment B1 has been bid and is expected to go into construction March 2010. Segment C has been bid and is expected to go into construction in March 2010. At the next meeting on the project, a visual presentation will be made to show the Board what the project will look like once it's completed.

Hector Badia, Project Manager, CIP Department, stated that the scope of work on 36th Street to 42nd Street is milling and resurfacing, sidewalk repairs and some landscaping. The cost is minimal and the length is approximately 1,300 feet. Segment C is complete road reconstruction, signalization, lighting, landscaping, pavement, and adding bike lanes. Segment A is still in the design stage.

4. Robert King High Park New Building & Site Improvements – Additional Funding

Ola Aluko, CIP Director, stated that the project is going into construction. This is one of the projects where the budget was more than what was needed. The excess dollars are intended to be used for the shortfall on Coral Gate since both projects are in the same district. The project is expected to be completed within the next 11 months.

Robert Powers requested that the CIP Director provide the Board with a list of properties that have been purchased with Homeland bond funds for use as parkland.

5. Athalie Range Park Soccer/Football Field Improvements

Note: Chairman Solares stated that he had a conflict of interest and recused himself from the discussion of this update.

Ola Aluko, CIP Director, stated that the project has moved into construction and is about to break ground. The project had competitive bidding and the price came in at \$1.34 million. The demolition portion of the project is 80 percent completed. The project as a whole is roughly 15 percent completed. The project is expected to be completed no later than December 2010.

6. Henderson Park New Offices/Restroom Facility – Additional Funding

Ola Aluko, CIP Director, stated that the project is very near completion. Completion is expended on the project in March 2010. The project scope consisted of a park office, restrooms, concession facility, maintenance facility, resurfacing of tennis courts, basketball courts, and other landscaping. The construction cost was \$789,000.

VI. FOLLOW UP ITEMS FROM 1/26/10 MEETING:

- Robin Jones-Jackson, Assistant City Attorney

Robin Jones-Jackson stated that the information requested by the Board at the previous meeting was including in the board meeting packages for tonight's meeting.

Staff will be contacting each board member regarding their availability in March or April to have a Sunshine Law and City Conflict of Interest and Cone of Silence workshop. This will be a properly noticed public workshop.

VII. CHAIRMAN OPEN AGENDA:

VIII. ADDITIONAL ITEMS:

- Miami Circle Project

Ola Aluko stated that the District 2 Commissioner would like to utilize \$50,000 from his quality of life allocation towards the Miami Circle Project development. The funds may be expended or committed prior to the next board meeting. At the next audit subcommittee meeting, the proper documents will be provided and there will be a meeting with the City Attorney with regards to the eligible use of the dollars.

- Status of Homeland Defense Funds

Pablo Perez-Cisneros requested a list of the current status of the Homeland Defense funds that reflects the funding that has been expended and where the funds have been spent.

Ola Aluko, CIP Director, stated that the information is available but the format is difficult to comprehend. He stated that the Department is currently simplifying the information for the Board's use and the new document will be provided to the Board.

- Accomplishments Pamphlet

Ola Aluko, CIP Director, stated that the CIP Department has created an accomplishments booklet/pamphlet to share with the Board. It shows what CIP has done with the Homeland Defense dollars since its inception. If funding permits, the pamphlet will be distributed to the Board. If not, the pamphlet will be uploaded and available online.

- FDOT Requested Design Changes

Robert Powers stated that there should be a mechanism to force outside agencies that make design changes to City projects to pay for those requested changes. He requested that the City Attorney draft a resolution to this effect.

- Parks Department Representative at Board Meetings

The Board requested that the Parks Director or his designee be present at future Bond Oversight Board meetings to address questions from the Board. Ricardo Lambert inquired if there is a plan for acquisition of new park land.

- Quorum Requirements

Eileen Broton wanted to know when the issue regarding the Board's quorum requirements would be addressed.

Robin Jones-Jackson stated the best suggestion was to touch base with the individual that appointed each member and explain the Board's concern regarding the quorum requirements. Bring feedback to the audit subcommittee meeting to be considered at the next board meeting. Then an ordinance can be drafted to reflect what the Board and the elected officials have determined would best suit the Board. The ordinance would then go to the City Commission for two readings and that is generally the process.



DEPARTMENT OF CAPITAL IMPROVEMENTS
PROJECT OVERVIEW FORM

1. DATE: 3/23/10 DISTRICT: 2
 NAME OF PROJECT: PIER FIRE LINE REPAIRS AT MIAMARINA
 INITIATING DEPARTMENT/DIVISION: Public Facilities
 INITIATING CONTACT PERSON/CONTACT NUMBER: Stephen Bogner (305) 579-6920
 C.I.P. DEPARTMENT CONTACT: _____
 RESOLUTION NUMBER: _____ CIP/PROJECT NUMBER: B-39903

2. BUDGETARY INFORMATION: Are funds budgeted? YES NO If yes,
 TOTAL DOLLAR AMOUNT: \$250,000
 SOURCE OF FUNDS: Waterfront Improvements Citywide
 ACCOUNT CODE(S): _____
 If grant funded, is there a City match requirement? YES NO
 AMOUNT: _____ EXPIRATION DATE: _____
 Are matching funds budgeted? YES NO Account Code(s): _____
 Estimated Operations and Maintenance Budget _____

3. SCOPE OF PROJECT:
 Individuals / Departments who provided input: _____
 DESCRIPTION OF PROJECT: Remove and replace 1,200 linear ft. of rusted and corroded iron pipe, connections, fittings and support brackets for Piers A, B and C.
 LOCATION: 401 Biscayne Boulevard
 ADA Compliant? YES NO N/A

Approved by Audit Committee? YES NO N/A DATE APPROVED: 3/17/10
 Approved by Bond Oversight Board? YES NO N/A DATE APPROVED: 3/23/10
 Approved by Commission? YES NO N/A DATE APPROVED: _____
 Revision(s) to Original Scope? YES NO (If YES see Item 5 below)
 Time Approval 6 months 12 months Date for next Oversight Board Update: _____

4. CONCEPTUAL COST ESTIMATE BREAKDOWN
 Has a conceptual cost estimate been developed based upon the initial established scope? YES NO If yes,
 DESIGN COST: _____
 CONSTRUCTION COST: _____
 Is conceptual estimate within project budget? YES NO
 If not, have additional funds been identified? YES NO
 Source(s) of additional funds: _____

Approved by Commission? YES NO N/A DATE APPROVED: _____
 Approved by Bond Oversight Board? YES NO N/A DATE APPROVED: _____

5. REVISIONS TO ORIGINAL SCOPE
 Individuals / Departments who provided input: _____
 Justifications for change: _____
 Description of change: _____

Fiscal Impact YES NO HOW MUCH? _____
 Have additional funds been identified? YES NO
 Source(s) of additional funds: _____

Time impact _____
 Approved by Commission? YES NO N/A DATE APPROVED: _____
 Approved by Bond Oversight Board? YES NO N/A DATE APPROVED: _____

6. COMMENTS: Audit Subcommittee members approved \$250,000 out of \$300,000 of HD Funds.

APPROVAL: *J. J. Javes*
 BOND OVERSIGHT BOARD

DATE: 3/23/10

Lopez, Marcia

From: Newhoff, Daniel
Sent: Wednesday, March 10, 2010 2:56 PM
To: Marcos, Glenn; Aluko, Ola O.
Cc: Bogner, Stephen; Free, Thelma; Perez, Danette; Smith, Yvette; Lopez, Marcia
Subject: Pier Fire Line Repairs at Miamarina
Attachments: SCE8BA.PDF; JG 102.jpg; Miamarina Pier Fire Line Repairs.ppt

Glenn / Ola,

We're having a problem at Miamarina where our fire line stand pipes have become deteriorated and are in need of replacement. A situation arose where galvanic action and rust have created leaks in several sections of the pipe. Between Piers A, B, and C, we have about 1200 linear ft of pipe (400 per pier) needing replacement. Pier A is in the worst shape, probably because of seawater swells splashing against the breakwater underneath, thus spraying the adjacent pipes. Also, the Fire Dept is anxious for us to move this project along. CIP has identified approximately \$300,000 of HD3 funds available for Waterfront Improvements Citywide. Upon BOB approval on 3/16, Project B-39903 would be set up accordingly in Oracle.

I'm unsure whether to request an estimated \$246,000 to the BOB Board (per quote) or the full \$300,000 Yvette has located for us (with/ CIP fees?).

Please let me know your thoughts concerning whether this should be a straight line Purchasing bid vs. a CIP project..

Thanks again

Daniel Newhoff
Asst. Director
Dept. of Public Facilities
305 -416-5962
Dnewhoff@miamigov.com

LICENSED AND INSURED CC6469 / CFC057007

Bill To: Miamarina at Bayside Attn: Pablo 401 Biscayne Blvd Miami, FL 33132 Work: (305) 579-6955 Fax: (305) 579-6957	Work Location: Primary Miamarina at Bayside 401 Biscayne Blvd Miami, FL 33132 Work: (305) 579-6955 Fax: (305) 579-6957
---	---

Expected Service Date: T.B.D. NEW WATER PIPES FOR ALL 3 PIERS

Expected Service Time:

Date	Product/Service	Description	Price	Qty	Tax	Amount
2/16/2010	120 - REGULAR ESTIMATE	ESTIMATE FOR FUTURE WORK	\$245,755.00		\$0.00	\$245,755.00

Subtotal: \$245,755.00
 Tax: \$0.00
Total: \$245,755.00

Notes

WE HEREBY SUBMIT OUR ESTIMATE FOR PLUMBING WORK AS FOLLOWS:

BUDGET AS FOLLOWS: We will will replace the entire fire main from each main valve at bulkhead all the way out each pier to the last fire cabinet. We will replace piping for A, B & C Piers. We will install new Schedule 80 p.v.c. pipe and fittings. We will redo core through sea wall and cut concrete and patch as needed. We will redo all bad brackets with new stainless steel supports and hardware. We will reconnect to all existing fire cabinets.

Existing brackets will break soon and cause a major problem.

Permit fee to be waived by City Of Miami.

WE PROPOSE TO FURNISH MATERIALS AND LABOR IN ACCORDANCE WITH THE ABOVE SPECIFICATIONS. PAYMENTS ON THIS PROPOSAL ARE TO BE MADE AS FOLLOWS: Payment to be made in phases as job progresses.

ALL PRICES ON THIS PROPOSAL ARE "NET" PRICES. NO OTHER DISCOUNTS OR PROMOTIONS OF ANY TYPE WILL BE ALLOWED ON THIS PROPOSAL.

TERMS OF PROPOSAL:

=====
 All material is guaranteed to be as specified & all work will be completed in a professional manner according to standard practices. Any alteration or deviation from above specifications involving extra costs will be executed only if requested in writing and will be subject to additional charges over and above the original estimate. All agreements are contingent upon strikes, accidents or delays not under our control. Property owner agrees to carry all necessary insurance for the property. Our workers are covered by Workers Compensation. QUOTATION IS VALID FOR 30 DAYS!

ACCEPTANCE OF PROPOSAL:

=====
 The above prices specifications and conditions are satisfactory and are hereby accepted. You are authorized to do the work as specified and payments will be made as specified above. This proposal is subject to change if not accepted within 30 days from the date it was printed. (SHOWN ABOVE)

SIGNATURE: _____
 FOR BAY PLUMBING

OWNERS SIGNATURE: _____

OWNERS SIGNATURE: _____

Pier Fire Line Repairs at MiaMarina





DEPARTMENT OF CAPITAL IMPROVEMENTS

PROJECT OVERVIEW FORM

1. DATE: 3/23/10 DISTRICT: Citywide
NAME OF PROJECT: PIERCE ARROW XT SPECIAL RESPONSE VEHICLE
INITIATING DEPARTMENT/DIVISION: Fire Rescue
INITIATING CONTACT PERSON/CONTACT NUMBER: Veldora Arthur (305) 416-1024
C.I.P. DEPARTMENT CONTACT:
RESOLUTION NUMBER: CIP/PROJECT NUMBER:

2. BUDGETARY INFORMATION: Are funds budgeted? [X] YES [] NO If yes,
TOTAL DOLLAR AMOUNT: \$639,825
SOURCE OF FUNDS: Fire Rescue HD Preparedness Initiative
ACCOUNT CODE(S): 313305
If grant funded, is there a City match requirement? [] YES [] NO
AMOUNT: EXPIRATION DATE:
Are matching funds budgeted? [] YES [] NO Account Code(s):
Estimated Operations and Maintenance Budget

3. SCOPE OF PROJECT:
Individuals / Departments who provided input:
DESCRIPTION OF PROJECT: Purchase of one (1) Pierce Arrow XT Special Response Vehicle.
LOCATION: Citywide
ADA Compliant? [X] YES [] NO [X] N/A

Approved by Audit Committee? [X] YES [] NO [] N/A DATE APPROVED: 3/17/10
Approved by Bond Oversight Board? [] YES [] NO [] N/A DATE APPROVED: 3/23/10
Approved by Commission? [] YES [] NO [] N/A DATE APPROVED:
Revision(s) to Original Scope? [] YES [] NO (If YES see Item 5 below)
Time Approval [] 6 months [] 12 months Date for next Oversight Board Update:

4. CONCEPTUAL COST ESTIMATE BREAKDOWN
Has a conceptual cost estimate been developed based upon the initial established scope? [] YES [] NO If yes,
DESIGN COST:
CONSTRUCTION COST:
Is conceptual estimate within project budget? [] YES [] NO
If not, have additional funds been identified? [] YES [] NO
Source(s) of additional funds:

Approved by Commission? [] YES [] NO [] N/A DATE APPROVED:
Approved by Bond Oversight Board? [] YES [] NO [] N/A DATE APPROVED:

5. REVISIONS TO ORIGINAL SCOPE
Individuals / Departments who provided input:
Justifications for change:
Description of change:

Fiscal Impact [] YES [] NO HOW MUCH?
Have additional funds been identified? [] YES [] NO
Source(s) of additional funds:
Time impact
Approved by Commission? [] YES [] NO [] N/A DATE APPROVED:
Approved by Bond Oversight Board? [] YES [] NO [] N/A DATE APPROVED:

6. COMMENTS: Audit Subcommittee members requested for a follow-up with Glenn and/or Diana regarding a discount of \$22,450 if payment is made within 15 days of issuance of a P.O.

APPROVAL: [Signature]
BOND OVERSIGHT BOARD

DATE: 3/23/10

City of Miami



PEDRO C. HERNANDEZ, P.E.
City Manager

November 10, 2009

Chief J. R. Fernandez
Chief of Support Services
City of Miami Fire-Rescue
1151 NW 7 St.
Miami, FL 33136

Chief Fernandez,

Attached is a quote from Mike Schneider from Ten-8 Fire Equipment for the purchase of one (1) Pierce Arrow XT Special Response Vehicle from the Florida Sheriff's bid 08-08-0909 which expires December 31, 2009. The City Commission has approved resolution 05-520 to purchase of vehicles from the Florida Sheriff's bid.

Unit price from Florida Sheriff's Bid with Miami options	\$669,825.00
Pierce Factory Discount	\$- 30,000.00
Total Vehicle Cost	\$639,825.00

An optional 100% pre payment discount of \$22,450 is available if payment is received within 15 days of issuance of a Purchase Order. A performance bond calculated at 6% per \$1,000 is available at a cost of \$3,704 based on the 100% pre payment discount price of \$617,375.00.

The price includes two trips to the Pierce manufacturing site for three (3) personnel to the pre-construction meeting and three (3) personnel to the final inspection.

Sincerely,

A handwritten signature in black ink that reads "T. P. Klimoski Jr., Capt.".

Thomas P. Klimoski Jr., Capt.
Apparatus and Equipment Officer

PROPOSAL FOR FURNISHING FIRE APPARATUS

Oct 15, 2009

City of Miami
 1151 NW 7th Street
 Miami, FL 33136

The undersigned is prepared to manufacture for you, upon an order being placed by you, for final acceptance by Pierce Manufacturing, Inc., at its home office in Appleton, Wisconsin, the apparatus and equipment herein named and for the following prices:

One Pierce Custom HDRP Special Response Vehicle	\$ 669,825.00
Purchase thru Florida Sheriff's Association Bid 08-08-0909	
Spec. 15, Level 11	
Pricing Contingent on Available 2009 Engines, and 2009 pricing	
Pricing Includes Required Equipment Quote SVQ11908	
<u>Optional Pre payment discounts</u>	
Chassis of \$292,614.00 will offer a discount of 12,769.00	
100% pre Payment of \$617,375.00 will include 22,450 discount	
Pre Pay Due 15 Days From Purchase Order	
<u>Optional Performance Bond, 6.00 per 1,000 = \$3704.00 on 100%</u>	
Pierce Factory Customer Discount -30,000.00	-30,000.00
	Total \$ 639,825.00

Said apparatus and equipment are to be built and shipped in accordance with the specifications hereto attached, delays due to strikes, war, or intentional conflict, failures to obtain chassis, materials, or other causes beyond our control not preventing, within about 180-210 working days after receipt of this order and the acceptance thereof at our office at Appleton, Wisconsin, and to be delivered to you at Miami, FL 33136

The specifications herein contained shall form a part of the final contract, and are subject to changes desired by the purchaser, provided such alterations are interlined prior to the acceptance by the company of the order to purchase, and provided such alterations do not materially affect the cost of the construction of the apparatus.

The proposal for fire apparatus conforms with all Federal Department of Transportation (DOT) rules and regulations in effect at the time of bid, and with all National Fire Protection Association (NFPA) Guidelines for Automotive Fire Apparatus as published at the time of bid, except as modified by customer specifications. Any increased costs incurred by first party because of future changes in or additions to said DOT or NFPA standards will be passed along to the customers as an addition to the price set forth above.

Unless accepted within 30 days from date, the right is reserved to withdraw this proposition.

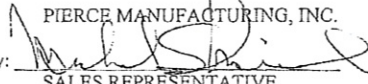
PIERCE MANUFACTURING, INC.
 By: 
 SALES REPRESENTATIVE





December 6, 2008

Florida Sheriff's Association
P.O. Box 12519
Tallahassee, FL 32317-2519n

Subject: Bid No. 08-08-0909

To all Participating Agencies;

We are pleased to submit this proposal for fire and rescue apparatus in conjunction with Pierce Manufacturing Inc. and Medtec Ambulance Corporation, subsidiaries of Oshkosh Truck Corporation. All insurance and bonds required will be issued by the selected manufacturer. As such, all purchase orders and payments are to be directly to the respective manufacturers in the care of Ten-8 Fire Equipment Inc. Ten-8 Fire Equipment Inc. will facilitate the transaction as a licensed Florida dealer. All payments shall be made through wire transfer or by check. Credit card payments will not be accepted.

Ten-8 Fire Equipment Inc. through our association with Pierce and Medtec is pleased to offer as part of FSA Sealed Bid No. 07-07-0828 financing and lease alternatives as provided by Oshkosh Capital.

Oshkosh Capital will provide financing and lease products for any of the Pierce or Medtec apparatus listed herein at a rate of 92.0% of the like term interest rate swap as published by the H.15 Federal Reserve Statistical Release. The rate shall be set seven days prior to the actual funding date of the lease. Terms of 3 to 10 years on Pierce products and terms of 3- 7 years on Medtec products are available. The effective rate of interest to be paid by customer shall be lower than stated herein if Pierce's or Medtec's exclusive prepay program is utilized. No down payment or other closing costs are required in this offering. First payment is due twelve months after contract signing. Offer is subject to credit approval by Oshkosh Capital. Rates are based upon tax exempt municipal leasing and purchasing agency must be qualified.

We greatly appreciate the opportunity to participate in the solicitation and look forward to serving all of the agencies accessing this contract.

Sincerely,

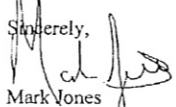

Mark Jones
Vice President

2904 59th Avenue Drive East • Bradenton, FL 34203
Phone: 800-228-8368 • Fax: 941-756-2598
www.ten8fire.com



DEPARTMENT OF CAPITAL IMPROVEMENTS
PROJECT OVERVIEW FORM

1. DATE: 3/23/10 DISTRICT: 2
 NAME OF PROJECT: BICENTENNIAL/MUSEUM PARK MOORING BOLLARDS
 INITIATING DEPARTMENT/DIVISION: Capital Improvements Program
 INITIATING CONTACT PERSON/CONTACT NUMBER: John De Pazos (305) 416-1094
 C.I.P. DEPARTMENT CONTACT: _____
 RESOLUTION NUMBER: _____ CIP/PROJECT NUMBER: B-30538A

2. BUDGETARY INFORMATION: Are funds budgeted? YES NO If yes,
 TOTAL DOLLAR AMOUNT: \$ 1,809,455 (\$953,750 is Homeland Defense)
 SOURCE OF FUNDS: HD Bicentennial Park Improvements, Bayfront Park Management Trust, Downtown Development Authority and FIND Waterways Assistance Program
 ACCOUNT CODE(S): 331418

If grant funded, is there a City match requirement? YES NO
 AMOUNT: _____ EXPIRATION DATE: _____
 Are matching funds budgeted? YES NO Account Code(s): _____
 Estimated Operations and Maintenance Budget _____

3. SCOPE OF PROJECT:
 Individuals / Departments who provided input: _____
 DESCRIPTION OF PROJECT: Install 16 large vessel mooring bollards along the north side of the FEC slip adjacent to Bicentennial Park to accommodate the mooring of visiting vessels including the Coast Guard Eagle.
 LOCATION: 1075 Biscayne Boulevard
 ADA Compliant? YES NO N/A

Approved by Audit Committee? YES NO N/A DATE APPROVED: 3/17/10
 Approved by Bond Oversight Board? YES NO N/A DATE APPROVED: 3/23/10
 Approved by Commission? YES NO N/A DATE APPROVED: _____
 Revision(s) to Original Scope? YES NO (If YES see Item 5 below)
 Time Approval 6 months 12 months Date for next Oversight Board Update: _____

4. CONCEPTUAL COST ESTIMATE BREAKDOWN
 Has a conceptual cost estimate been developed based upon the initial established scope? YES NO If yes,
 DESIGN COST: _____
 CONSTRUCTION COST: _____
 Is conceptual estimate within project budget? YES NO
 If not, have additional funds been identified? YES NO
 Source(s) of additional funds: _____

Approved by Commission? YES NO N/A DATE APPROVED: _____
 Approved by Bond Oversight Board? YES NO N/A DATE APPROVED: _____

5. REVISIONS TO ORIGINAL SCOPE
 Individuals / Departments who provided input: _____
 Justifications for change: _____
 Description of change: _____

Fiscal Impact YES NO HOW MUCH? _____
 Have additional funds been identified? YES NO
 Source(s) of additional funds: _____

Time impact _____
 Approved by Commission? YES NO N/A DATE APPROVED: _____
 Approved by Bond Oversight Board? YES NO N/A DATE APPROVED: _____

6. COMMENTS: Audit Subcommittee members inquired how much revenue does the City estimates it will receive if the project gets done. Chair requested for the PAF to be approved/signed by all parties.

APPROVAL: *John De Pazos*
 BOND OVERSIGHT BOARD

DATE: 3/23/10

Homeland Defense Neighborhood Improvement Bond Oversight Board

PROJECT ENGAGEMENT FORM

CAPITAL IMPROVEMENTS PROGRAM

PROJECT PHASE: Construction

PROJECT NAME:	Bicentennial/Museum Park Bollards
ADDRESS/LOCATION:	Bicentennial Park
PROJECT TEAM:	Vertical
CATEGORY:	Parks & Recreation
CLIENT DEPT:	Parks & Recreation
CLIENT CONTACT:	Ed Blanco
DESIGN MANAGER:	John De Pazos
CONSTR. MANAGER:	Nelson Cuadras
EST. DESIGN START:	N/A
EST. DESIGN END:	N/A

PROJECT NO.:	B - 30538A
DISTRICT:	2
PROJECT BUDGET:	\$ 1,809,455.00
PROJECT EST. DESIGN:	\$ 160,522.00
PROJECT EST. CONST.:	\$ 1,498,933.00

DATE PREPARED:	3/12/2010
VERSION:	Original
CONSTRUCTION COST Contracted:	\$ 1,332,022.00
CONSTRUCTION CONTINGENCY:	\$ 133,911.00
CIP - CONSTRUCTION MANAGEMENT:	\$ 75,000.00
GENERAL PRODUCTION PHASE CONTINGENCY:	N/A
MISC. SERVICES - GEOTECH TESTING:	N/A
MISC. SERVICES	\$ 33,000.00

AMOUNT HD FUNDS REQUESTED (Const. PHASE):	\$ 953,750.00
AMOUNT HD FUNDS PREVIOUSLY APPROVED:	\$ -
TOTAL AMOUNT:	\$ 953,750.00

PROCUREMENT TYPE:	Bid
EST. CONSTRUCTION START:	4/1/2010
EST. CONSTRUCTION END:	7/1/2010

PROJECT SCOPE: Install 16 large vessel mooring bollards along the north side of the FEC slip adjacent to Bicentennial Park to accommodate the mooring of visiting vessels including the Coast Guard Eagle.

HD funds consist of \$703,750 from HD Series 1 interest; \$250,000 from HD Series 3 of which \$100,000 is D2 Quality of Life

PROJECT JUSTIFICATION: To Initiate Construction

CITY OF MIAMI, FLORIDA
INTER-OFFICE MEMORANDUM

TO: Ola O Aluko, Director
Capital Improvements

DATE: March 9, 2010 FILE: **B-30538A**

SUBJECT: Project Funding
Bicentennial / Museum Park
Mooring Bollards

FROM: John De Pazos 
Capital Improvements

REFERENCES:

ENCLOSURES:

The above named project requires the following:

Description:

This Project Activation Form is to activate funding for the Bicentennial / Museum Park Mooring Bollards project adjacent to Museum Park.

Justification:

This project is a District Priority.

Funding:

Funding is available from:
Homeland Defense Series 1 Interest
Homeland Defense Series 3
Bayfront Park Management Trust
Downtown Development Agency
FIND Waterways Assistance Program

JDP

cc: Gary Fabrikant, Assistant Director Capital Improvements
File



PROJECT ANALYSIS FORM

Capital Improvements & Transportation

CIP
NON-CIP

Date Prepared:	22-Mar-2010
VERSION	ORIGINAL

PROGRAM 331-Parks and Recreation AREA 2-Recreation & Culture

PROJECT NAME: Bicentennial / Museum Park Mooring Bollards		PROJECT NO: B-30538A
ADDRESS / LOCATION: Bicentennial Park		DISTRICT: 2
PROJECT TEAM: Vertical		PROJECT CONTRACTED COST: \$ 105,185.97
CATEGORY: Parks and Recreation		CURRENT PROJECT EST. COST: \$ 1,809,455.00
CLIENT DEPT: 58-P&R-Parks and Recreation		CURRENT FUNDS: \$ 1,809,455.00
CLIENT CONTACT: Ed Blanco	TEL.: (305) 416-1253	FUTURE FUNDS:
DESIGN MANAGER: John DePazos (CIP)	TEL.: 305-416-1094	FUND SHORTFALL:
CONSTR. MANAGER: Carlos Vasquez (CIP)	TEL.: 305-416-1206	PROCUREMENT: Conventional
EST. DESIGN START: 04/01/09	EST. BID ADV.:	EST. CONSTRUCTION START: 09/01/09
EST. DESIGN END: 07/01/09	EST. AWARD DATE:	EST. CONSTRUCTION END: 10/01/10

PRODUCTION PHASE (3-DES)		CODE	% of Const	Pre-Design Est. Design	% of Const	Current Design Estimate	% of Const	Anticipated Design	P.O. Design
Consultant: 0000 To be Assigned									
1	Outside Consultant - Prime Basic Design Fee	1.01	6.8%	\$ 95,740	6.2%	\$ 93,000	5.7%	\$ 84,900	\$ 84,900
2	CIP - Production Management	1.04	3.4%	\$ 47,960	5.0%	\$ 74,500	5.0%	\$ 75,000	\$ 19,458
3	Advertising	1.01					0.04%	\$ 622	\$ 622
4									
PRODUCTION TOTALS				Estimated \$ 143,700		Estimated \$ 167,500		Anticipated \$ 160,522	Contracted \$ 104,980
CONST. PHASE (4-CON)		CODE	Pre-Design Estimated Construction by PM	Current Construction Estimate	Anticipated Construction by CM	P.O. Construction (Formal Bid, Informal Bid or JOC Method)			
Contractor: 0000 To be Assigned									
1	Construction Cost (Prime Contractor)	2.00	100% \$ 1,412,650	100% \$ 1,357,231	100% \$ 1,332,022				
2	Const. Contingency Allowance	2.00		10% \$ 135,724	10% \$ 133,911				
3	Misc. Construction Services	2.00			2% \$ 33,000				
4									
CONSTRUCTION TOTALS				Estimated \$ 1,412,650	Estimated \$ 1,492,955	Anticipated \$ 1,498,933	Contracted		
CONST. ADMIN. (8-CEO)		CODE	Pre-Design Est. CEO	Current Construction Administration Estimate	Anticipated CEO	P.O. CEO			
1 Const. Mgmt by CIP Const. Mgr		3.04	5.0% \$ 70,633	5.0% \$ 74,500	5.0% \$ 75,000	\$ 206			
2 Construction Engineering Observation by CIP Inspector		3.02							
3 JOC Admin.-The Gordian Group		3.03	1.9% \$ 26,250						
4									
CONSTRUCTION ADMINISTRATION TOTALS				Estimated \$ 96,883	Estimated \$ 74,500	Anticipated \$ 75,000	Contracted \$ 206		
ADMIN. EXPENSES (6-ADM)		CODE	Pre-Design ADMIN	Current Administrative Expenses Estimate	Anticipated ADMIN	P.O. ADMIN			
1 CIP Department (Mgmt./Budget/Procurement/Comm.)		4.00	0.5% \$ 7,063	5.0% \$ 74,500	5.0% \$ 75,000				
2									
ADMINISTRATIVE EXPENSES TOTALS				Estimated \$ 7,063	Estimated \$ 74,500	Anticipated \$ 75,000	Contracted		
ADDITIONAL PROJECT TASKS		CODE	Pre-Design Tasks	Current Additional Tasks Estimate	Anticipated Tasks	P.O. TASKS			
1									
ADDITIONAL PROJECT TASKS TOTALS				Estimated	Estimated	Anticipated	Contracted		
B-30538A PROJECT GRAND TOTAL				Pre-Design \$ 1,660,296	Estimated \$ 1,809,455	Anticipated \$ 1,809,455	Contracted \$ 105,186		

PROJECT SCOPE	Design and install ship bollards for Bicentennial Park on the north side of FEC slip					
	Operating Cost Associated with Project:					
	YEAR 1	YEAR 2	YEAR 3	YEAR 4	YEAR 5	

Notes

FUND SOURCES	AWARD NAME AND NUMBER		AVAILABLE	FUTURE
	1584	385200-3 2002 Homeland Defense Bonds (Series 3)	331418 Bicentennial Park Improvements	\$ 250,000
1457	385200-8 2002 Homeland Defense Series 1 Interest Post 09-30-06	331418 Bicentennial Park Improvements	\$ 703,750	
	888965 Bayfront Park Management Trust	331418 Bicentennial Park Improvements	\$ 150,000	
	888957 Downtown Development Agency	331418 Bicentennial Park Improvements	\$ 150,000	
1559	888920 FIND Waterways Assistance Program FY07 and Future	331418 Bicentennial Park Improvements	\$ 555,705	
B-30538A	FUND GRAND TOTAL		ACTUAL \$ 1,809,455	PROJECTED

VALIDATION	Initiated by:	John DePazos	Signature	Date:	3/22/10
		Project Manager: Capital Improvements			
	Approved by:	N/A	Signature	Date:	
		Team Leader: Capital Improvements			
	Accepted by:	Gary Fabrikant	Signature	Date:	3/23/10
		Assistant Director: Capital Improvements			
Verified by:	Edwige De Crumpe	Signature	Date:	3/22/2010	
	Program Controls Staff				
Reviewed by:	Yvette Smith	Signature	Date:	3/23/10	
	Administrator: Budget				
Authorized by:	Ola Aluko	Signature	Date:	3/22/10	
	Director: Capital Improvements				
Authorized by:	Ernest Burkeen	Signature	Date:	3/22/10	
	Director: Parks & Recreation				
	ORIGINAL TO: Melanie Whitaker / Capital Improvements 8th Floor			Initials	

Notes

Receipt of PAF by Danette Perez - CIP Public Relations Coordinator

Project MUST be Presented to the Bond Oversight Board

3/23/10 Date Received / Signature or Initials

Executed PAF MUST be electronically distributed to the following individuals:
 Director of the Client Department, Yvette Smith, Edwige De Crumpe, Senior Project Manager and Project Manager.

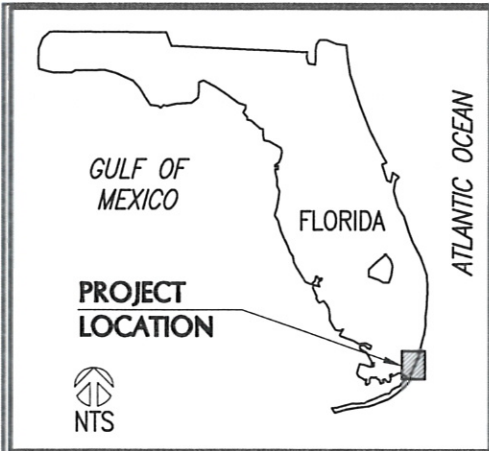

Sheet List Table	
Sheet Number	Sheet Title
1	COVER
2	EXISTING CONDITIONS
3	PROPOSED SITE PLAN
4	PROPOSED MARINE WORKS PLAN
5	MOORING STRUCTURES
6	TURBIDITY CURTAIN
7	TURBIDITY CURTAIN DETAILS
8	GENERAL NOTES

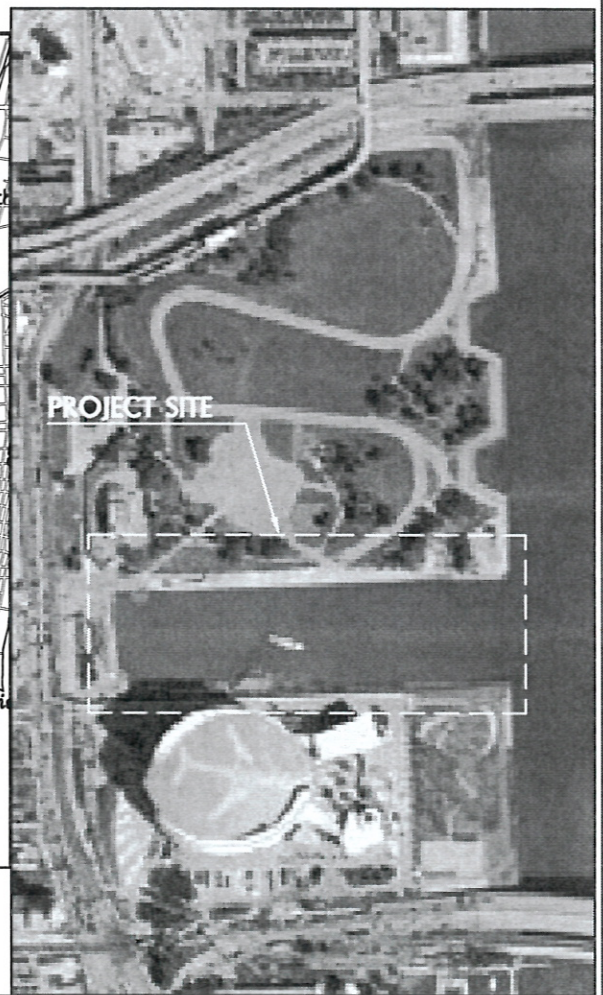
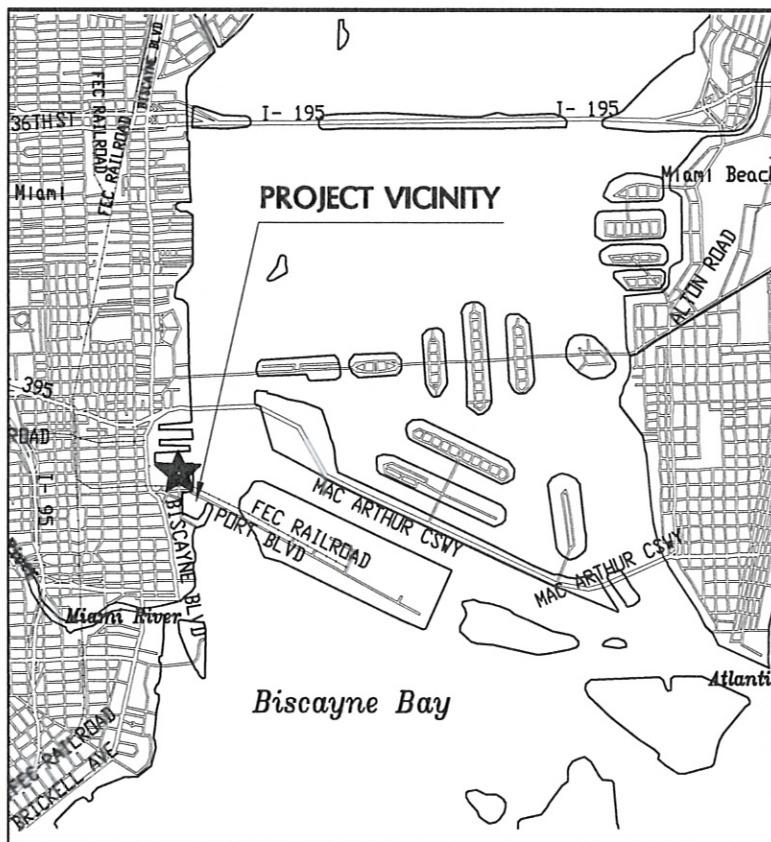

F:\Project\225903\Permit_Sketches\225903_COVER.dwg

		APP. NO:		CLIENT:	
		PROJECT NO:	225903	CITY OF MIAMI CAPITAL IMPROVEMENTS	
		DATUM:	NGVD	444 S.W. 2nd Ave., 8th FLOOR	
		DRAWN BY:	SV	MIAMI, FLORIDA 33130	
03/05/09	PERMIT SET	CHECKED BY:	JMB	LARGE VESSEL MOORING FACILITY	
DATE:	DESCRIPTION:	SUBMITTED BY:		MUSEUM PARK	
		COASTAL SYSTEMS INTERNATIONAL, INC. 464 South Dixie Highway, Coral Gables, Florida 33146 Tel: 305-661-3655 Fax: 305-661-1914 www.CoastalSystemsInt.com STATE OF FLORIDA EB #7087 Coastal, Environmental, Civil Engineering and Management		COVER	
T.K. BLANKENSHIP FL. REG. 55910				SHEET 1 OF 8	

F:\Project\225903\Permit_Sketches\225903_NEW_WORK.dwg

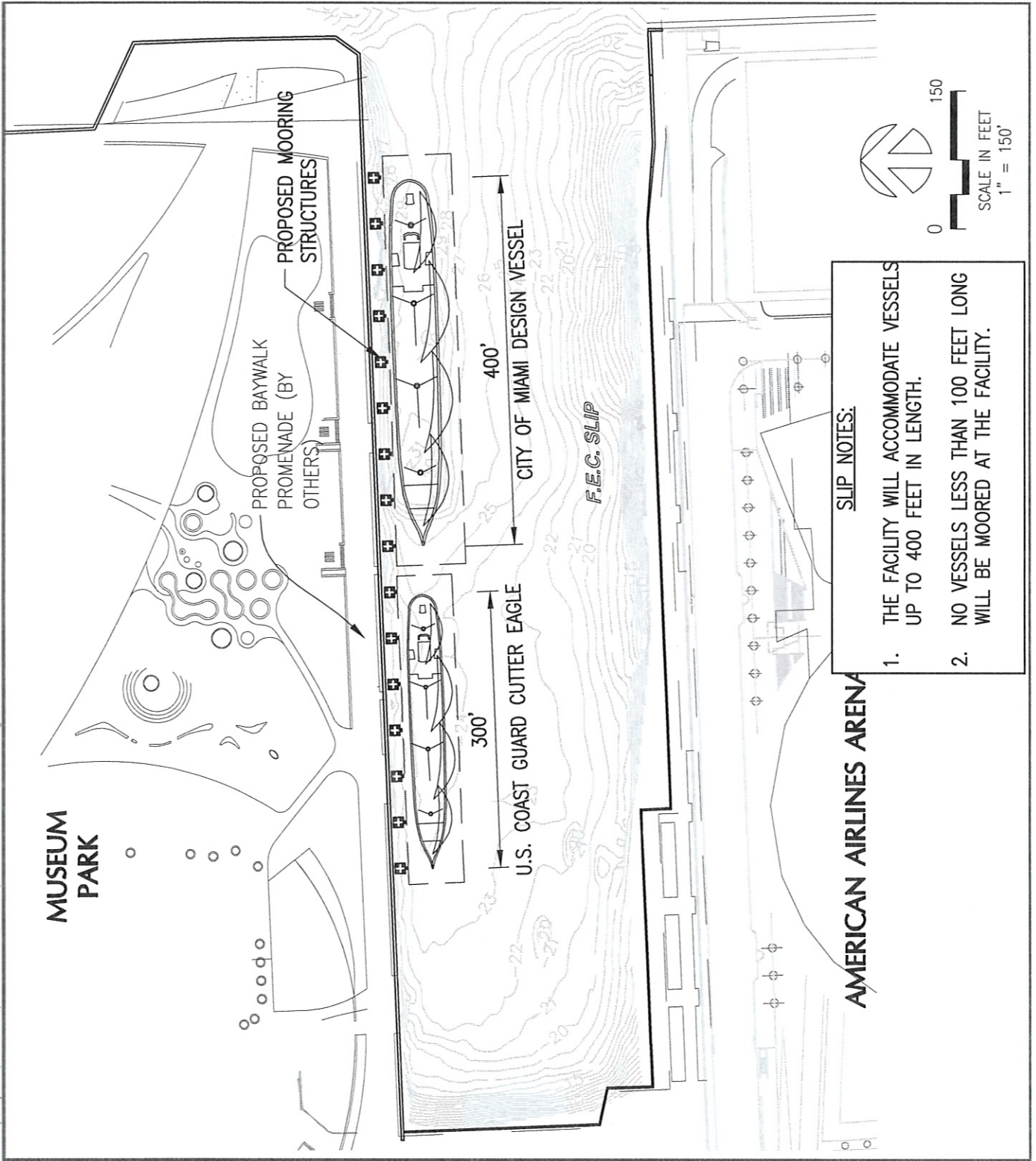

- SLIP NOTES:**
1. THE FACILITY WILL ACCOMMODATE VESSELS UP TO 400 FEET IN LENGTH.
 2. NO VESSELS LESS THAN 100 FEET LONG WILL BE MOORED AT THE FACILITY.

<p>T.K. BLANKENSHIP FL. REG. 55910</p>		<p>DATE: 03/05/09</p>		<p>DESCRIPTION: PERMIT SET</p>		<p>APP. NO:</p>		<p>PROJECT NO: 225903</p>		<p>CLIENT: CITY OF MIAMI CAPITAL IMPROVEMENTS 444 S.W. 2nd Ave., 8th FLOOR MIAMI, FLORIDA 33130</p>	
<p>COASTAL SYSTEMS INTERNATIONAL</p>		<p>DATE: 03/05/09</p>		<p>DESCRIPTION: PERMIT SET</p>		<p>DATUM: NGVD</p>		<p>DRAWN BY: SV</p>		<p>LARGE VESSEL MOORING FACILITY MUSEUM PARK</p>	
<p>COASTAL SYSTEMS INTERNATIONAL, INC. 464 South Dixie Highway, Coral Gables, Florida 33146 Tel: 305-661-3655 Fax: 305-661-1914 www.CoastalSystemsInt.com STATE OF FLORIDA EB #7087 Coastal, Environmental, Civil Engineering and Management</p>		<p>DATE: 03/05/09</p>		<p>DESCRIPTION: PERMIT SET</p>		<p>CHECKED BY: JMB</p>		<p>PROPOSED SITE PLAN</p>		<p>SHEET 3 OF 8</p>	

F:\Project\225903\Permit_Sketches\225903_NEW_WORK.dwg

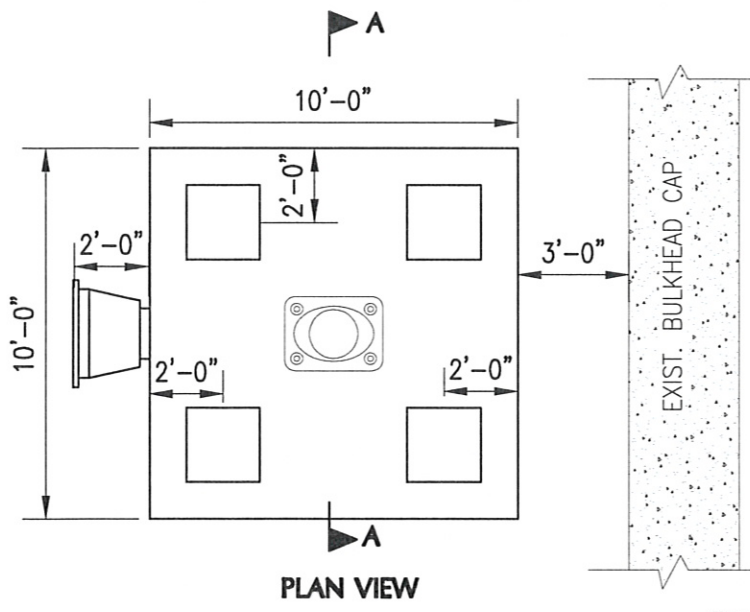

COORDINATE TABLE (CENTER OF STRUCTURE)		
PT.	EASTING (FT.)	NORTHING (FT.)
A	924096.1	527675.0
B	924046.1	527673.0
C	923996.1	527671.1
D	923946.2	527669.2
E	923896.2	527667.2
F	923846.2	527665.3
G	923796.3	527663.4
H	923746.3	527661.4
I	923696.4	527659.5
J	923646.4	527657.5
K	923596.4	527655.6
L	923546.5	527653.7
M	923496.5	527651.7
N	923446.5	527649.8
O	923396.6	527647.9
P	923346.6	527645.9

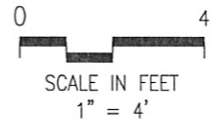
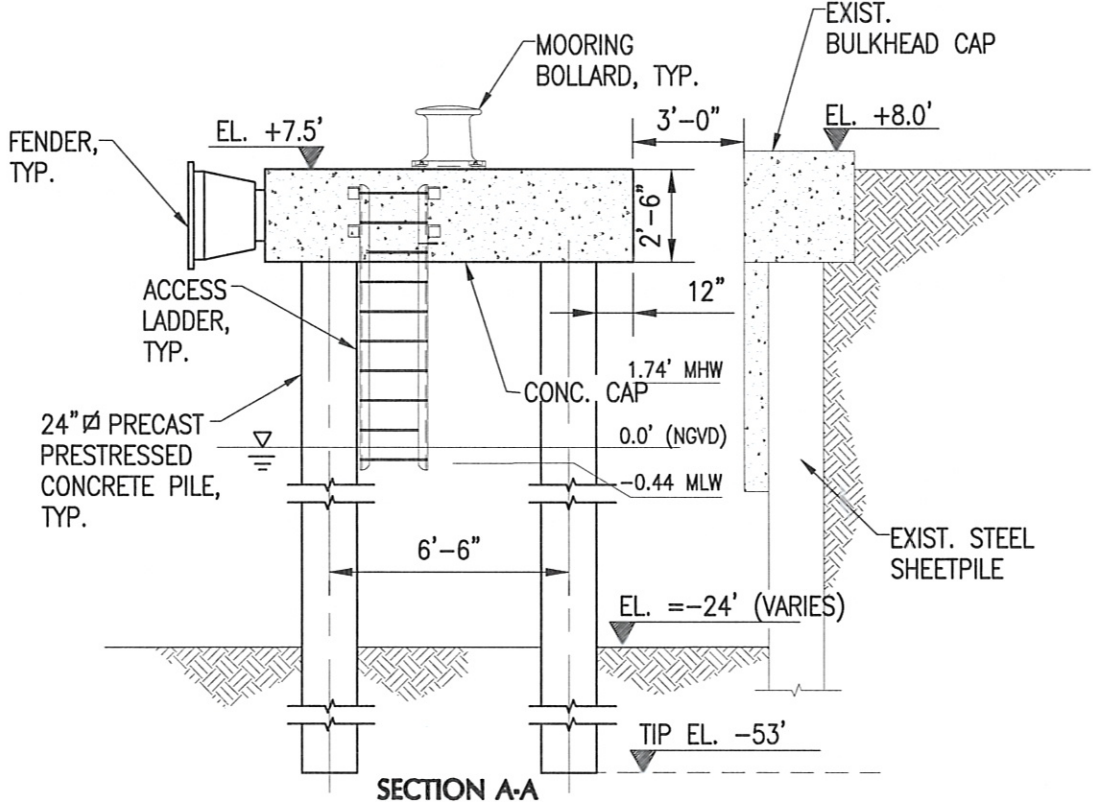

T.K. BLANKENSHIP FL. REG. 55910		COASTAL SYSTEMS INTERNATIONAL COASTAL SYSTEMS INTERNATIONAL, INC. 464 South Dide Highway, Coral Gables, Florida 33146 Tel: 305-661-3655 Fax: 305-661-1914 www.CoastalSystemsInt.com STATE OF FLORIDA EB #7087 Coastal, Environmental, Civil Engineering and Management		APP. NO.: PROJECT NO.: 225903 DATUM: NGVD DRAWN BY: SV CHECKED BY: JMB	CLIENT: CITY OF MIAMI CAPITAL IMPROVEMENTS 444 S.W. 2nd Ave., 8th FLOOR MIAMI, FLORIDA 33130 LARGE VESSEL MOORING FACILITY MUSEUM PARK MOORING STRUCTURES
DATE: 03/05/09 DESCRIPTION: PERMIT SET	SUBMITTED BY:	SHEET 5 OF 8			



DEPARTMENT OF CAPITAL IMPROVEMENTS
PROJECT OVERVIEW FORM

1. DATE: 3/23/10 DISTRICT: 5
 NAME OF PROJECT: NEW GIBSON PARK – DESIGN SERVICES
 INITIATING DEPARTMENT/DIVISION: Capital Improvements Program
 INITIATING CONTACT PERSON/CONTACT NUMBER: Ola O. Aluko (305) 416-1280
 C.I.P. DEPARTMENT CONTACT: _____
 RESOLUTION NUMBER: _____ CIP/PROJECT NUMBER: B-30305B

2. BUDGETARY INFORMATION: Are funds budgeted? YES NO If yes,
 TOTAL DOLLAR AMOUNT: \$9,794,667 (\$841,280 is Homeland Defense)
 SOURCE OF FUNDS: HD Series 1 & 2 Interest, CRA, Transit-Half Cent Surtax and Sunshine State Loan
 ACCOUNT CODE(S): _____
 If grant funded, is there a City match requirement? YES NO
 AMOUNT: _____ EXPIRATION DATE: _____
 Are matching funds budgeted? YES NO Account Code(s): _____
 Estimated Operations and Maintenance Budget _____

3. SCOPE OF PROJECT:
 Individuals / Departments who provided input: _____
 DESCRIPTION OF PROJECT: Demolition of existing park facilities including recreation building, playcourts, pool and utility building. Provide new sports field with artificial turf, 1,000 seat covered bleachers and press box. Convert existing Library to new classrooms and community meeting space. Build new Aquatic Center with new pool, restrooms, showers, lockers and new pump building; a new Recreation Building with administrative and fitness spaces; a new open park area with pavilions and play areas. The project is to meet LEED Silver standards.
 LOCATION: 411 NW 13 Street
 ADA Compliant? YES NO N/A

Approved by Audit Committee? YES NO N/A DATE APPROVED: _____
 Approved by Bond Oversight Board? YES NO N/A DATE APPROVED: 3/23/10
 Approved by Commission? YES NO N/A DATE APPROVED: 3/11/10
 Revision(s) to Original Scope? YES NO (If YES see Item 5 below)
 Time Approval 6 months 12 months Date for next Oversight Board Update: _____

4. CONCEPTUAL COST ESTIMATE BREAKDOWN
 Has a conceptual cost estimate been developed based upon the initial established scope? YES NO If yes,
 DESIGN COST: _____
 CONSTRUCTION COST: _____
 Is conceptual estimate within project budget? YES NO
 If not, have additional funds been identified? YES NO
 Source(s) of additional funds: _____
 Approved by Commission? YES NO N/A DATE APPROVED: _____
 Approved by Bond Oversight Board? YES NO N/A DATE APPROVED: _____

5. REVISIONS TO ORIGINAL SCOPE
 Individuals / Departments who provided input: _____
 Justifications for change: _____
 Description of change: _____
 Fiscal Impact YES NO HOW MUCH? _____
 Have additional funds been identified? YES NO
 Source(s) of additional funds: _____
 Time impact _____
 Approved by Commission? YES NO N/A DATE APPROVED: _____
 Approved by Bond Oversight Board? YES NO N/A DATE APPROVED: _____

6. COMMENTS: _____

 APPROVAL: _____ DATE: 3/23/10
 BOND OVERSIGHT BOARD



AGENDA ITEM SUMMARY FORM

FILE ID: 09-01457

Law Department
Matter ID No.
09-4213

Date: 2/26/10

Requesting Department: CIP

Commission Meeting Date: 3/11/10

District(s) Impacted: 1 2 3 4 5

Type: Resolution Ordinance Emergency Ordinance Discussion Item Other _____

Subject: Resolution authorizing the City Manager to execute an Agreement with Recreational Design and Construction Inc., ("RDC") in the not to exceed amount of \$10,774,133.70, for Design Build Services for the Design and Construction of Gibson Park, B-30305B.

Purpose of Item:

To authorize the City Manager to execute an Agreement for the provision of Design Build Services with RDC for the Design and Construction of Gibson Park, B-30305B, in the final negotiated amount of \$9,794,667, plus a ten percent owner contingency amount of \$979,466.70, for a total not to exceed amount of \$10,774,133.70. Allocating funds from Award Nos.: 1394 (CRA Contribution: \$1,000,000) project # 92-689001; 1297 (Transit-Half Cent Surtax: \$1,000,000) project # 40-B30305C; 1496 (Sunshine State Loan #2: \$7,932,854) project # 40-B30305B; and 1457 (Homeland Defense 1 & 2 Interest: \$841,280) project # 40-B30305B.

Background Information:

Capital Improvements Program (CIP) issued Request for Proposals (RFP) No. 08-09-064 on July 27, 2009, to select a qualified firm to provide Design Build Services for the Gibson Park project. On September 18, 2009, two (2) submittals were received in response to the RFP, with both firms deemed to be responsive.

On October 7, 2009, the Evaluation Committee ("Committee") met to discuss the submittals and determine the ranking of the Proposers. The firms were also given the opportunity to answer a series of structured questions, which had been previously provided to them, and each were able to present their team's experience and capabilities in the allotted timeframe.

Continued...

Budget Impact Analysis

NO Is this item related to revenue?

YES Is this item an expenditure? If so, please identify funding source below.

General Account No: _____

Special Revenue Account No: _____

CIP Project No: CRA Project # 92-689001, CIP # B-30305B & B-30305C

YES Is this item funded by Homeland Defense/Neighborhood Improvement Bonds?

Start Up Capital Cost: _____

Maintenance Cost: _____

Total Fiscal Impact: \$10,774,133.70

Final Approvals
(SIGN AND DATE)

CIP N/A

If using or receiving capital funds

Grants N/A

Purchasing N/A

Chief [Signature]

Budget Mung Bunk + 2/26/10

Risk Management N/A

Dept. Director _____

City Manager [Signature]

All firms received the same six questions and were allotted 45 minute increments, consisting of a maximum of 30 minutes for oral presentations and 15 minutes of unstructured questions.

The RFP consisted of a technical proposal portion, a fee proposal portion and submitted forms featuring a series of bonus points for the usage of certified small business and local workforce sub-contractors, with the last two items submitted in a separate sealed envelope to be evaluated after the review and evaluation of the technical proposals. Upon the completed review, the Evaluation Committee met again on October 14, 2009, to determine the final ranking order and based on their proposal and interview session, RDC was determined by the Committee to be the top-ranked firm.

RDC submitted a price of \$11,300,000 for Phase 1 of the Project and \$3,300,000 for Phase 2 of the Project for a total cost of \$14,600,000. The Evaluations Committee subsequently recommended CIP to enter into negotiations with RDC, pursuant to a memo approved by the City Manager on November 24, 2009. Based on these negotiations and ongoing discussions with the CRA, we were able to fund additional components of the project, which resulted in CIP revising the phasing of the project. CIP was also able to negotiate a fee in the not to exceed amount of \$9,794,667, which results in a reduction of the cost for Phases 1A, 1B and 2A of the project in the amount of \$1,000,000. Should funding become allocated for Phase 2B of the project, approval will be sought from the City Commission.



City of Miami

Legislation

Resolution

City Hall
3500 Pan American
Drive
Miami, FL 33133
www.miamigov.com

File Number: 09-01457

Final Action Date:

A RESOLUTION OF THE MIAMI CITY COMMISSION, WITH ATTACHMENT(S), AUTHORIZING THE CITY MANAGER TO EXECUTE AN AGREEMENT, IN SUBSTANTIALLY THE ATTACHED FORM, WITH RECREATIONAL DESIGN AND CONSTRUCTION, INC., FOR THE PROVISION OF DESIGN BUILD SERVICES FOR THE DESIGN AND CONSTRUCTION OF THE GIBSON PARK PROJECT, B-30305B ("PROJECT"), FOR PHASES 1A, 1B, 2A OF THE PROJECT, IN THE FINAL NEGOTIATED AMOUNT OF \$9,794,667, PLUS A TEN (10)PERCENT OWNER CONTINGENCY AMOUNT OF \$979,446.70, FOR A TOTAL NOT TO EXCEED AMOUNT OF \$10,774,133.70; ALLOCATING FUNDS FROM CAPITAL PROJECT NOS. B-30305B, B-30305C, AND FROM THE COMMUNITY REDEVELOPMENT AGENCY PROJECT NO. 92-689001.

WHEREAS, the Capital Improvements Program ("CIP") issued a Request for Proposals ("RFP") No. 08-09-064 on July 27, 2009, to select a qualified firm to provide design build services for the design and construction of the Gibson Park Project, B-30305B ("Project"); and

WHEREAS, on September 18, 2009, two (2) submittals were received in response to the RFP, with both firms deemed to be responsive; and

WHEREAS, the Evaluation Committee ("Committee") convened on October 7, 2009, to discuss the submittals, determine the ranking of the proposers and allow the firms an opportunity to answer a series of structured questions, which had been previously provided to them, and each were able to present their team's experience and capabilities in the allotted timeframe; and

WHEREAS, all firms received the same six questions and were allotted 45 minute increments, consisting of a maximum of 30 minutes for oral presentations and 15 minutes of unstructured questions; and

WHEREAS, the RFP consisted of a technical proposal portion, a fee proposal portion and completed forms featuring a series of bonus points for the usage of certified small business and local workforce sub-contractors, with the last two items submitted in a separate sealed envelope to be evaluated after the review and evaluation of the technical proposals; and

WHEREAS, upon the completed review, the Committee met again on October 14, 2009, to determine the final ranking order and based on their proposal and interview session, Recreational Design and Construction, Inc., ("RDC") was determined by the Committee to be the top-ranked firm; and

WHEREAS, RDC submitted a price proposal of \$14,600,000; \$11,300,000 for Phase I of the Project and \$3,300,000, for Phase 2 of the Project; and

WHEREAS, the Committee's recommendation to enter into negotiations with RDC was approved by the City Manager on November 24, 2009, and

WHEREAS, based on these negotiations and ongoing discussions with the Community Redevelopment Agency ("CRA"), the Administration was able to fund additional components of the Project, which resulted in CIP revising the phasing of the Project; and

WHEREAS, CIP was also able to negotiate a fee in the not to exceed amount of \$9,794,667, which results in a reduction of the cost for Phases 1A, 1B and 2A of the Project in the amount of \$1,000,000; and

WHEREAS, pursuant to this Resolution, the City Manager is requesting authorization to execute an Agreement for the provision of design build services with RDC, in the final negotiated amount of \$9,794,667, for Phases 1A, 1B and 2A of the Project, plus a ten percent owner contingency amount of \$979,446.70, for a total not to exceed amount of \$10,774,133.70; and

WHEREAS, funding for said Phases is to be allocated from Capital Project Nos. B-30305B, B-30305C, and the CRA Project No. 92-689001; and

WHEREAS, should funding become allocated for Phase 2B of the Project, approval will be sought from the City Commission;

NOW, THEREFORE, BE IT RESOLVED BY THE COMMISSION OF THE CITY OF MIAMI, FLORIDA:

Section 1. The recitals and findings contained in the Preamble to this Resolution are adopted by reference and incorporated as if fully set forth in this Section.

Section 2. The City Manager is authorized {1} to execute the Agreement, in substantially the attached form, with RDC, for the provision of design build services for the design and construction of the Project, for Phases 1A, 1B, 2A of the Project, in the final negotiated amount of \$9,794,667, plus a ten (10) percent owner contingency amount of \$979,446.70, for a total not to exceed amount of \$10,774,133.70, with funds allocated from Capital Project Nos. B-30305B, B-30305C and the CRA Project No. 92-689001.

Section 3. This Resolution shall become effective immediately upon its adoption and signature of the Mayor.{2}

APPROVED AS TO FORM AND CORRECTNESS 

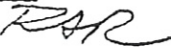

JULIE O. BRU
CITY ATTORNEY 

Footnotes:

{1} The herein authorization is further subject to compliance with all requirements that may be imposed by the City Attorney, including but not limited to those prescribed by applicable City Charter and Code provisions.

{2} If the Mayor does not sign this Resolution, it shall become effective at the end of ten calendar days from the date it was passed and adopted. If the Mayor vetoes this Resolution, it shall become effective immediately upon override of the veto by the City Commission.



DEPARTMENT OF CAPITAL IMPROVEMENTS
PROJECT OVERVIEW FORM

1. DATE: 3/17/10 DISTRICT: 2
 NAME OF PROJECT: LAND ACQUISITION - 1814 BRICKELL AVENUE
 INITIATING DEPARTMENT/DIVISION: Capital Improvements Program
 INITIATING CONTACT PERSON/CONTACT NUMBER: Ola Aluko (305) 416-1280
 C.I.P. DEPARTMENT CONTACT: _____
 RESOLUTION NUMBER: _____ CIP/PROJECT NUMBER: B-30685

2. BUDGETARY INFORMATION: Are funds budgeted? YES NO If yes,
 TOTAL DOLLAR AMOUNT: \$2,587,775 (\$500,000 is Homeland Defense D2 QOL)
 SOURCE OF FUNDS: District 2 Quality of Life, MDC Safe Neighborhood Parks Bond, Impact Fees and Sunshine State Loan
 ACCOUNT CODE(S): 311712

If grant funded, is there a City match requirement? YES NO
 AMOUNT: \$2,260,000 EXPIRATION DATE: _____
 Are matching funds budgeted? YES NO Account Code(s): _____
 Estimated Operations and Maintenance Budget _____

3. SCOPE OF PROJECT:
 Individuals / Departments who provided input: _____
 DESCRIPTION OF PROJECT: Land acquisition for green "park" space at 1814 Brickell Avenue.
 LOCATION: 1814 Brickell Avenue
 ADA Compliant? YES NO N/A

Approved by Audit Committee? YES NO N/A DATE APPROVED: 3/17/10
 Approved by Bond Oversight Board? YES NO N/A DATE APPROVED: 3/23/10
 Approved by Commission? YES NO N/A DATE APPROVED: 1/14/10
 Revision(s) to Original Scope? YES NO (If YES see Item 5 below)
 Time Approval 6 months 12 months Date for next Oversight Board Update: _____

4. CONCEPTUAL COST ESTIMATE BREAKDOWN
 Has a conceptual cost estimate been developed based upon the initial established scope? YES NO If yes,
 DESIGN COST: _____
 CONSTRUCTION COST: _____
 Is conceptual estimate within project budget? YES NO
 If not, have additional funds been identified? YES NO
 Source(s) of additional funds: _____

Approved by Commission? YES NO N/A DATE APPROVED: _____
 Approved by Bond Oversight Board? YES NO N/A DATE APPROVED: _____

5. REVISIONS TO ORIGINAL SCOPE
 Individuals / Departments who provided input: _____
 Justifications for change: _____
 Description of change: _____

Fiscal Impact YES NO HOW MUCH? _____
 Have additional funds been identified? YES NO
 Source(s) of additional funds: _____

Time impact _____
 Approved by Commission? YES NO N/A DATE APPROVED: _____
 Approved by Bond Oversight Board? YES NO N/A DATE APPROVED: _____

6. COMMENTS: _____

APPROVAL: *J. James* DATE: 3/23/10
 BOND OVERSIGHT BOARD



AGENDA ITEM SUMMARY FORM

RE.3

FILE ID: 10-00066

Date: 1/28

Requesting Department: Grants Admin

Commission Meeting Date: 1/28/2010

District Impacted: 2

Law Department
Matter ID No.

Type: Resolution Ordinance Emergency Ordinance Discussion Item

Other _____

Subject: Acceptance of Grant - Miami-Dade County Safe Neighborhood Parks Bond - 1814 Brickell
Purpose of Item:

It is recommended that the Miami City Commission adopt the attached Resolution, with attachments, authorizing the City Manager to accept a grant award from Miami-Dade County's Safe Neighborhood Parks Bond Program in the amount not to exceed \$327,775 for the acquisition of land located at 1814 Brickell Avenue; authorizing the allocation of the required match (non-general fund) not to exceed \$2,260,000 for Park Land Purchase at 1814 Brickell; authorizing the City Manager to execute the necessary documents in substantially the attached forms, for acceptance of grant award for fiscal year 2010, and submit to the terms and conditions of said grant agreements.

Background Information:

Due to the lack of park space in a high-density residential area, Miami-Dade County approved the use of grant funds to purchase park land at 1814 Brickell Avenue to increase the City of Miami's inventory of green spaces.

Budget Impact Analysis

NO Is this item related to revenue?

YES Is this item an expenditure? If so, please identify funding source below.

General Account No: _____

Special Revenue Account No: _____

CIP Project No: see attached B-30685

~~NO~~ YES Is this item funded by Homeland Defense/Neighborhood Improvement Bonds? No impact on C.F. n

Start Up Capital Cost: _____

Maintenance Cost: _____

Total Fiscal Impact: \$2,587,775

Final Approvals
(SIGN AND DATE) JS

CIP _____ Budget JS
If using or receiving capital funds
Grants JS Risk Management _____
Purchasing _____ Dept. Director _____
Chief _____ City Manager JS



City of Miami

Legislation

Resolution

City Hall
3500 Pan American
Drive
Miami, FL 33133
www.miamigov.com

File Number: 10-00066

Final Action Date:

A RESOLUTION OF THE MIAMI CITY COMMISSION AUTHORIZING THE CITY MANAGER TO ACCEPT A GRANT, IN THE AMOUNT OF \$327,775, FROM THE MIAMI-DADE COUNTY SAFE NEIGHBORHOOD PARKS BOND PROGRAM FOR THE ACQUISITION OF LAND LOCATED AT 1814 BRICKELL AVENUE, MIAMI, FLORIDA; AUTHORIZING THE ALLOCATION OF REQUIRED MATCHING FUNDS FROM NON-GENERAL FUND MONIES IN AN AMOUNT NOT TO EXCEED \$2,260,000 FOR THE PURCHASE OF 1814 BRICKELL AVENUE; FURTHER AUTHORIZING THE CITY MANAGER TO EXECUTE ALL NECESSARY DOCUMENTS TO IMPLEMENT THE ACCEPTANCE OF SAID GRANT AWARD, IN A FORM ACCEPTABLE TO THE CITY ATTORNEY.

WHEREAS, it is necessary to improve the quality of life, to benefit property values, to promote prevention of juvenile crime by providing positive recreation opportunities, and to improve the recreation facilities for youth, adults, and senior citizens in this community through the improvement of our parks and natural areas; and

WHEREAS, the City of Miami ("City") has been awarded a grant, in the amount of \$327,775 ("Grant"), from the Safe Neighborhood Parks Bond Program, for the funding of the acquisition of needed park space at 1814 Brickell Avenue; and

WHEREAS, the City recognizes the lack of green space in a high-density residential area and desires to better provide residents access to open space; and

WHEREAS, this project is congruent with the Miami 21 Parks and Public Space Master Plan; and

WHEREAS, match funding will be provided through non-general fund monies; and

WHEREAS, the City must execute a contract with Miami-Dade County to accept the Grant;

NOW, THEREFORE, BE IT RESOLVED BY THE COMMISSION OF THE CITY OF MIAMI, FLORIDA:

Section 1. The recitals and findings contained in the Preamble of this Resolution are adopted by reference and incorporated as if fully set forth in this Section.

Section 2. The City Manager is authorized{1} to accept a Grant, in the amount of \$327,775, from the Miami-Dade County Safe Neighborhood Parks Bond Program, to purchase the land located at 1814 Brickell Avenue, Miami, Florida for our residents.

Section 3. The allocation of required matching funds non-general fund monies in an amount not to exceed \$2,260,000 for the park land purchase at 1814 Brickell Avenue, Miami, Florida, is authorized.

Section 4. The City Manager is further authorized{1} to execute all necessary documents to implement the acceptance of the Grant, in a form acceptable to the City Attorney.

Section 5. This Resolution shall become effective immediately upon its adoption and signature of the Mayor.{2}

APPROVED AS TO FORM AND CORRECTNESS. 



JULIE O. BRU
CITY ATTORNEY

Footnotes:

{1} The herein authorization is further subject to compliance with all requirements that may be imposed by the City Attorney, including, but not limited to, those prescribed by applicable City Charter and Code provisions.

{2} If the Mayor does not sign this Resolution, it shall become effective at the end of ten calendar days from the date it was passed and adopted. If the Mayor vetoes this Resolution, it shall become effective immediately upon override of the veto by the City.

Title: Brickell Avenue Park Land Acquisition
New Project #: B-30685
Capital Fund: 35000

Award 1496, Sunshine State Loan #2, \$460,000

From: B-30153J in fund 34000, \$460,000

To: B-30685 in fund 35000, \$460,000

P = 40-B30685

A = 1496

T = 07

E = Land

O = 221100

\$460,000

Award 1584, Homeland Defense Bonds (District 2 – Quality of Life), \$500,000

From: B-39910 in fund 31000, \$500,000

To: B30685 in fund 35000, \$500,000

P = 40-B30685

A = 1584

T = 07

E = Land

O = 221100

\$500,000

Award 1422, Impact Fees, \$1,300,000

From: B-30635, \$916.76

From: B-30636, \$9,287

From: B-35853A, \$500,000

From: B-30638, \$100,000

From: B-35898, \$120,402.09

From: B-35906, \$92,886.90

From: B-75883, \$299,876.95

From: B-30639, \$99,607.49

From: B-30640, \$26,103.75

From: B-30642, \$50,000

From: B-35894A, \$919.06

All above in fund 35000
To: B-30685 in fund 35000, \$1,300,000

P = 40-B30685
A = 1422
T = 07
E = Land
O = 221100
\$1,300,000

SUB-TOTAL \$2,260,000

Safe Neighborhoods, \$327,775 (to be received)

TOTAL \$2,587,775

Attachment 4

2009 Safe Neighborhood Parks Discretionary Funding Recommendations

As Amended at the Recreation, Culture and Tourism Committee on November 10, 2009

Applicant/Grantee	Project Description	CD	Amount
City of North Miami	Pepper Park	1	\$161,370
City of Opa Locka	Sherbondy Park	1	293,400
City of Miami Gardens	Miami Gardens Community Center	2	500,000
City of Miami/Virginia Key Beach Park Trust	Virginia Key Beach Park	[[2]] >>7<<	49,473
Miami-Dade County Park	Little River Park	2	100,000
City of North Bay Village	West Drive Community Park	4	300,000
City of North Miami Beach	Miahoon Park	4	183,375
City of Sunny Isles Beach	Bella Vista Bay Park	4	200,000
City of Sunny Isles Beach	Golden Shores Park	4	*111,450
Town of Bay Harbor Islands	92 Street Park	4	53,000
Town of Bay Harbor Islands	98 Street Park	4	50,000
Village of Biscayne Park	Ed Burke Park	4	55,000
City of Miami Beach	Lummas Park	5	147,335
City of Miami Beach	Bandshell Park	5	150,000
City of Miami Springs	Community Center	6	41,833
>>Miami Dade County	AD Barnes Park	6	201,700<<
City of Coral Gables	Alhambra Park - Land Acquisition	7	220,050
City of Miami	1814 Brickell Avenue Park	7	[[483,375]] >>327,775<<
City of South Miami	Dison Park	7	50,000
City of South Miami	Murray Park Aquatic Center Pool	7	220,050
Miami-Dade County Park	Sunkist Park	7	175,000
Village of Pinecrest	Pinecrest Gardens	7	16,000
Village of Pinecrest	Pinecrest Gardens	7	30,000
Village of Pinecrest	Pinecrest Gardens	7	50,000
Village of Pinecrest	Pinecrest Gardens	7	*75,000
Village of Pinecrest	Pinecrest Gardens	7	20,000
City of Homestead	Harris Field Youth Sports Grounds and Skate Park	8	100,000
Town of Cutler Bay	Bel Air Park	8	179,400
Town of Cutler Bay	Saga Lake Park	8	113,200
Village of Palmetto Bay	Coral Reef Park	8	119,581
Village of Palmetto Bay	Thalatta Park	8	200,000
Miami-Dade County	Naranja Park	9	110,500
Miami-Dade County	Blue Lakes Park	10	140,600
Miami-Dade County	McMillan Park	10	191,600
Miami-Dade County	Ruben Daro Park	10	72,600
Memorial Cubano Inc./Miami-Dade County	Tamiami Park	11	200,000

*correct amount

48



City of Miami

Master Report

City Hall
3500 Pan American Drive
Miami, FL 33133
www.miamigov.com

Enactment Number: R-10-0004

File Number: 10-00034	File Type: Resolution	Status: Passed
Version: 2	Reference:	Controlling Body: Office of the City Clerk
File Name: Amendment-1814 Brickell		Introduced: 1/8/2010
Requester: Department of Public Facilities	Cost:	Final Action: 1/14/2010

Title: A RESOLUTION OF THE MIAMI CITY COMMISSION, WITH ATTACHMENT(S), RELATING TO THE PROPERTY LOCATED AT 1814 BRICKELL AVENUE, MIAMI, FLORIDA (THE "BRICKELL PROPERTY"), AUTHORIZING THE CITY MANAGER TO PURCHASE THE BRICKELL PROPERTY BY ASSUMING THE BUYER'S RIGHTS UNDER THE COMMERCIAL CONTRACT ATTACHED AS EXHIBIT "1", THEREBY SUBSTITUTING THE ATTACHED EXHIBIT "1" FOR THE COMMERCIAL CONTRACT THE CITY MANAGER WAS AUTHORIZED TO ASSUME BY RESOLUTION NO. 09-0504, ADOPTED OCTOBER 22, 2009; AUTHORIZING THE CITY MANAGER TO EXECUTE ALL AGREEMENTS RELATING THERETO, IN A FORM ACCEPTABLE TO THE CITY ATTORNEY; FURTHER AUTHORIZING THE PAYMENT OF ALL FUNDS NECESSARY TO CONSUMMATE THE PURCHASE, INCLUDING, BUT NOT LIMITED TO, THE PURCHASE PRICE, CLOSING COSTS, COSTS RELATING TO THE IMPLEMENTATION OF A COVENANT WITH THE FLORIDA DEPARTMENT OF STATE RELATIVE TO THE PRESERVATION OF UNMARKED HUMAN REMAINS ON THE BRICKELL PROPERTY, AND COSTS INCURRED AND TO BE INCURRED FOR PROFESSIONAL ARCHEOLOGICAL SERVICES PERFORMED AND TO BE PERFORMED ON THE PROPERTY, FROM NON-GENERAL FUNDS; FINDING AND DETERMINING THAT ONE OF THE CITYWIDE PARKING PROJECTS ON THE ORIGINAL PROJECT LISTS FOR THE CITY'S SUNSHINE STATE LOAN POOL FINANCINGS DOES NOT REQUIRE THOSE LOAN FUNDS DUE TO NEGOTIATIONS WHICH HAVE RESULTED IN THE LESSEE FINANCING THE BUILDING OF THAT PARKING FACILITY; FINDING AND DETERMINING THAT THE PROJECT LISTS FOR THE CITY'S SUNSHINE STATE LOAN POOL FINANCINGS FOR PARKS AND RECREATION PROJECTS SHALL BE AMENDED TO ADD A NEW CITY PARK TO BE LOCATED AT THE BRICKELL PROPERTY; AUTHORIZING AND DIRECTING THE CITY MANAGER TO EXECUTE, WITH APPROVAL OF THE CITY ATTORNEY, ALL NECESSARY DOCUMENTS IN ORDER TO AMEND THE PROJECT LISTS FOR THE CITY'S SUNSHINE STATE LOAN POOL LOAN AGREEMENTS.

Sponsors:

Notes:

Indexes:

Attachments: 10-00034 Legislation.pdf,10-00034-Exhibit-SUB.pdf,10-00034-Summary Form.pdf,

History of Legislative File

Version:	Acting Body:	Date:	Action:	Sent To:	Due Date:	Return Date:	Result:
1	Office of the City Attorney	1/13/2010	Reviewed and Approved				
2	Office of the City Attorney	1/14/2010	Reviewed and Approved				



City of Miami

Master Report

City Hall
3500 Pan American Drive
Miami, FL 33133
www.miamigov.com

Enactment Number: R-10-0004

2	City Commission	1/14/2010	ADOPTED WITH MODIFICATIONS	Pass
2	Office of the Mayor	1/15/2010	Signed by the Mayor	Office of the City Clerk
2	Office of the City Clerk	1/15/2010	Signed and Attested by City Clerk	



DEPARTMENT OF CAPITAL IMPROVEMENTS
PROJECT OVERVIEW FORM

UPDATE

1. DATE: 7/22/08 DISTRICT: Citywide
NAME OF PROJECT: Defense and Security Equipment Acquisition
INITIATING DEPARTMENT/DIVISION: Fire Rescue
INITIATING CONTACT PERSON/CONTACT NUMBER: Reginald Duren (305) 416-1610
C.I.P. DEPARTMENT CONTACT: Ola O. Aluko (305) 416-1280
RESOLUTION NUMBER: _____ CIP/PROJECT NUMBER: B-72813

2. BUDGETARY INFORMATION: Are funds budgeted? YES NO If yes,
TOTAL DOLLAR AMOUNT: \$899,000

SOURCE OF FUNDS: HDNI - Fire Rescue HD Preparedness Initiatives

If grant funded, is there a City match requirement? YES NO
AMOUNT: _____ EXPIRATION DATE: _____
Are matching funds budgeted? YES NO Account Code(s): _____
Estimated Operations and Maintenance Budget _____

3. SCOPE OF PROJECT:

Individuals / Departments who provided input: _____

DESCRIPTION OF PROJECT: Purchase of needed equipment to augment the resources available for the Dive Teams and new props associated with recruit firefighter training in order to maintain status of a State Certified Fire Training Facility (see attached equipment details).

ADA Compliant? YES NO N/A

Approved by Audit Committee? YES NO N/A DATE APPROVED: 7/15/08
Approved by Bond Oversight Board? YES NO N/A DATE APPROVED: 7/22/08
Approved by Commission? YES NO N/A DATE APPROVED: _____
Revisions to Original Scope? YES NO (If YES see Item 5 below)
Time Approval 6 months 12 months Date for next Oversight Board Update: _____

4. CONCEPTUAL COST ESTIMATE BREAKDOWN

Has a conceptual cost estimate been developed based upon the initial established scope? YES NO If yes,
DESIGN COST: _____
CONSTRUCTION COST: _____
Is conceptual estimate within project budget? YES NO
If not, have additional funds been identified? YES NO
Source(s) of additional funds: _____

Approved by Commission? YES NO N/A DATE APPROVED: _____
Approved by Bond Oversight Board? YES NO N/A DATE APPROVED: _____

5. REVISIONS TO ORIGINAL SCOPE

Individuals / Departments who provided input: _____

Justifications for change: _____

Description of change: _____

Fiscal Impact YES NO HOW MUCH? _____
Have additional funds been identified? YES NO
Source(s) of additional funds: _____

Time impact _____
Approved by Commission? YES NO N/A DATE APPROVED: _____
Approved by Bond Oversight Board? YES NO N/A DATE APPROVED: _____

6. COMMENTS:

APPROVAL: Reginald Duren DATE: 7/22/08
BOND OVERSIGHT BOARD

Enclosures: Back-Up Materials YES NO

Lopez, Marcia

From: Duren, Reginald
Sent: Thursday, July 10, 2008 4:08 PM
To: Lopez, Marcia
Cc: Perez, Danette; Jaramillo, Wendy
Subject: RE: Audit Subcommittee Meeting - July 2008
Attachments: Firefighters Standards and Training Rule 4A-37.pdf

Fire-Rescue is requesting to use Homeland Defense Bond (equipment) monies to provide for needed equipment to augment the resources available for our Dive Team. Additionally we are in need of new props associated with recruit firefighter training in order to maintain our status as a State Certified Fire Training Facility.

Dive Team

The following dive team items are requested as a result of the growth of our dive team from 49-63 divers.

- 15- ScubaPro MK2/R295 regulators \$147.00 each
- 15- ScubaPro MK25/S600 regulators \$355.00 each
- 15- ScubaPro Pressure/Depth Consoles w/compass \$160.00 each
- 10- 80 cu.ft. Aluminum tanks with valve \$160.00 each
- 10- 13cu.ft. Aluminum tanks with valve \$120.00 each
- 10- ScubaPro Classic Plus BC's with AIR 2 \$469.00 each

The following items will replace inventory in our present cache which is in excess of 10 years old.

- 10- AGA positive pressure full face mask w/ABV, hose and buddyphone \$1628.00

Total estimated cost is approximately \$34,000.00

Training Center

As a result of recent changes in requirements to maintain certification as a Fire Training Center (see requirements highlighted in the attached document "Rule 4A-37 Firefighters Standards and Training") the following props must be added to our current site.

- 1) Burn Tower and Search facility estimated cost \$750,000
- 2) LP Prop estimated cost \$20,000
- 3) Flammable Liquid Prop estimated cost \$15,000
- 4) Vehicle Fire Prop estimated cost \$80,000

Total estimated cost is approximately \$865,000.00

Total estimated cost of combined projects is \$899,000.00

Reginald K. Duren
Assistant Fire Chief
City of Miami Fire Rescue
Office: 305.416.1610
Fax: 305.400.5096

7/10/2008

2. Additional Funding for MiaMarina Emergency Repair Pier #5

Eileen Broton reported that the project is another revenue generator for the City. They're requesting \$97,000 of the original approved amount. The project will replace damaged pre-cast concrete stringers, replacement of wood decks with fiberglass and replacing utility services. The contract has already been awarded and construction is anticipated to begin next month with a targeted completion date in late September of '09.

- 3. Pierce Lance HAZMAT Vehicle for the Fire Department
- AND
- 4. Defense and Security Equipment Acquisition

Eileen Broton reported that the item was purchased and put into service in May 2008, and the Board requested information on how often it is used. Item 4, Defense and Security Equipment Acquisition, includes the scuba gear, which will be ordered in May of 2009, and also the training center. The standards for the training center are constantly changing, and the Fire Department is looking for the proper site and trying to see the latest requirements, so this may be on hold until possibly the last quarter of 2009, and we have asked the Fire Department to provide more information for us.

Joe Fernandez, assistant fire chief with the Department of Fire-Rescue, reported that he replaced Chief Duran on the project. The Pierce Lance truck was put in service in May 2008. It was purchased at budget, \$564,577. I do not have an exact number of alarm numbers to date, but I will tell you that this truck does not go out on every single call, kind of like you see the first line pumpers and aerial and rescue trucks. It's a specialized piece of equipment and it goes on certain types of calls when the dispatches come in, whether there's chemical situations, even structural events, and a variety of other specialized scenarios that we might have to respond to. As you know, the previous vehicle was beyond its service life, and the truck really has been a great asset, especially in the midst of everything that we find ourselves under these days, having a vehicle to move around the necessary equipment is very important. So we appreciate your support on it. And if you would like the number of calls that it has responded to since May 29, I can send that to the staff, and they can give it to you via e-mail. Regarding the scuba gear, the equipment here will allow for ten full sets of scuba gear, plus backup equipment to make sure we always have ten sets at the ready to do the services that we aim to do with this equipment. It will be, again, a citywide asset that will be located on the marine unit, and it's of great value, as I said, both for the citizens or visitors that may require services of this type, and for the firefighters themselves, to have the best gear possible to do the job they need to do. I did make a typo here. It was not the staff's fault. If you add the two items, it should come to 899. You see this says 32 as the estimated cost and it's actually 34. So if you add the 34 to the other total, you do get to the 899, but that was my error. This is currently slightly delayed due to a bid issue that the Purchasing Department wanted to do a split bid, I believe. I'm still transitioning with Chief Duran, but it's slightly delayed because of a process in the Purchasing Department, but we do expect to issue a purchase order by March '09 and delivery should be immediately after. This is all equipment, materials that are all readily available. Regarding the training tower, I gave you a sampling here of some photos from the various vendors that might be the actual suppliers of this equipment, and this type of training is not

only very valuable, but subsequent to a state rule, the training tower is now a requirement with specific standards for a certificated training facility. This is a new standard. We do not meet the standard, so this is required to remain as a certified training facility within the state. And these are two samples of more or less, what you would see the end product looking like, and then one of the props or simulation aids you'll see to the right is supposed to be a vehicle. It has the overall shape of a vehicle, but it is fed by gas. It's basically an appliance, and it allows the firefighters to practice with car fires and there's a few other simulation aids also so that they can train, and that's also required by that Rule 4837 that was imposed a year and a half or two years ago. Currently, this is proposed to be used at our training facility in Coconut Grove, where we do most of our other training. And there's an estimated 25 percent completion on the design phase. We're estimating somewhere around June 2010 to be complete on this project.

5. Armbrister Park Boundless Playground

Ed Blanco, Parks Department, reported that the project was completed. It was a \$250,000 project, and in addition to that, which you don't see in the pictures, we also added some swings on the other side of the play ground, at an additional \$50,000, swings with a rubber surface. So this whole project is about a \$300,000 project.

6. Athalie Range Park – Mini Stadium Complex

Eileen Broton reported that the project has been designed and is ready to go out for bid. The project is in the permitting stages. The Parks Department will make arrangements for the activities when the park must be closed for the construction.

Ed Blanco, Parks Department, reported that the permitting has been completed. The project is currently being bid out. The bid award date has been set for February 9, with an estimated construction to begin late March or early April.

7. Williams Park Recreation Building Improvements

Eileen Broton reported that this is not an improvement. It's going to be a new building, and there was a charrette held January 22 and it was highly announced to the public.

Ola Aluko, director, CIP, reported that there was a charrette last Thursday and the public received the plans very well, and we were given a vote of confidence to move forward. As of today, I believe we gave the architect an NTP to submit his proposal, and hopefully, within the next couple of days, we'll get a proposal for the design, and we'd like to move forward with the construction. This is another case where the original project was planned to be a renovation. We were going to add spaces to the park. The community made some comments to staff, to the administration and we listened to the community and we realized that with today's prices that we're getting in the construction industry, we can actually build a new building at the same cost that we were originally going to renovate and add spaces to the building. So we're actually doubling the size. The existing

Carmen Matos: If there is a hurricane or storm and trees are knocked down, is there a fund in place to replace them?

Larry Spring (Chief Financial Officer): Are there any other questions? I'd like to answer them all at the same time.

Charisse Grant: Does GSA have a regular schedule of maintenance for all of those properties?

Mr. Spring: Rolando, to answer your 50,000-foot question, the person or persons who are responsible for taking that high-level look and saying, okay, we've just invested \$155 million dollars, are we also ensuring in the operational budgets of each of the departments who are then responsible for maintaining those properties, that is something that's taken care of in our overall budget process. During that process, that information is provided by the directors to the Budget director in great detail. That information is then funneled up to myself, Roger Hernstadt, the other assistant city manager over budget, our City Manager, our Mayor and all our Commissioners. In individual meetings, we discuss all of those issues. They do come to the forefront, and then what is presented to our overall Commission includes those issues. We're moving staff around to be present. We're outreaching to different third parties to even help us program the facilities.

Vice Chairman Aedo: Is there, in the capital improvement world or in the budgeting world, a general rule of thumb when you're making a capital investment that "X" needs to be added into an upcoming budget cycle to account for the proper maintenance of that asset?

Mr. Spring: There are plenty of operational standards, if you will, that exist. Part of the requirements of the capital plan is that when we have a project coming up, the user department is supposed to submit a five-year or ten-year operating plan. So you'll have the capital piece and then you'll have this multiyear budget that shows some of the operational needs. Clearly, we're not going to allow for maintenance to suffer again. We're not going to go back through this cycle that we just found ourselves getting out of. However, we do have to balance all of our budgetary constraints. A lot of the maintenance is on-call. We have been in the mode of trying to develop a routine maintenance program in GSA, but we're going from zero to a hundred in a matter of a few years.

- Stephanie Grindell, Director of Public Works to discuss maintenance & operations

THIS ITEM WAS DEFERRED TO THE NEXT BOARD MEETING.

- Defense and Security Equipment Acquisition

<p>NAME OF PROJECT: <u>Defense and Security Equipment Acquisition</u> TOTAL DOLLAR AMOUNT: <u>\$899,000</u> SOURCE OF FUNDS: <u>HDNI - Fire Rescue HD Preparedness Initiatives</u> DESCRIPTION OF PROJECT: <u>Purchase of needed equipment to augment the resources available for the Dive Teams and new props associated with recruit firefighter training in order to maintain status of a State Certified Fire Training Facility (see attached equipment details).</u></p>

HD/NIB MOTION 08-21

A MOTION TO FUND THE DEFENSE AND SECURITY EQUIPMENT ACQUISITION.

MOVED: R. Aedo
SECONDED: C. Matos
ABSENT: M. Cruz, R. Lambert, G. Reshefsky, J. Reyes, J. Solares, H. Willis

Note for the Record: Motion passed by unanimous vote of all Board Members present.



DEPARTMENT OF CAPITAL IMPROVEMENTS
PROJECT OVERVIEW FORM

ADDITIONAL FUNDING

COMPLETED

1. DATE: 1/27/09 DISTRICT: 2
 NAME OF PROJECT: ADDITIONAL FUNDING FOR DINNER KEY MOORING FIELD
 INITIATING DEPARTMENT/DIVISION: Capital Improvements Program
 INITIATING CONTACT PERSON/CONTACT NUMBER: Carlos Vasquez (305) 416-1206
 C.I.P. DEPARTMENT CONTACT: _____
 RESOLUTION NUMBER: _____ CIP/PROJECT NUMBER: B-33511

2. BUDGETARY INFORMATION: Are funds budgeted? YES NO If yes,
 TOTAL DOLLAR AMOUNT: \$1,773,581 (\$185,800 is Homeland Defense Funds; \$538,036 Previously Approved)
 SOURCE OF FUNDS: Citywide Waterfront Improvements, FIND Waterways Assistance Program and Sunshine State
 Financing Commission
 ACCOUNT CODE(S): 326015

If grant funded, is there a City match requirement? YES NO
 AMOUNT: _____ EXPIRATION DATE: _____
 Are matching funds budgeted? YES NO Account Code(s): _____
 Estimated Operations and Maintenance Budget _____

3. SCOPE OF PROJECT:
 Individuals / Departments who provided input: CIP
 DESCRIPTION OF PROJECT: The project consists of design, engineering and surveying of the Dinner Key Marina
 Anchorage project. Installation of anchors and the construction of the upland. (See attached memo for details).

ADA Compliant? YES NO N/A

Approved by Audit Committee? YES NO N/A DATE APPROVED: 1/21/09
 Approved by Bond Oversight Board? YES NO N/A DATE APPROVED: 1/27/09
 Approved by Commission? YES NO N/A DATE APPROVED: _____
 Revision(s) to Original Scope? YES NO (If YES see Item 5 below)
 Time Approval 6 months 12 months Date for next Oversight Board Update: _____

4. CONCEPTUAL COST ESTIMATE BREAKDOWN
 Has a conceptual cost estimate been developed based upon the initial established scope? YES NO If yes,
 DESIGN COST: _____
 CONSTRUCTION COST: _____
 Is conceptual estimate within project budget? YES NO
 If not, have additional funds been identified? YES NO
 Source(s) of additional funds: _____

Approved by Commission? YES NO N/A DATE APPROVED: _____
 Approved by Bond Oversight Board? YES NO N/A DATE APPROVED: _____

5. REVISIONS TO ORIGINAL SCOPE
 Individuals / Departments who provided input: _____
 Justifications for change: _____
 Description of change: _____

Fiscal Impact YES NO HOW MUCH? _____
 Have additional funds been identified? YES NO
 Source(s) of additional funds: _____

Time impact _____
 Approved by Commission? YES NO N/A DATE APPROVED: _____
 Approved by Bond Oversight Board? YES NO N/A DATE APPROVED: _____

6. COMMENTS: _____

APPROVAL: _____ DATE: 1/27/09
 BOND OVERSIGHT BOARD

CITY OF MIAMI, FLORIDA
INTER-OFFICE MEMORANDUM

TO: Ola Aluko, Director
Capital Improvements Department

DATE: May 28, 2008 FILE: B-33511

FROM: Carlos Vasquez
Construction Manager, CIP

SUBJECT: PAF for DKM
Mooring Field



Description:

The attached Project Analysis Form, (PAF) and Work Order authorization for Professional Services, are to approve funds and scope of work for the above referenced project. The Future Funds, (Sunshine State Bonds) was appropriated on March 13, 2008 per resolution No: 080125

Justification:

Based on Federal and State permit requirements, additional field investigation is necessary to expand field areas 3 and 4 to account for the relocated moorings currently estimated at 20-30 moorings to maintain the total of 225 moorings.

Scope of Work:

Hydrographic Survey, Jet Probes, Base Map, Permit Modification Processing, Site Visit to Marathon Mooring Field, Additional Meetings.

Funding:

The total cost to cover the design and production phase has been estimated at \$ 100,331.00 which is sufficient to fund the additional \$20,318.00

The project funding are as follows:

385200-1	2002 Homeland Defense Bonds series 1 326015	\$	108,836.00
385200-2	2002 Homeland Defense Bonds series 1 326015	\$	615,000.00
888920	FIND Waterways Assistance Program	\$	424,745.00
888961	Sunshine Financing Commission	\$	625,000.00
		\$	1,773,581.00

It is recommended to approve the attached Work Order for Professional Services to proceed with the required work

Cc: David J. Mendez, P.E Assistant Director Capital Improvements
~~Gary Fabrikant, Assistant Director Capital Improvements~~
Yvette Maragh, CIP Administrator Capital Improvements
Job File



PROJECT ANALYSIS FORM

Capital Improvements & Transportation

 CIP

 NON-CIP

Date Prepared: 28-May-2008

VERSION ORIGINAL

PROGRAM 325-Public Facilities

AREA 2-Recreation & Culture



PROJECT NAME: Dinner Key Mooring Field Project		PROJECT NO: B-33511
ADDRESS / LOCATION: 3400 Pan American Drive		DISTRICT: 2
PROJECT TEAM: Vertical	PROJECT CONTRACTED COST: \$ 180,520.11	
CATEGORY: Marinas	PROJECT EST. COST: \$ 1,773,581.00	
CLIENT DEPT: 35-CCF-Conf. Conv. & Public Facil.		CURRENT FUNDS: \$ 1,773,581.00
CLIENT CONTACT: Daniel Newhoff	TEL.: (305) 579-6247	FUTURE FUNDS:
DESIGN MANAGER: Steve Bogner	TEL.: 305-579-6950	FUND SHORTFALL:
CONSTR. MANAGER: Carlos Vasquez (CIP)	TEL.: 305-416-1206	PROCUREMENT: Conventional
EST. DESIGN START: 09/01/05	EST. BID ADV.: 08/04/08	EST. CONSTRUCTION START: 01/05/09
EST. DESIGN END: 12/01/07	EST. AWARD DATE:	EST. CONSTRUCTION END: 07/01/10

PROJECT ESTIMATED AND ACTUAL COSTS	PRODUCTION PHASE (3-DES)		% of Const	Estimated Design	% of Const.	Contracted Design	
	Prime Consultant: 2509 Blue Water Marine Services, Inc.	CODE					
	1 Outside Consultant - Prime Basic Design Fee	1.01	9.8%	\$ 130,000.00			
	2 Outside Consultant - Additional Design Services	1.01	1.0%	\$ 13,000.00			
	3 CIP - Design Management	1.04	0.9%	\$ 11,971.00			
	4						
	PRODUCTION TOTALS			Estimated	Contracted		
				\$ 154,971.00	\$ 76,303.50		
	CONSTRUCTION PHASE (4-CON)		CODE	Estimated Construction by PM		Contracted Construction (Formal Bid, Informal Bid or JOC Method)	
	Prime Contractor:						
1 Construction Cost (Prime Contractor)	2	90%	\$ 1,200,000.00				
2 Construction Contingency Allowance	2	9%	\$ 120,000.00				
3 Construction Material & Testing	2	1%	\$ 10,109.00				
4							
CONSTRUCTION TOTALS			Estimated	Contracted			
			\$ 1,330,109.00	\$ 104,216.61			
CONSTRUCTION ADMINISTRATION (8-CEO)		CODE	Estimated CEO		Contracted CEO		
1 Construction Engineering Observation (CEO) Consultant	3.01	4.0%	\$ 53,204.00				
2 Construction Inspections by CIP Inspector	3.02	1.5%	\$ 19,952.00				
3							
CONSTRUCTION ADMINISTRATION TOTALS			Estimated	Contracted			
			\$ 73,156.00				
ADMINISTRATIVE EXPENSES (6-ADM)		CODE	Estimated ADMIN		Contracted ADMIN		
1 CIP Department (Mgmt./Budget/Procurement/Comm.)	4	3.6%	\$ 48,250.00				
2							
ADMINISTRATIVE EXPENSES TOTALS			Estimated	Contracted			
			\$ 48,250.00				
ADDITIONAL PROJECT TASKS		CODE	Estimated TASKS		Contracted TASKS		
1 ACQUISITION EXPENSES (1-LAQ)	7						
2 PLANNING (2-PLN)	6						
3 EQUIPMENT (5-EQU)	5		\$ 50,411.00				
4 OTHER EXPENSES (7-OTH)	0		\$ 116,684.00				
5							
ADDITIONAL PROJECT TASKS TOTALS			Estimated	Contracted			
			\$ 167,095.00				
B-33511 PROJECT-GRAND-TOTAL			Estimated	Contracted			
			\$ 1,773,581.00	\$ 180,520.11			

PROJECT SCOPE	Design, engineering and surveying of the Dinner Key Marina Anchorage Project. Installation of the anchors and the construction of the upland. <input type="checkbox"/>					
	Operating Cost Associated with Project:					
	YEAR 1	YEAR 2	YEAR 3	YEAR 4	YEAR 5	

Notes	
-------	--

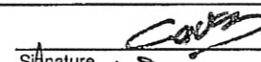
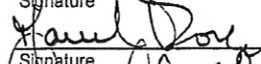
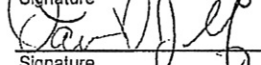
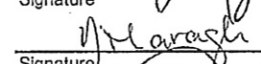
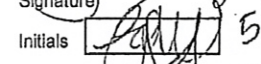
FUND SOURCES	AWARD NAME AND NUMBER	AVAILABLE	FUTURE
	385200-1 2002 Homeland Defense Bonds (Series 326015 Citywide Waterfront Improv	\$ 108,836.00	
	385200-2 2002 Homeland Defense Bonds (Series 326015 Citywide Waterfront Improv	\$ 615,000.00	
	888920 FIND Waterways Assistance Program F 326015 Citywide Waterfront Improv	\$ 424,745.00	
	888961 Sunshine State Financing Commission 326015 Citywide Waterfront Improv	\$ 625,000.00	
B-33511 FUND GRAND TOTAL	ACTUAL \$ 1,773,581.00	PROJECTED	

VALIDATION	Initiated by: <u>Carlos Vasquez</u> Project Manager		Date: <u>5/29/08</u>
	Approved by: <u>Marcel Douge</u> Senior Project Manager		Date: <u>5/30/08</u>
	Reviewed by: <u>David Mendez</u> Assistant Director: Capital Improvements		Date: <u>6/10/08</u>
	Reviewed by: <u>Yvette Maragh</u> CIP Budget Administrator		Date: <u>5/29/08</u>
	Verified by: <u>Edwige De Crumpe / Program Controls Staff</u>	Initials: <u>[Signature]</u> <u>5/28/08</u>	
	Accepted by: <u>Ola Aluko</u> Director: Capital Improvements		Date: <u>6/13/08</u>
	Approved by: <u>Daniel Newhoff</u> Assistant Director		Date: <u>12/16/08</u>
	ORIGINAL TO: <u>Melanie Whitaker / 10th Floor South Conference Room</u>	Initials: <u>[Signature]</u>	

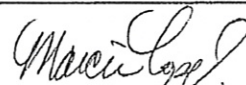
Notes	Receipt of PAF by Danette Perez - CIP Public Relations Coordinator <u>Project MUST be Presented to the Bond Oversight Board</u> 12/22/08  Date Received / Signature or Initials
-------	---

Executed PAF MUST be electronically distributed to the following individuals:
 Director of the Client Department, Yvette Maragh, Edwige De Crumpe, Senior Project Manager and Project Manager.

2. City Hall Emergency Chattahoochee Removal

NAME OF PROJECT: CITY HALL EMERGENCY CHATTAHOOCHEE REMOVAL
TOTAL DOLLAR AMOUNT: \$1,968.00
SOURCE OF FUNDS: Historic Preservation Initiatives
ACCOUNT CODE(S): CIP # 327001
DESCRIPTION OF PROJECT: The project consists of the removal of existing Chattahoochee stone covering at the rear steps entrance at City Hall to prevent slippage by the voters entering to vote.

HD/NIB MOTION 09-02

A MOTION TO FUND THE CITY HALL EMERGENCY CHATTAHOOCHEE REMOVAL.

MOVED: M. Cruz
SECONDED: L. Cabrera
ABSENT: H. Arza, L. Cabrera, K. Apfel, C. Matos, J. Reyes

Note for the Record: Motion passed by unanimous vote of all Board Members present.

3. Additional Funding for Dinner Key Mooring Field

NAME OF PROJECT: ADDITIONAL FUNDING FOR DINNER KEY MOORING FIELD
DOLLAR AMOUNT: \$1,773,581 (\$185,800 is Homeland Defense Funds; \$538,036 Previously Approved)
SOURCE OF FUNDS: Citywide Waterfront Improvements, FIND Waterways Assistance Program and Sunshine State Financing Commission
DESCRIPTION OF PROJECT: The project consists of design, engineering and surveying of the Dinner Key Marina Anchorage project. Installation of anchors and the construction of the upland. (See attached memo for details).

ITEM WITHDRAWN FROM AGENDA; CURRENTLY UNDER CONE OF SILENCE.

IV. UPDATES:

1. Marine Stadium Marina Improvements

Eileen Broton reported that the project will add an additional 53 racks to the marina for boat storage. An engineering firm has been assigned to design and provide the construction documents. The project is part of the Virginia Key Master Plan. The exact location for where the racks will be placed is still being decided and that seems to be why there's a slight delay. The exact location will drive the design and the construction. The time line for this project is June 2009 for completion.

12, picnic pavilion awnings. This is in the rear of our property. This project's complete, came in \$7 under budget; 100 percent complete, and this is on the north end of our property. Probably our best estimate to date. Lightning protection, \$7,550 was set aside. We only needed to put electric rod on the top of the carousel building. Two other buildings that we were anticipating having to do that work to after we had an analysis done; they were grounded in such a way that it was not needed. That was our administrative modular building and our historic concession stand. And so there was a savings there. Additional parking lot improvements. This was asphalt work again near our front entry. Where you enter a U-turn area, because we had to create a very different vehicular pathway in having folks come in, pay an entry and then whether or not they were at the wrong property and needed to U-turn and head directly out. So there's a section that loops around right at our entryway. That work was completed and there were some cost savings. Awnings for the administrative office, this was literally for our front door and rear door on our modular buildings, so while it's raining just for some coverage. It's an item that we chose later not to go ahead with and we deal with any rain that may come down with an umbrella just out of the front of the office. So it's something that we went ahead and cancelled. Mini train tunnel doors. This is a project that it's ongoing. It's in process right now, purchase orders have gone forward. We got our final bids. These are to replicate the historic cottage style wooden doors for our mini train tunnel. For security for the train because that is where it's parked at night. It's currently locked in with chain-link fence, and we want to complete the historic look of the tunnel and the train. And so that is something that I believe we will have complete in 60 to 90 days. All of the bidding is done and the company has been selected. Mini train rail installation. This included installing the rail, bolts, ties, everything else needed for that process. It did go over our estimate, just over \$25,000. It's 100 percent complete and has begun running as of August last year, the mini train. Mini train painting; that, too, was already complete; did go over, just around \$3,000. And that's project 18. Project 19, mini train platform restoration and awnings. This is the mini train station. What's existing on the park is essentially 110 by 10 foot concrete slab. The covering that was historically there has been gone potentially for decades. We're in the process now, from photographs and historic documents, of replacing that awning. It will be slightly modernized, but it will be very much a replica of what existed there. The company has been selected and actually the design of the awning is done, and in two and a half weeks, they will begin installation. Project number 20, park maintenance facility. This is a project, we cancelled it. Initially, when we brought a concessionaire into our concession stand building, which was a location with some offices where our operations staff used to reside. We were able to move them into our existing modular building. This initially was to put a trailer on property. We were able to not do that, keep some of the historic look of the property and move them into existing buildings, and it has worked out nicely. Finally is the children's play area. This was a boundless playground where we had set aside \$75,000 to match funds coming from the Children's Trust, and at the final hour, the Children's Trust was able to pay for the project 100 percent. And so our \$75,000 in matching was not needed and also went into surplus funds and was 100 percent complete. That concludes my update.

4. Dinner Key Mooring Anchorage Field

➤ Dinner Key Pier 3 Emergency Repairs (Reallocation)

Carlos Vasquez, CIP Department, reported that the Dinner Key mooring field project started about a year ago with the idea to be three projects in one. A decision was made with the client department, Public Facilities, to split the project into three separate projects, Dinner Key Mooring Field, Pier 3 repairs, and also another project for the Dinner Key Mooring Fields facility. The mooring field project is estimated to be completed by the end of July 2009.



DEPARTMENT OF CAPITAL IMPROVEMENTS
PROJECT OVERVIEW FORM

PREVIOUSLY APPROVED

1. DATE: 3/21/03
 NAME OF PROJECT: Dinner Key Mooring Anchorage Field Project
 INITIATING DEPARTMENT/DIVISION: Conferences, Conventions, and Public Facilities
 INITIATING CONTACT PERSON/CONTACT NUMBER: Alex Argudin 305.579.6341
 C.I.P. DEPARTMENT CONTACT:
 RESOLUTION NUMBER: R-03-337 CIP/PROJECT NUMBER:
 ADDITIONAL PROJECT NUMBER: _____
 (IF APPLICABLE)

2. BUDGETARY INFORMATION: Are funds budgeted? YES NO If yes,
 TOTAL DOLLAR AMOUNT: \$1,022,100
 SOURCE OF FUNDS: \$ 538,036 ACCOUNT CODE(S): 326015
Homeland Defense Citywide CIP #
Waterfront Improvements
 If grant funded, is there a City match requirement? YES NO
 AMOUNT: \$538,036 EXPIRATION DATE:
 Are matching funds Budgeted? YES NO Account Code(s):
 Estimated Operations and Maintenance Budget

3. SCOPE OF PROJECT:
 Individuals / Departments who provided input: Alex Argudin and Mary Whitehead
 DESCRIPTION OF PROJECT: Public Boat Docking and Mooring Facilities. This project will provide for moorings for transient vessels, the latest environmentally safe embedment anchors, facilities will also provide pump out operations to eliminate discharge of waste.

ADA Compliant? YES NO N/A
 Approved by Audit Committee? YES NO N/A DATE APPROVED: 3/21/03
 Approved by Bond Oversight Board? YES NO N/A DATE APPROVED: 3/25/03
 Approved by Commission? YES NO N/A DATE APPROVED: 3/17/03
 Revisions to Original Scope? YES NO (If YES see Item 5 below)
 Time Approval 6 months 12 months Date for next Oversight Board Update: 9-24-03

4. CONCEPTUAL COST ESTIMATE BREAKDOWN
 Has a conceptual cost estimate been developed based upon the initial established scope? YES NO If yes,
 DESIGN COST:
 CONSTRUCTION COST:
 Is conceptual estimate within project budget? YES NO
 If not, have additional funds been identified? YES NO
 Source(s) of additional funds:

Approved by Commission? YES NO N/A DATE APPROVED:
 Approved by Bond Oversight Board? YES NO N/A DATE APPROVED:

5. REVISIONS TO ORIGINAL SCOPE
 Individuals / Departments who provided input:
 Justifications for change:
 Description of change:

Fiscal Impact YES NO HOW MUCH?
 Have additional funds been identified? YES NO
 Source(s) of additional funds:

Time impact
 Approved by Commission? YES NO N/A DATE APPROVED:
 Approved by Bond Oversight Board? YES NO N/A DATE APPROVED:

6. COMMENTS: Find Grant Cost \$484,064
 APPROVAL: Robert O. Jorda DATE: 5-8-2003
 BOND OVERSIGHT BOARD

IV. ADDITIONAL ITEMS.

Alejandra Argudin of the Department of Conferences, Conventions and Public Facilities appeared before the Board concerning an emergency request for funding (approximately \$538,000) of the Dinner Key Mooring Anchorage Field Project. The Department is applying for a FIND Grant (approximately \$484,000) for this project, and will be addressing the Commission at the March 25, 2003 Commission meeting regarding this project.

HD/NIB MOTION 03-25

A MOTION TO RECOMMENDED APPROVAL BY THE HOMELAND DEFENSE/NEIGHBORHOOD IMPROVEMENT BOND OVERSIGHT BOARD OF THE DINNER KEY MOORING ANCHORAGE FIELD PROJECT.

**MOVED: L. de ROSA
SECONDED: M. REYES
ABSENT: S. ARMBRISTER; R. CAYARD; M. LOYAL;
D. MARKO**

Note for the Record: Motion passed by unanimous vote of all Board Members present.

HD/NIB MOTION 03-28

A MOTION TO ADJOURN TODAY'S MEETING.

**MOVED: M. REYES
SECONDED: M. CRUZ
ABSENT: S. ARMBRISTER; R. CAYARD; M. LOYAL;
D. MARKO**

Note for the Record: Motion passed by unanimous vote of all Board Members present.

7. Dinner Key Mooring & Anchorage Field Project.

The project is proceeding well. A typewritten status report on various phases of the project was provided to the Board. An update will be provided to the Board within six months.

III. CHAIRPERSON'S OPEN AGENDA:

Board Member Reshefsky reminded the Board of the necessity of attending Audit Subcommittee meetings as often as possible.

Chairman Flanders recognized the immense amount of work covered by the Audit Subcommittee on behalf of the Board. He further reminded both the Board and City staff of the importance of participating in the work of the Audit Subcommittee and the importance of attending all BOB meetings. He endorsed the requests of Board Members Reshefsky and Marko to have responsibilities of the Audit Subcommittee rotated among all members of the Board.

IV. ADDITIONAL ITEMS:

No additional items.

Meeting adjourned at 8:16 p.m.

UPDATES:

1. Model City Trust original \$1,800,000 for Replacement of HOME Investment Partnership Funds.

Report by Marva Wiley, Acting President of the Model City Community Revitalization District Trust. A finalized list as to what needs to be refunded is being prepared. Initially, the supporting documentation for the \$1.8 million that was requested reflected a list of properties thought to have been acquired between February and May of 2002. The number that the City is requesting be refunded is now \$2.4 million, reflecting several properties. There is a need to increase the amount to capture the full impact of the full list of acquisitions up to the present. Present total amount is \$3.6 million. \$2.4 million of that amount represents refunding of HOME funds or addressing prior acquisitions and additional payments charged for acquisitions through HOME funds and approximately \$1.2 million represents current acquisitions. Bond counsel will provide a written opinion as to whether or not the manner in which the exchange/replacement/transfer of funds is being suggested is legal.

2. Model City Trust's Office Renovation at Hadley Park.

Report by Marva Wiley, Acting President, Model City Community Revitalization District Trust. Ms. Wiley presented the Board with pictures of office renovations of the existing meeting room. The Trust moved into the office in January 2004.

3. Dinner Key Mooring & Anchorage Field Project.

Report by Alexandra Argudin - Conferences, Conventions and Public Facilities Dept. The permit applications for the construction of the Mooring Facility was submitted to the Federal, State and County regulatory agencies January 12, 2004. The Marina Manager and Ms. Argudin met with the permitting representatives of these agencies on February 25, 2004 at Dinner Key to discuss the project, provide a tour of the anchorage and respond to some of the initial questions the agencies had re the project. A formal response to those questions from the City's consultant to the agencies is being prepared and will be submitted by April 11, 2004. The balance of the permitting process includes responding to questions and requests for additional information from the agencies, and it is hoped that the permitting process will be completed by the latter part of this year. To date, the City has expended \$49,125 in engineering and consulting expenses related to the preparation

and submittal of agency permit applications, and \$7,288 in permit application fees. Approximately \$15,000 will be expended in the removal of derelict vessels and other debris from the Dinner Key Anchorage area. These costs are all associated with Phase 1 of the project. Phase II will entail the actual construction of the mooring field and upland facilities. All permits should be in place by the end of the year.

4. Virginia Key Beach Park Improvements, Renovations & Repairs – Phase I

Report by Sandra Vega and Alberto Corales - CIP Dept. The project is 70 percent complete. The project is expected to be completed by July 2004. The structures that are presently being repaired are the carousel, the small bathhouse, the concession building, the tunnel, the large bathhouse the dance floor and a number of pavilions. The project is advancing according to schedule and according to budget. Photographs of the work in progress were presented to the Board.

5. Police Homeland Defense Preparedness Initiatives

Report by Major Joseph Longueira - Police Department. A spreadsheet of the status of acquisitions was provided to the Board followed by a Power Point presentation which indicated what acquisitions have been made and what acquisitions are pending.

6. FEC Corridor Initiatives.

Report by Carmen Sanchez - Economic Development Dept.; Enrique Nunez - Planning and Zoning Dept; Jorge Cano, CIP Dept. A handout of the work in progress was provided to the Board. The Department of Economic Development issued a Request for Qualifications (RFQ) to find adequate consultants to provide a transportation/financing/marketing plan. At present, one response was received re the financing component of the plan and only a couple of responses were received re the marketing and transportation components of the plan. The Purchasing Department suggested that the RFQ be re-released as individual components rather than as a group in hopes of getting a better pool from which to choose an adequate consultant to carry out the services and Economic Development is in the process of following up on this suggestion. The Department of Transportation has brought in a pool of industry consultants to review the scope of infrastructure element needs for that area and once all studies are done, a plan will be developed re infrastructure needs for the area. The FEC Regulating Plan

APPROVED BY AUDIT COMMITTEE: not approved; Audit Subcommittee asked for additional information to be presented at the 10-27-04 BOB Meeting. A presentation was made by Major Mirabile to explain how this project was for decontamination and there was a unanimous show of hands in favor of this project by the seven board members present.

UPDATES:

1. Dinner Key Mooring Anchorage Field Project.

Steven Bogner presented status report. The permit process is expected to be completed by the end of 2004. Army Corp of Engineers are expected to approve the project soon. Mr. Bogner will come back with another status report in three months.

2. Preservation Development Initiative Grant.

Sarah Eaton expressed disappointment in not having much progress to report. The grant, which is for technical assistance only (no money), is pending at the mercy of the national trust. Ms. Eaton continues to pursue this and will return in six months with another report.

3. Little Haiti Park Land Acquisition 254 NE 59 Terrace, Parcel 68.

Dirk Duval, reported that the land had been acquired.

4. Little Haiti Park Demolition of Structure and Removal of Debris

at 254 NE 59 Terrace, Parcel 68. Dirk Duval, reported the structure was demolished, secured and fenced in.

5. Procurement of Appraisal Services for Little Haiti Park.

Dirk Duval, reported that 10 appraisals had been procured and would return with recommendation for condemnation proceedings on certain properties.

6. Brentwood Village – Professional Services.

Jorge Cano reported this project is temporarily on hold and would bring the issue back on the next agenda.

7. Bicentennial Park Seawall/Shoreline Stabilization – Phase I.

Jorge Cano reported this project is well underway and is about two months ahead of schedule.

8. Coral Way Beautification Uplighting – Phase I.

Jorge Cano reported this project is pending profile requested by Florida Department of Transportation, which should be complete next week. The project is expected to move at a rate of approximately 2-3 blocks per week.

9. Site Furnishings at Coral Gate Park.

Ed Blanco reported this project is completed and photographs were available.

10. Site Furnishings at Jose Marti Park.

Ed Blanco reported this project is complete and the park is looking better.

- Trust has been successful in receiving other grants, some of them to remediate brownfields (contaminated lands). Some of the HD/NIB funds are to be used as matching funds for remediation of contaminated lands.
- A second priority for the Trust is addressing the digital divide by implementing a hot zone to create the opportunity for residents of the area to have access to the internet.
- Lastly, infrastructure improvements will be addressed.

Ms. Wiley further stated that no one has moved into houses yet. The first priority of the Trust was to acquire all properties prior to beginning construction. The reason for this is once you construct houses, the value of area properties increases. Master plan was approved in 2004. There are 86 properties currently in the inventory; of that 26 are slated for single family homes. There are 16 houses ready for implementation. The past six months have been processing necessary permits.

3. Dinner Key Mooring Anchorage Field Project.

Steven Bogner, Marinas Manager, Department of Public Facilities, reported that: (1) the engineering and permitting consultant is in regular contact; (2) preparing to remove 11 derelict and sunken vessels from project area within the next 45 days and identifying additional vessels to be removed; (3) submitting applications for Florida Inland Navigation District for grant monies.

4. Dinner Key Marina Fuel Dock.

Steven Bogner, Marinas Manager, Department of Public Facilities, reported that permit approvals for fuel dock have been secured; construction phase of project has been put out to bid and responses are due March 22, 2005. The next step is the evaluation of proposals by the CIP Dept. and the approval of the contract by the City Commission.

5. Baywalk Improvements at One Miami Site.

Kevin Brown, CIP Dept., reported this walkway along the Miami River is expected to be completed by September or October 2005. Project includes art pieces and water fountain.

6. Neo Lofts Greenway Segment.

Kevin Brown, CIP Dept., reported that a pre-construction meeting took place on February 3rd. Notice to proceed with contract was issued on February 13th. Currently, contractor is acquiring necessary permits. Expecting construction to begin next week. Gary Reshefsky requested before and after photographs. Robert Flanders requested photographs be posted on the board website.

3. Neighborhood Fire Stations & Training Facility

Assistant Fire Chief Tom Flores, reported that when the Homeland bond first began, it was broken down into three fire stations and the training center where the money would be spent. The money was allocated for those four projects. The Department expended money without coming back before the Homeland Board, to lease trailers for use as stations, and to improve sites where the stations were located. In the Department's search for property, appraisals were done that use Homeland bond monies. Lately, the fire fee and other funds have been used to cover the costs of appraisals.

Nikki Lorenzo, Public Facilities, reported that closing was completed on October 21, 2005, on the property on 990 Northeast 79th Street, purchased for 900,000. The other two properties, 958 and 960 Northeast 79th Street, for 1,050,000, closing is expected to be completed next week.

Assistant Fire Chief Tom Flores, reported that one of the properties has a year lease, but the Department will be working with architects and engineers to begin the design process. Station 11 has an architect and engineer company already in the design process.

4. Dinner Key Mooring Anchorage Field Project

Stephen Bogner, Public Facilities, reported that construction drawings and engineer have been completed on this project. Permits have been submitted to the agencies. A notice of intent to issue permit was received from the Florida Department of Environmental Protection, the lead regulatory agency on the project. A Miami citizen objected to the project and filed a petition for administrative hearing. The DEP denied that request and offered that individual 15 days to submit an amended petition. The end of the 15-day period is approaching. When the final permits are secured from all the agencies on this project, the Department will move forward with securing the balance of the funding for this project, which is estimated to be between 750,000 and \$1 million. This project has not taken money out to remove sunken vessels throughout the planned mooring field project area. The Department is hoping to secure FEMA funding for debris removal. Next steps are securing funding, and concurrent with that is continuing to remove the derelict vessels from the mooring field project vessel and citywide.

5. Dinner Key Marina Fuel Dock

Mary Conway, CIP & Transportation, reported that CIP is in the process of executing the contract with the contractor. Construction is anticipated to begin in late January.

6. Environmental & Title Services for Little Haiti Park Parcels 18, 60 & 61

Madeline Valdes, Public Facilities, reported that all title issues on the properties have been resolved.

7. Underground Storage Tank Removal at Little Haiti Park Parcels 60 & 61

Madeline Valdes, Public Facilities, reported that underground tanks were removed on properties, and a clearance letter was obtained from DERM.

I. **APPROVAL OF THE MINUTES OF THE MEETING OF MAY 23, 2006.**

NOT TAKEN UP DUE TO LACK OF QUORUM.

II. **NEW BUSINESS:**

NEW ITEM:

- Additional Increase in Contract for Enhancements to NW 14th Street Improvements Project

NOT TAKEN UP DUE TO LACK OF QUORUM.

UPDATES:

1. Dinner Key Mooring Anchorage Field Project

Stephen Bogner, Public Facilities, reported that the City has received permit approvals from the FDEP and the Army Corps of Engineers for the project. Permits remaining to be obtained are Dade County DERM and the City of Miami, and the City is in the final stages of receiving permit approvals from those agencies. This past Friday, the City presented a formal grant application to the Florida Inland Navigation District, in Coco Beach, for matching grant funding for the balance of the project. The presentation was well-received by the FIND Commission, and a positive outcome is anticipated for late August. The latest round of sunk and abandoned and derelict vessel removal citywide was recently completed, which included the removal of sunken vessels and debris in the project area. Next steps for the project are to complete the outstanding permitting requirements with Dade County DERM, obtain the matching grant from the Florida Inland Navigation District that will enable the Department to begin construction, and then initiate construction. If everything goes according to plan, construction is anticipated to begin in October of this year, with completion of the project in June 2007.

Rolando Aedo questioned whether the current project had any correlation with the fuel station project. Mr. Bogner stated that the fuel project would support the mooring field in that there would be a dedicated pump-out facility located at the fuel dock. In addition, there would be an additional source of projected revenue from customers out in the mooring field.

Rolando Aedo asked if there was anything new to report on the fuel dock project. Mr. Bogner stated he had nothing new to report since the last meeting where the resolution was passed to address the Commission and the Administration of the Board's concerns and desire to put the project back on track.

Chairman Flanders requested that Gary Fabrikant discuss the CIP Department's updates with the Board, so that the Board, within the course of a month before the meeting, understands what is going on before the meeting.

2. Police Training Facility Professional Services

Maria Liz Babun-Matos, Police Department, reported that the City has a contract with Spillis Candela, the architects that have been selected for the project. The project is currently in the programming and schematic stage. The Department has had several meetings with them already and have selected schematic number 2 out of several schematics that they offered at the meeting. The Department has met with a programmer and outlined the

Note for the Record: Motion passed by unanimous vote of all Board Members present.

3. Lummus Park –Police Stables

Ola O. Aluko, CIP Director, requested that the item be pulled and brought back at a later date, if necessary. He stated that he will determine if the project change order will be funded with HD funds. If not, then the project will not be brought back before the Board.

UPDATES:

1. Dinner Key Mooring Anchorage Field Project

Stephen Bogner, Public Facilities, reported that the project entails the construction and installation of 225 moorings in the waters just offshore of Dinner Key Marina. The facility will be operated and managed by the City of Miami's Department of Public Facilities Marinas Division. Currently, engineering and permitting consultants in CIP are preparing construction documents for bid. The consultants are working to provide CIP with all of the information required to finalize 100 percent construction plans. The Department is working with the regulatory agencies on minor permit modifications and securing final Miami-Dade County DERM and City construction permits. No major problems are anticipated. City staff recently traveled to the municipally managed Boot Key Harbor Marina in Marathon, Florida to meet with their facility's staff and discuss startup and operational issues and tour the mooring field. Next, the Department hopes to finalize construction plans for bid and bid the project out by March 1, 2008. Construction is anticipated to begin by June 1, 2008. Construction completion is estimated for July 31, 2008, with the mooring field opening by September 1, 2008.

2. Fuel Dock At Dinner Key Marina

Ola O. Aluko, CIP Director, reported that the project is pretty much stalled mainly because of the waterfront master plan and other environmental issues that need to be ironed out. The design has been completed and the design drawings are being shelved for now. Once the Sasaki master plan is completed, the current design will be examined to determine if it is in conformance with the new master plan. If so, the project will be brought back and moved forward; if not, the necessary revisions will be made.

3. MiaMarina Pier 5 Dock Emergency Repairs

Stephen Bogner, Public Facilities, reported that the project is still an emergency after two-plus years. Bid documents are being prepared by consultants in the CIP Department to put the project out to bid. All of the regulatory agency permit approvals have been obtained. CIP is currently working on finalizing the City permit approvals. Next, construction plans will be finalized for bid and the project will be bid out by February 2008. Construction is anticipated to begin around April 1, 2008, with a completion date estimated for June 15, 2008.

4. Juan Pablo Duarte Park-Water Playground

Ed Blanco, Parks & Recreation Department, reported that a purchase order was issued May 2007, and the project is still in the design and permitting phase. There were concerns from the contractor this month that the soil at the park next to the recreation building is soft and they may have to excavate and put in new fill in order to complete the project.

5. West End Park-Water Playground

Jose Solares asked who will manage the parking garage. Mr. Riley stated that the garage will have a single operator for both buildings and the garage will be a fee parking garage, open to the public.

Mariano Cruz asked what the timetable is for the project. Mr. Riley stated that MAM is very anxious to start the project and would like to break ground in April.

Gary Reshefsky asked how much money has been drawn from the Homeland Defense account for the project. Mr. Riley stated that the project withdrew the entire \$2.7 million that was allocated for the project.

Gary Reshefsky requested that MAM return in April to give the Board another update on the project.

2. Police Sky Watch Observation Tower

Major Armando Guzman reported that the tower has been purchased and the project is complete. The tower is able to extend up to 24 feet in height and provides an elevated platform by which to direct police resources in crowd situations and traffic situations.

3. Gusman Hall Improvements

Carmen Matos stated that the Gusman Hall improvements were completed last month. All of the doors are now ADA compliant. The refreshment stand, emergency lighting, and impact windows were all put in. The County and State provided matching funds for the project.

4. Dinner Key Mooring Anchorage Field Project

Carmen Matos stated that the project is estimated to be completed August 2009 and will increase capacity by 225 moorings and will increase revenue.

Thelma Free, assistant to the director of Public Facilities, reported that estimations for revenue increases were based on percentage of capacity. At 25 percent, \$159,750 is estimated; 50 percent, \$319,500; 75 percent, \$479,250; and 100 percent, \$639,000. The project is days away from the start of the bid process. The plans are about 99 percent complete. Public notice for bids is estimated for November, and approval from the Commission should be received by December so that construction can begin.

5. Preservation Development Initiative Grant

Carmen Matos stated that the grant was for technical assistance to write the transfer of development rights code for the City. The historic preservation officer has already written the code and money was recently used for a survey in the Upper Eastside to help the neighborhood of Palm Grove move forward with historic preservation designation. The designation is in process and the funds have been successfully used. The project grant is completed.



DEPARTMENT OF CAPITAL IMPROVEMENTS
PROJECT OVERVIEW FORM

Dinner Key Mitigation
ADDITIONAL FUNDING UPDATE

COMPLETED

1. DATE: 6/24/08 DISTRICT: 2
NAME OF PROJECT: Additional Funding for Dinner Key Dredging
INITIATING DEPARTMENT/DIVISION: Public Facilities
INITIATING CONTACT PERSON/CONTACT NUMBER: Sandra Vega (305) 416-1243
C.I.P. DEPARTMENT CONTACT: Ola O. Aluko (305) 416-1280
RESOLUTION NUMBER: _____ CIP/PROJECT NUMBER: B-30247

2. BUDGETARY INFORMATION: Are funds budgeted? YES NO If yes,
TOTAL DOLLAR AMOUNT: \$2,300,000 (\$1,631,900 is Homeland Defense; \$278,000 was previously approved)
and \$390,000 is FIND Waterways Assistance Program Funds.

SOURCE OF FUNDS: Citywide Waterfront Improvements and FIND Waterways Assistance Program Funds

If grant funded, is there a City match requirement? YES NO
AMOUNT: _____ EXPIRATION DATE: _____
Are matching funds budgeted? YES NO Account Code(s): _____
Estimated Operations and Maintenance Budget _____

3. SCOPE OF PROJECT:

Individuals / Departments who provided input: _____

DESCRIPTION OF PROJECT: This project consists of the engineering and implementation of dredging approximately 10,000 C.Y. for the main approach channel at the north end of the Marina. Also, the project includes the mitigation plan to place approximately 1,100 C.Y. of riprap as part of the DERM requirement.

ADA Compliant? YES NO N/A

Approved by Audit Committee? YES NO N/A DATE APPROVED: 6/18/08
Approved by Bond Oversight Board? YES NO N/A DATE APPROVED: 6/24/08
Approved by Commission? YES NO N/A DATE APPROVED: _____
Revisions to Original Scope? YES NO (If YES see Item 5 below)
Time Approval 6 months 12 months Date for next Oversight Board Update: _____

4. CONCEPTUAL COST ESTIMATE BREAKDOWN

Has a conceptual cost estimate been developed based upon the initial established scope? YES NO If yes,
DESIGN COST: _____

CONSTRUCTION COST: _____

Is conceptual estimate within project budget? YES NO
If not, have additional funds been identified? YES NO
Source(s) of additional funds: _____

Approved by Commission? YES NO N/A DATE APPROVED: _____
Approved by Bond Oversight Board? YES NO N/A DATE APPROVED: _____

5. REVISIONS TO ORIGINAL SCOPE

Individuals / Departments who provided input: _____

Justifications for change: _____

Description of change: _____

Fiscal Impact YES NO HOW MUCH? _____
Have additional funds been identified? YES NO
Source(s) of additional funds: _____

Time impact _____
Approved by Commission? YES NO N/A DATE APPROVED: _____
Approved by Bond Oversight Board? YES NO N/A DATE APPROVED: _____

6. COMMENTS:

APPROVAL: Robert O. Jones DATE: 6/24/08

BOND OVERSIGHT BOARD

Enclosures: Back-Up Materials YES NO

CITY OF MIAMI, FLORIDA
INTER-OFFICE MEMORANDUM

TO: Ola O Aluko, Director
Capital Improvements

DATE: November 7, 2008 FILE: B-30247A and
B-30247

SUBJECT: Dinner Key Mitigation
Project Analysis Form (PAF) and
Dinner Key Dredging
Project Analysis Form (PAF) Rev1

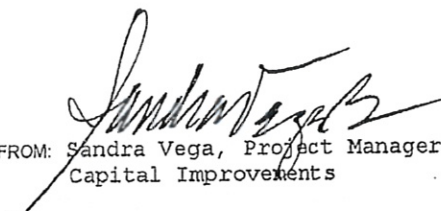
FROM: Sandra Vega, Project Manager
Capital Improvements

REFERENCES:

ENCLOSURES: Project Analysis Form PAF)
Project Analysis Form (PAF-
REV1)

The above named projects require the following:

Description:

The Dinner Key Mitigation Project B-30247A requires a Project Analysis Form.
The Dinner Key Dredging Project requires a Revision 1 to transfer the funds of the
Mitigation portion to The Dinner Key Mitigation Project B-30247A.

Justification:

The Dinner Key Mitigation Project B-30247A is ready to go Bid and it requires a Project
Analysis Form to establish the scope of work, the budget and the funds for the
administration and construction of the project.

The Dinner Key Dredging Project B-30247 requires a Revision 1 of its Project Analysis
Form (PAF) dated April 14th, 2008 to transfer the funds estimated of the Mitigation
portion.

Funding:

The total cost to fund the Dinner Key Mitigation is \$332,900.00

The project has funds from Homeland Defense Funds Series II (HD-2) to cover the
administration and construction costs.

Therefore it is recommended to approve the attached Project Analysis Form (PAF) B-30247A
and Project Analysis Forms (PAF-REV1) B-30247.

SV/sv

cc: David Mendez, Assistant Director Capital Improvements
Gary Fabrikant, Assistant Director Capital Improvements
Yvette Maragh, CIP Administrator Capital Improvements
 Marcel Douge, Senior Project Manager Capital Improvements



PROJECT ANALYSIS FORM

Capital Improvements & Transportation

CIP
 NON-CIP

Date Prepared:	28-Oct-2008
VERSION	ORIGINAL

PROGRAM 325-Public Facilities AREA 2-Recreation & Culture



PROJECT NAME: Dinner Key Dredging - Mitigation		PROJECT NO: B-30247A
ADDRESS / LOCATION: 3400 Pan American Dr		DISTRICT: 2
PROJECT TEAM: Vertical	PROJECT CONTRACTED COST:	
CATEGORY: Marinas	PROJECT EST. COST: \$	332,900.00
CLIENT DEPT: 35-CCF-Conf. Conv. & Public Facil.	CURRENT FUNDS: \$	332,900.00
CLIENT CONTACT: Daniel Newhoff	TEL.: (305) 579-6247	FUTURE FUNDS:
DESIGN MANAGER: Sandra Vega (CIP)	TEL.: 305-416-1243	FUND SHORTFALL:
CONSTR. MANAGER: Vertical TBD (CIP)	TEL.:	PROCUREMENT: Conventional
EST. DESIGN START: 12/15/08	EST. BID ADV.: 03/25/09	EST. CONSTRUCTION START: 07/25/09
EST. DESIGN END: 02/25/09	EST. AWARD DATE:	EST. CONSTRUCTION END: 10/20/09

PROJECT ESTIMATED AND ACTUAL COSTS	PRODUCTION PHASE (3-DES)			% of Const	Estimated Design	% of Const	Contracted Design
	Prime Consultant: 0000 To be Assigned		CODE				
	1	CIP - Design Management	1.04	5.0%	\$ 14,300.00		
	2	General Production Phase contingency	1.01	0.7%	\$ 2,000.00		
	3	Miscellaneous Services - Other	1.01	0.7%	\$ 2,000.00		
	4						
	PRODUCTION TOTALS				Estimated		Contracted
					\$ 18,300.00		
	CONSTRUCTION PHASE (4-CON)				Estimated Construction by PM	Contracted Construction (Formal Bid, Informal Bid or JOC Method)	
	Prime Contractor: 0000 To be Assigned		CODE				
1	Construction Cost (Prime Contractor)	2	91%	\$ 260,000.00			
2	Construction Contingency Allowance	2	9%	\$ 26,000.00			
3							
CONSTRUCTION TOTALS				Estimated		Contracted	
				\$ 286,000.00			
CONSTRUCTION ADMINISTRATION (8-CEO)				Estimated CEO	Contracted CEO		
		CODE					
1	Construction Engineering Observation (CEO) Consultant	3.01					
2	Construction Management by CIP Construction Manager	3.04	5.0%	\$ 14,300.00			
3	Construction Inspections by CIP Inspector	3.02					
4	JOC Administration - The Gordian Group	3.03					
5							
CONSTRUCTION ADMINISTRATION TOTALS				Estimated		Contracted	
				\$ 14,300.00			
ADMINISTRATIVE EXPENSES (6-ADM)				Estimated ADMIN	Contracted ADMIN		
		CODE					
1	CIP Department (Mgmt./Budget/Procurement/Comm.)	4	5.0%	\$ 14,300.00			
2							
ADMINISTRATIVE EXPENSES TOTALS				Estimated		Contracted	
				\$ 14,300.00			
ADDITIONAL PROJECT TASKS				Estimated TASKS	Contracted TASKS		
		CODE					
1							
ADDITIONAL PROJECT TASKS TOTALS				Estimated		Contracted	
B-30247A PROJECT GRAND TOTAL				Estimated		Contracted	
				\$ 332,900.00			

PROJECT SCOPE	DERM Mitigation requirement for the Dinner Key Dredging project. to place approx. 1,000 c.y. of RipRap in Spoil Islands B and D.					
	Operating Cost Associated with Project:	YEAR 1	YEAR 2	YEAR 3	YEAR 4	YEAR 5

Notes	
-------	--

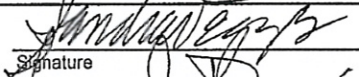
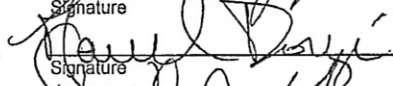
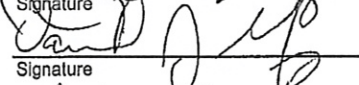
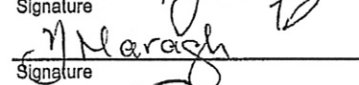
FUND SOURCES	AWARD NAME AND NUMBER	AVAILABLE	FUTURE
		385200-2 2002 Homeland Defense Bonds (Serit 326015 Citywide Waterfront Improv	\$ 332,900.00
	B-30247A FUND GRAND TOTAL	ACTUAL \$ 332,900.00	PROJECTED

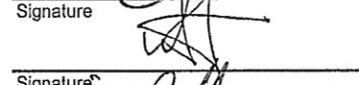
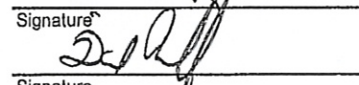
VALIDATION	Initiated by: <u>Sandra Vega</u> Project Manager		Date: <u>10/29/08</u>
	Approved by: <u>Marcel Douge</u> Senior Project Manager		Date: <u>10/29/08</u>
	Reviewed by: <u>David Mendez</u> Assistant Director: Capital Improvements		Date: <u>11/18/08</u>
	Reviewed by: <u>Yvette Maragh</u> CIP Budget Administrator		Date: <u>11/18/08</u>
	Verified by: <u>EDWIGE DE CRUMPE</u> Program Controls Staff	Initials: <u>ED</u> Signature: 	
	Accepted by: <u>Ola Aluko</u> Director: Capital Improvements		Date: <u>11/18/08</u>
	Approved by: <u>Daniel Newhoff</u> Assistant Director		Date: <u>11/24/08</u>
	ORIGINAL TO: Melanie Whitaker / 8th Floor		Initials: _____

Notes	Receipt of PAF by Danette Perez - CIP Public Relations Coordinator	<u>12/3/08</u>	
	<u>Project MUST be Presented to the Bond Oversight Board</u>	Date Received /	Signature or Initials

Executed PAF MUST be electronically distributed to the following individuals:
 Director of the Client Department, Yvette Maragh, Edwige De Crumpe, Senior Project Manager and Project Manager.

Dinner Key Marina Mitigation - Probable Opinion of Construction Costs

Description	Quantity	Unit	Unit Cost	Estimated Total
1. Mitigation				
a) Rip Rap ¹	990	cy	\$ 220	\$ 217,800
b) Contribution to the BBETF ²	30	cy	\$ 90	\$ 2,700
Subtotal Cost for Marine Works:				\$ 220,500
Mobilization/Demobilization (5%) :				\$11,025
General Conditions (3%) :				\$6,615
Bond (5%) :				\$11,025
Contingency (16.5%) :				\$36,383
Total Estimated Construction Cost :				\$ 285,548
Total Estimated Cost for Marine Works :				\$ 286,000

NOTES:

- 1 Estimated rip rap quantity based on permit sketches. Estimated rip rap unit cost provided by marine contractor (March 2008).
- 2 BBETF contribution quantity based on permit sketches. BBETF unit cost consistent with unit costs at original application date and confirmed by DERM (January 2008).
- 3 The cost estimates herein are made on the basis of Coastal Systems' experience and qualifications, and represent Coastal Systems' best judgment as an experienced and qualified professional generally familiar with the industry. However, Coastal Systems has no control over the cost of labor, materials, equipment, or services furnished by others, or over the Contractors' methods of determining prices, or over competitive bidding or market conditions. Coastal Systems cannot and does not guarantee that proposals, bids, or actual Construction Cost will not vary from the above estimates.

III. UPDATES:

1. Additional Funding for Dinner Key Dredging/Dinner Key Mitigation

Eileen Broton reported that the project design is complete and the bidding process will begin soon. The mitigation piece of the project was added in the initial cost of the entire project and that permit is forthcoming. There are two components of the project and those two components are separate at this point. CIP proposes to close this project number out and make it into two separate projects with the same number, but designated A and B.

2. Additional Funding for Henderson Park New Offices/Restroom Facility

Eileen Broton reported that the project was previously approved in 2007. The original estimate for the project was very low. The additional items on the project include improvements such as different lighting, landscaping and things that make the project nicer. The project design will be completed very soon and permitting is anticipated in 2009.

3. Additional Funding for Dorsey Park Building Renovation Expansion

Eileen Broton reported that the project scope includes a new gym and a new area for homework and aerobics. The structure is being expanded by approximately 1,000 square feet. The project includes upgraded lighting, the parking area, air conditioning systems and landscaping. The estimated completion of this work is February 2009.

4. Gibson Park Improvements Phase II

Eileen Broton reported that the project was completed. The major challenge on the project was the roof repair. The issue is that the project design had three different types of roofs for different sections so it took a lot of engineering to come up with a proper roof design so that it wouldn't leak. The project also included remodeling of the pool bathhouse, a new multipurpose building and a food prep building. The project came in close to the cost estimate for that phase.

IV. CHAIRPERSON'S OPEN AGENDA:

- **Annual Report**

Chairman Flanders reviewed the annual report additions with the Board. The new additions included the Board's project total to date and a paragraph stating that the CIP Department has returned trust to the City and integrity to the process, thus encouraging the City's elected officials to pursue the possibility of offering another bond program, voted by the citizens, that continues the rebuilding of Miami's infrastructure.

7. Shenandoah Park Improvements Phase IV

<p>NAME OF PROJECT: <u>SHENANDOAH PARK IMPROVEMENTS PHASE IV</u> TOTAL DOLLAR AMOUNT: <u>\$709,106.00</u> SOURCE OF FUNDS: <u>Neighborhood Park Improvements</u> ACCOUNT CODE(S): <u>331419</u> DESCRIPTION OF PROJECT: <u>PHASE IV: Remodel the Recreation Building, install a new HVAC system, install new insulation and ceiling drywall, install new movable partition, construct a new addition for Arts and Craft, and remodel the restroom facility.</u></p>

HD/NIB MOTION 09-26

A MOTION TO FUND SHENANDOAH PARK IMPROVEMENTS PHASE IV.

MOVED: G. Reshefsky
SECONDED: C. Grant
ABSENT: R. Aedo, H. Arza, L. Cabrera, K. Hancock-Apfel, R. Lambert, C. Matos, P. Perez-Cisneros

Note for the Record: Motion passed by unanimous vote of all Board Members present, with the exception of Jose Solares, who voted no on the motion.

III. UPDATES:

1. Additional Funding for Henderson Park New Offices/Restroom Facility

Gilbert Henric, CIP Department, reported that the project is on budget. A groundbreaking ceremony was scheduled for May 27. A preconstruction meeting was held last week. A notice will be given to the architect tomorrow to proceed. The plumbing issue was resolved through the Building Department. The paperwork is being filed to give the contractor the go-ahead.

2. Additional Funding for Dinner Key Dredging

AND

3. Dinner Key Mitigation

Carlos Vasquez, CIP Department, reported that the project is in the bid process. The recommendation to the City Manager is going to be issued probably at the end of this week. Both projects are still under the cone of silence. The project should begin late summer 2009, with an expected completion date at the end of the year or January 2010.

4. Dinner Key Marina Pier No. 3 Emergency Repairs

Eileen Broton stated that the project was completed May 2009, on budget.

Carlos Vasquez, CIP Department, reported that the project was an emergency project. The project was completed within a month and a half. The project is in the process of closeout documentation and completion of punch list items.



DEPARTMENT OF CAPITAL IMPROVEMENTS
PROJECT OVERVIEW FORM

COMPLETED

1. DATE: 5/26/09 DISTRICT: 2
 NAME OF PROJECT: MARINE STADIUM MARINA BOAT RACK METAL ROOF DECK REPLACEMENT
 INITIATING DEPARTMENT/DIVISION: Public Facilities
 INITIATING CONTACT PERSON/CONTACT NUMBER: Daniel Newhoff (305) 579-6247
 C.I.P. DEPARTMENT CONTACT: _____
 RESOLUTION NUMBER: _____ CIP/PROJECT NUMBER: B-33514D

2. BUDGETARY INFORMATION: Are funds budgeted? YES NO If yes,
 TOTAL DOLLAR AMOUNT: \$150,000 funds reallocated from Marine Stadium Marina Improvements

SOURCE OF FUNDS: Citywide Waterfront Improvements
 ACCOUNT CODE(S): 326015

If grant funded, is there a City match requirement? YES NO
 AMOUNT: _____ EXPIRATION DATE: _____
 Are matching funds budgeted? YES NO Account Code(s): _____
 Estimated Operations and Maintenance Budget _____

3. SCOPE OF PROJECT:

Individuals / Departments who provided input: _____
 DESCRIPTION OF PROJECT: The project consists of replacement of the rusted/damaged metal roof deck for two boat racks.

ADA Compliant? YES NO N/A

Approved by Audit Committee? YES NO N/A DATE APPROVED: 5/18/09
 Approved by Bond Oversight Board? YES NO N/A DATE APPROVED: 5/26/09
 Approved by Commission? YES NO N/A DATE APPROVED: _____
 Revision(s) to Original Scope? YES NO (If YES see Item 5 below)
 Time Approval 6 months 12 months Date for next Oversight Board Update: _____

4. CONCEPTUAL COST ESTIMATE BREAKDOWN

Has a conceptual cost estimate been developed based upon the initial established scope? YES NO If yes,
 DESIGN COST: _____
 CONSTRUCTION COST: _____
 Is conceptual estimate within project budget? YES NO
 If not, have additional funds been identified? YES NO
 Source(s) of additional funds: _____

Approved by Commission? YES NO N/A DATE APPROVED: _____
 Approved by Bond Oversight Board? YES NO N/A DATE APPROVED: _____

5. REVISIONS TO ORIGINAL SCOPE

Individuals / Departments who provided input: _____
 Justifications for change: _____
 Description of change: _____

Fiscal Impact YES NO HOW MUCH? _____
 Have additional funds been identified? YES NO
 Source(s) of additional funds: _____

Time impact _____
 Approved by Commission? YES NO N/A DATE APPROVED: _____
 Approved by Bond Oversight Board? YES NO N/A DATE APPROVED: _____

6. COMMENTS: _____

APPROVAL: Eileen Marcial Broton DATE: 5/26/09
 BOND OVERSIGHT BOARD

Enclosures: Back-Up Materials YES NO



PROJECT ANALYSIS FORM

Capital Improvements & Transportation

CIP
NON-CIP

Date Prepared:	13-May-2009
VERSION	ORIGINAL

PROGRAM 325-Public Facilities AREA 2-Recreation & Culture



PROJECT NAME: Marine Stadium Marina - Boat Rack Metal Roof Deck Replacement	PROJECT NO: B-33514D
ADDRESS / LOCATION: 3601 Rickenbacker Causeway	DISTRICT: 2
PROJECT TEAM: Vertical	PROJECT CONTRACTED COST:
CATEGORY: Marinas	PROJECT EST. COST: \$ 150,000.00
CLIENT DEPT: 35-CCF-Conf. Conv. & Public Facil.	CURRENT FUNDS: \$ 150,000.00
CLIENT CONTACT: Daniel Newhoff TEL.: (305) 579-6247	FUTURE FUNDS:
DESIGN MANAGER: Nelson Cuadras (CIP) TEL.: 305-416-1254	FUND SHORTFALL:
CONSTR. MANAGER: Nelson Cuadras (CIP) TEL.: 305-416-1254	PROCUREMENT: JOC
EST. DESIGN START: 05/10/09 EST. BID ADV.:	EST. CONSTRUCTION START: 06/10/09
EST. DESIGN END: 05/30/09 EST. AWARD DATE:	EST. CONSTRUCTION END: 09/10/09

PROJECT ESTIMATED AND ACTUAL COSTS	PRODUCTION PHASE (3-DES)		% of Const	Estimated Design	% of Const	Contracted Design
	Prime Consultant: 0000 To be Assigned	CODE				
	1 Outside Consult.-Prime Basic Des. Fee	1.01				
	2 CIP-Design Management	1.04	1.3%	\$ 1,820.00		
	3 Gen. Production Phase Conting.	1.01				
	4					
	PRODUCTION TOTALS			Estimated		Contracted
				\$ 1,820.00		
	CONSTRUCTION PHASE (4-CON)			Estimated Construction by PM	Contracted Construction (Formal Bid, Informal Bid or JOC Method)	
	Prime Contractor: 0000 To be Assigned	CODE				
1 Const. Cost (Prime Contractor)	2	93%	\$ 127,500.00			
2 Const. Contingency Allowance	2	7%	\$ 10,000.00			
3						
CONSTRUCTION TOTALS			Estimated		Contracted	
			\$ 137,500.00			
CONSTRUCTION ADMINISTRATION (8-CEO)		CODE	Estimated CEO	Contracted CEO		
1 Const. Engr. Obs. (CEO) Consult.	3.01					
2 Const. Mgmt by CIP Const. Mgr	3.04	2.9%	\$ 4,000.00			
3 Const. Insp. by CIP Inspector	3.02					
4 JOC Admin.-The Gordian Group	3.03	2.0%	\$ 2,680.00			
5						
CONSTRUCTION ADMINISTRATION TOTALS			Estimated		Contracted	
			\$ 6,680.00			
ADMINISTRATIVE EXPENSES (6-ADM)		CODE	Estimated ADMIN	Contracted ADMIN		
1 CIP Dept. (Gen. Admin. Fees)	4	2.9%	\$ 4,000.00			
2						
ADMINISTRATIVE EXPENSES TOTALS			Estimated		Contracted	
			\$ 4,000.00			
ADDITIONAL PROJECT TASKS		CODE	Estimated TASKS	Contracted TASKS		
1						
ADDITIONAL PROJECT TASKS TOTALS			Estimated		Contracted	
B-33514D PROJECT GRAND TOTAL			Estimated		Contracted	
			\$ 150,000.00			

PROJECT SCOPE	Replacement of the rusted/damaged metal roof deck for 2 boat racks					
	Operating Cost Associated with Project:	YEAR 1	YEAR 2	YEAR 3	YEAR 4	YEAR 5

Notes	
-------	--

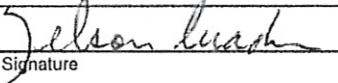
FUND SOURCES	AWARD NAME AND NUMBER		<u>AVAILABLE</u>	<u>FUTURE</u>
	1060 385200-1 2002 Homeland Defense Bonds (Series 1)	326015 Citywide Waterfront Improvements	\$ 150,000.00	
	B-33514D FUND GRAND TOTAL		<u>ACTUAL</u> \$ 150,000.00	<u>PROJECTED</u>

VALIDATION	Initiated by: <u>Nelson Cuadras</u>  Date: <u>5-13-09</u> Project Manager	Signature
	Approved by: <u>N/A</u> Date: _____ Senior Project Manager	Signature
	Reviewed by: <u>David Mendez</u> Date: _____ Assistant Director: Capital Improvements	Signature
	Reviewed by: <u>Yvette Smith</u> Date: _____ CIP Budget Administrator	Signature
	Verified by: <u>Edwige De Crumpe</u> <u>5/13/09</u> Date: _____ Program Controls Staff	Initials  Signature
	Accepted by: <u>Ola Aluko</u> Date: _____ Director: Capital Improvements	Signature
	Approved by: <u>Daniel Newhoff</u> Date: _____ Assistant Director	Signature
ORIGINAL TO: Melanie Whitaker / 8th Floor		Initials <input type="text"/>

Notes	<p>Receipt of PAF by Danette Perez - CIP Public Relations Coordinator</p> <p><u>Project MUST be Presented to the Bond Oversight Board</u> Date Received / Signature or Initials</p>
-------	--

Executed PAF MUST be electronically distributed to the following individuals:
 Director of the Client Department, Yvette Maragh, Edwige De Crumpe, Senior Project Manager and Project Manager.

III. UPDATES:

1. Marine Stadium Marina Improvements

Stephen Bogner, Public Facilities, reported that the project is waiting for the conclusion of the Virginia Key Master Plan in order to move forward with the construction of the new dry storage racks. The new marine item on today's agenda is closely related to this because it is requesting reallocation of \$150,000 of funding that's currently in place for the storage rack restoration to replace a covered rack roof at Marine Stadium Marina. Generally, the project is ready to move forward with design permitting and construction for the dry storage rack roofs. The project will add 87 additional storage racks to the dry storage marina.

2. Saunder's Plot Repairs at City Cemetery

Ed Blanco, Parks & Recreation, reported that the project is complete. The project was initiated almost two years and should have taken six months to complete, but because of severe problems with the contractor, the project took far longer than that. The project was completed March 2009 and came in under budget.

3. Paul S. Walker Park

Ola Aluko, Director, CIP, reported that this project is one of the City's most successful public-public partnerships. The City entered into an agreement with the Miami DDA to fund this project. Roughly 12 or less month's ago, the Department became before the Board and requested \$150,000 of the District 2 quality of life funds to go towards the construction of this park. The before picture of this project was a converted restaurant. The renovation was to convert it back to a park. The DDA put forth the balance of the funds, \$250,000, and the pocket park was created. The project was designed in-house. The landscape architecture was designed by the City Planning Department. The electrical was designed by a CIP engineer, and the DDA designed the civil aspects of the project. The project came in under budget.

4. Roberto Clemente Park New Recreation Building

Orlando Diez, CIP Department, reported that the project is under construction. The contractors and subcontractors have been selected. This week they have been doing infrastructure location, underground utilities, and things like that. The project includes a new one-story building, new landscaping, and new drainage. It appears that the project may come in under budget once it is completed.

5. Kinloch Storm Sewer Improvements - Design Services

Keith Ng, CIP Department, reported that the project is currently in the design phase and the design is 80 percent complete. The design components consist of road and drainage improvements. From the drainage improvement standpoint, the designer for the project has come with the proposal to install underground pipes, increase the number of catch basins, as well as increasing swale trenches, as well as rock trenches. This is in an effort to promote and increase drainage in the area. Right now the design of the drainage improvements is going to be centered heavily with more emphasis in areas where they're mostly hard hit in terms of flooding complaints and flooding situations. In addition to the drainage improvements, road improvements will be implemented once all the drainage improvements are in place. Components of the road improvements include construction of regrading and resodding the swales, milling and resurfacing, replacing damaged sidewalks, replacing curb and gutters, and also increased tree plantings. The consultant has also agreed to look back in their design criteria to also



DEPARTMENT OF CAPITAL IMPROVEMENTS
PROJECT OVERVIEW FORM

ADDITIONAL FUNDING **COMPLETED**

1. DATE: 6/24/08 DISTRICT: 2
 NAME OF PROJECT: Additional Funding for MiaMarina Emergency Repairs Pier # 5
 INITIATING DEPARTMENT/DIVISION: Public Facilities
 INITIATING CONTACT PERSON/CONTACT NUMBER: Carlos Vasquez (305) 416-1206
 C.I.P. DEPARTMENT CONTACT: Ola O. Aluko (305) 416-1280
 RESOLUTION NUMBER: _____ CIP/PROJECT NUMBER: B-30325

2. BUDGETARY INFORMATION: Are funds budgeted? YES NO If yes,
 TOTAL DOLLAR AMOUNT: \$1,675,735 (\$97,530 is Homeland Defense, \$453,205 is Homeland Defense Series 1 Interest, \$125,000 is Sunshine State Financing Commission and \$1,000,000 Homeland Defense was previously approved)

SOURCE OF FUNDS: Citywide Waterfront Improvements and Sunshine State Financing Commission

If grant funded, is there a City match requirement? YES NO
 AMOUNT: _____ EXPIRATION DATE: _____
 Are matching funds budgeted? YES NO Account Code(s): _____
 Estimated Operations and Maintenance Budget _____

3. SCOPE OF PROJECT:

Individuals / Departments who provided input: _____

DESCRIPTION OF PROJECT: This project consists of the remediation of failing concrete structure underneath the commercial dockage area of Pier No. 5. Demolition of approximately 330 L.F. of existing wood decking associated utilities and timber mooring pilings. Construction of approximately 330 L.F. of concrete decking with fiberglass grating, electrical systems, CATV, telephone, and water service for approximately 15 boat slips.

ADA Compliant? YES NO N/A

Approved by Audit Committee? YES NO N/A DATE APPROVED: 6/18/08
 Approved by Bond Oversight Board? YES NO N/A DATE APPROVED: 6/24/08
 Approved by Commission? YES NO N/A DATE APPROVED: _____
 Revisions to Original Scope? YES NO (If YES see Item 5 below)
 Time Approval 6 months 12 months Date for next Oversight Board Update: _____

4. CONCEPTUAL COST ESTIMATE BREAKDOWN

Has a conceptual cost estimate been developed based upon the initial established scope? YES NO If yes,

DESIGN COST: _____

CONSTRUCTION COST: _____

Is conceptual estimate within project budget? YES NO

If not, have additional funds been identified? YES NO

Source(s) of additional funds: _____

Approved by Commission? YES NO N/A DATE APPROVED: _____

Approved by Bond Oversight Board? YES NO N/A DATE APPROVED: _____

5. REVISIONS TO ORIGINAL SCOPE

Individuals / Departments who provided input: _____

Justifications for change: _____

Description of change: _____

Fiscal Impact YES NO HOW MUCH? _____

Have additional funds been identified? YES NO

Source(s) of additional funds: _____

Time impact _____

Approved by Commission? YES NO N/A DATE APPROVED: _____

Approved by Bond Oversight Board? YES NO N/A DATE APPROVED: _____

6. COMMENTS:

APPROVAL: Robert O. Ford DATE: 6/24/08
 BOND OVERSIGHT BOARD

MiaMarina Emergency Repairs Pier No. 5

Project #: B-30325

Scope:

Repairs to an 18 foot lateral concrete joist supporting the commercial dock, one of four per section of Pier 5 at MiaMarina which is deteriorating at an accelerated rate because of natural elements decaying the concrete.

<i>Date:</i>	<i>Allocations</i>	<i>Original Approval</i>	<i>Balance of Allocation</i>	<i>2008 Revised PAF</i>	<i>Additional Approval Being Requested</i>
2005	\$ 491,852	\$ 1,000,000			
2007	\$ 605,678				
2008	<u>\$ 1,097,530</u>			\$ 1,675,735	<u>\$ 97,530</u>

2008 Revised PAF to reflect estimated project cost of \$1,675,735 which includes other non Homeland Defense funding sources

The allocations of \$1,097,530 HD Funds minus original approval of \$1,000,000 =current request of \$97,530

Justification:

- 1- Client (Public Facilities) increased the Scope of Work **
- 2- Existing Dock must be upgraded to current codes and agencies having jurisdiction (DERM-DEP)*
- 3- Cost of living increases over 3 year period. *
- 4- Demolition of existing decking & utilities for 15 boat slips**
- 4- Construction of 330 LF of concrete deck for 15 boat slips **
- 5- Replace of approximately 5 Timber Mooring Piles**
- 6- Replace of approximately 330 LF of Dock concrete deck w/ fiberglass grating
- 7- Additional ADA requirements for Access, etc. must be complied with *
- 8- Installation of Shore Power Elect. Syst. Including CATV & Telephone**
- 9- Installation of Domestic Water Services**
- 9- Additional contingency **
- 10- Increase management fees **

* Construction

** Design & Construction

CITY OF MIAMI, FLORIDA
INTER-OFFICE MEMORANDUM

TO: Ola Aluko, Director
Capital Improvements Department

DATE: May6, 2008 FILE: B-30325

SUBJECT: PAF for MiaMarina
Emergency Repairs Pier # 5

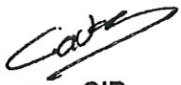
FROM: Carlos Vasquez 
Construction Manager, CIP

Description:

The attached Project Analysis Form, (PAF) are to approve funds and scope of work for the above referenced project.

Justification:

Based on a structural study performed by Coastal Systems International, Inc., to address Owner's concerns related to the safety and stability of the structure, it was recommended to repair the commercial dockage area.

Scope of Work:

Remediation of failing concrete structure underneath the commercial dockage area of Pier No 5. Demolition of approximately 330 L.F. of existing wood decking associated utilities and timber mooring pilings. Construction of approximately 330 L.F. of concrete decking with fiberglass grating, electrical systems, CATV, telephone, and water service for approximately 15 boat slips.

Funding:

The total cost to cover the design, production, construction, construction administration phases has been estimated at \$ 1,675,735.00. The project funding is as follows:

385200-1	2002 Homeland Defense Bonds series 1	326015	\$	415,027.00
385200-1	2002 Homeland Defense Bonds series 1	326015	\$	76,825.00
385200-2	2002 Homeland Defense Bonds series 1	326015	\$	605,678.00
385200-8	Homeland Defense Bonds series 1	326015	\$	453,205.00
888960	Sunshine State Financing Commission	326015	\$	125,000.00
			\$	<u>1,675,735.00</u>

It is recommended to approve the attached PAF to proceed with the required work

Cc: David J. Mendez, P.E Assistant Director Capital Improvements
Gary Fabrikant, Assistant Director Capital Improvements
Yvette Maragh, CIP Administrator Capital Improvements
Job File



PROJECT ANALYSIS FORM

Capital Improvements & Transportation

CIP NON-CIP

Date Prepared:	6-May-2008
VERSION	ORIGINAL

PROGRAM 325-Public Facilities AREA 2-Recreation & Culture





PROJECT NAME: Miamarina Emergency Pier Repairs		PROJECT NO: B-30325
ADDRESS / LOCATION: 401 Biscayne Blvd. at Bayside.		DISTRICT: 2
PROJECT TEAM: Vertical	PROJECT CONTRACTED COST: \$ 96,825.00	
CATEGORY: Marinas	PROJECT EST. COST: \$ 1,675,735.00	
CLIENT DEPT: 35-CCF-Conf. Conv. & Public Facil.	CURRENT FUNDS: \$ 1,675,735.00	
CLIENT CONTACT: Daniel Newhoff	TEL.: (305) 579-6247	FUTURE FUNDS:
DESIGN MANAGER: Steve Bogner	TEL.: 305-579-6950	FUND SHORTFALL:
CONSTR. MANAGER: Carlos Vasquez (CIP)	TEL.: 305-416-1206	PROCUREMENT: Conventional
EST. DESIGN START: 07/15/05	EST. BID ADV.: 09/20/07	EST. CONSTRUCTION START: 11/20/07
EST. DESIGN END: 05/15/07	EST. AWARD DATE:	EST. CONSTRUCTION END: 10/15/08

PROJECT ESTIMATED AND ACTUAL COSTS	PRODUCTION PHASE (3-DES)		% of Const	Estimated Design	% of Const	Contracted Design
	Prime Consultant: <u>298 Coastal Systems, International</u>	CODE				
	1 Outside Consultant - Prime Basic Design Fee	1.01	5.3%	\$ 76,825.00		
	2 Outside Consultant - Additional Design Services	1.01	0.7%	\$ 10,000.00		
	3 CIP - Production Management	1.04	1.4%	\$ 20,000.00		
	4 CIP In-House - Basic Design Fee	1.02				
	5					
	PRODUCTION TOTALS			Estimated	Contracted	
				\$ 106,825.00	\$	80,325.00
	CONSTRUCTION PHASE (4-CON)			Estimated Construction by PM	Contracted Construction (Formal Bid, Informal Bid or JOC Method)	
Prime Contractor: <u>0000 To be Assigned</u>	CODE					
1 Construction Cost (Prime Contractor)	2	90%	\$ 1,296,000.00			
2 Construction Contingency Allowance	2	10%	\$ 150,000.00			
3						
CONSTRUCTION TOTALS			Estimated	Contracted		
			\$ 1,446,000.00	\$	6,000.00	
CONSTRUCTION ADMINISTRATION (8-CEO)			Estimated CEO	Contracted CEO		
1 Construction Engineering Observation CIP/Transportation	3.02	4.5%	\$ 65,070.00			
2						
CONSTRUCTION ADMINISTRATION TOTALS			Estimated	Contracted		
			\$ 65,070.00			
ADMINISTRATIVE EXPENSES (6-ADM)			Estimated ADMIN	Contracted ADMIN		
1 CIP Department (Mgmt./Budget/Procurement/Comm.)	4	4.0%	\$ 57,840.00			
2						
ADMINISTRATIVE EXPENSES TOTALS			Estimated	Contracted		
			\$ 57,840.00	\$	10,500.00	
ADDITIONAL PROJECT TASKS			Estimated TASKS	Contracted TASKS		
1						
ADDITIONAL PROJECT TASKS TOTALS			Estimated	Contracted		
B-30325 PROJECT GRAND TOTAL			Estimated	Contracted		
			\$ 1,675,735.00	\$	96,825.00	

PROJECT SCOPE	Remediation of failing concrete underneath the commercial dockage area of Pier 5 at Miamarina. <input type="checkbox"/>					
	Operating Cost Associated with Project:	YEAR 1	YEAR 2	YEAR 3	YEAR 4	YEAR 5

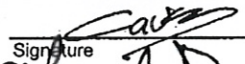
Notes	
--------------	--

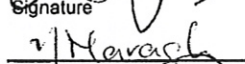
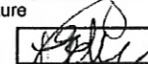
FUND SOURCES	AWARD NAME AND NUMBER	AVAILABLE	FUTURE
		385200-1 2002 Homeland Defense Bonds (Serit 326015 Citywide Waterfront Improv	\$ 415,027.00
1060	385200-1 2002 Homeland Defense Bonds (Serit 326015 Citywide Waterfront Improv	\$ 76,825.00	
	385200-2 2002 Homeland Defense Bonds (Serit 326015 Citywide Waterfront Improv	\$ 605,678.00	
	385200-8 Homeland Defense Series 1 Interest F 326015 Citywide Waterfront Improv	\$ 453,205.00	
	888960 Sunshine State Financing Commission 326015 Citywide Waterfront Improv	\$ 125,000.00	
	B-30325 FUND GRAND TOTAL	ACTUAL \$ 1,675,735.00	PROJECTED

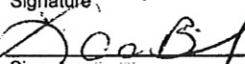
VALIDATION	Initiated by: <u>Carlos Vasquez</u> Project Manager		Date: <u>5/06/08</u>
	Approved by: <u>Marcel Douge</u> Senior Project Manager		Date: <u>5/7/08</u>
	Reviewed by: <u>David Mendez</u> Assistant Director: Capital Improvements		Date: <u>5/14/08</u>
	Reviewed by: <u>Yvette Maragh</u> CIP Budget Administrator		Date: <u>5/6/08</u>
	Verified by: <u>Edwige De Crumpe / Program Controls Staff</u>	Initials: 	
	Accepted by: <u>Ola Aluko</u> Director: Capital Improvements		Date: <u>5/15/08</u>
	Approved by: <u>Laura Billberry</u> Director: Public Facilities		Date: <u>5/30/08</u>
	ORIGINAL TO: <u>Melanie Whitaker / 10th Floor South Conference Room</u>	Initials: <input type="text"/>	

Notes	<p>Receipt of PAF by Danette Perez - CIP Public Relations Coordinator</p> <p><u>Project MUST be Presented to the Bond Oversight Board</u></p> <p>Date Received: <u>5/21/08</u> Signature or Initials: <u>Marcia Lopez</u></p>
--------------	---

Executed PAF MUST be electronically distributed to the following individuals:
 Director of the Client Department, Yvette Maragh, Edwige De Crumpe, Senior Project Manager and Project Manager.

- Additional Services for Antonio Maceo New Community Building

NAME OF PROJECT: Additional Services for Antonio Maceo New Community Building
TOTAL DOLLAR AMOUNT: \$118,833 (\$90,124 is Homeland Defense and \$28,709 is Impact Fees)
SOURCE OF FUNDS: HDNI/Neighborhood Park Improvements and Impact Fees (Flagami Residential Park Renovations)
DESCRIPTION OF PROJECT: This project consists of additional work to the following work items: site work, irrigation, storm drainage, site utilities, sidewalks and pavers, casework, hardware to include ADA access, metal support assemblies, gypsum board, and ceramic tile, acoustical ceilings, special coatings, hurricane protection, office furniture, plumbing HVAC and electrical.

HD/NIB MOTION 08-22

A MOTION TO FUND THE ADDITIONAL SERVICES FOR ANTONIO MACEO NEW COMMUNITY BUILDING.

MOVED: K. Apfel
 SECONDED: L. Cabrera
 ABSENT: M. Cruz, R. Lambert, G. Reshefsky, J. Reyes, J. Solares, H. Willis

Note for the Record: Motion passed by unanimous vote of all Board Members present.

III. OLD BUSINESS:

- Additional Funding for Miamarina Emergency Repairs Pier No. 5

NAME OF PROJECT: Additional Funding for MiaMarina Emergency Repairs Pier # 5
TOTAL DOLLAR AMOUNT: \$1,675,735 (\$97,530 is Homeland Defense, \$453,205 is Homeland Defense Series 1 Interest, \$125,000 is Sunshine State Financing Commission and \$1,000,000 Homeland Defense was previously approved)
SOURCE OF FUNDS: Citywide Waterfront Improvements and Sunshine State Financing Commission
DESCRIPTION OF PROJECT: This project consists of the remediation of failing concrete structure underneath the commercial dockage area of Pier No. 5. Demolition of approximately 330 L.F. of existing wood decking associated utilities and timber mooring pilings. Construction of approximately 330 L.F. of concrete decking with fiberglass grating, electrical systems, CATV, telephone, and water service for approximately 15 boat slips.

HD/NIB MOTION 08-23

A MOTION TO FUND THE ADDITIONAL FUNDING FOR MIAMARINA EMERGENCY REPAIRS PIER NO. 5.

MOVED: L. Cabrera
 SECONDED: K. Apfel
 ABSENT: M. Cruz, R. Lambert, G. Reshefsky, J. Reyes, J. Solares, H. Willis

Note for the Record: Motion passed by unanimous vote of all Board Members present.

2. Additional Funding for MiaMarina Emergency Repair Pier #5

Eileen Broton reported that the project is another revenue generator for the City. They're requesting \$97,000 of the original approved amount. The project will replace damaged pre-cast concrete stringers, replacement of wood decks with fiberglass and replacing utility services. The contract has already been awarded and construction is anticipated to begin next month with a targeted completion date in late September of '09.

3. Pierce Lance HAZMAT Vehicle for the Fire Department

AND

4. Defense and Security Equipment Acquisition

Eileen Broton reported that the item was purchased and put into service in May 2008, and the Board requested information on how often it is used. Item 4, Defense and Security Equipment Acquisition, includes the scuba gear, which will be ordered in May of 2009, and also the training center. The standards for the training center are constantly changing, and the Fire Department is looking for the proper site and trying to see the latest requirements, so this may be on hold until possibly the last quarter of 2009, and we have asked the Fire Department to provide more information for us.

Joe Fernandez, assistant fire chief with the Department of Fire-Rescue, reported that he replaced Chief Duran on the project. The Pierce Lance truck was put in service in May 2008. It was purchased at budget, \$564,577. I do not have an exact number of alarm numbers to date, but I will tell you that this truck does not go out on every single call, kind of like you see the first line pumpers and aerial and rescue trucks. It's a specialized piece of equipment and it goes on certain types of calls when the dispatches come in, whether there's chemical situations, even structural events, and a variety of other specialized scenarios that we might have to respond to. As you know, the previous vehicle was beyond its service life, and the truck really has been a great asset, especially in the midst of everything that we find ourselves under these days, having a vehicle to move around the necessary equipment is very important. So we appreciate your support on it. And if you would like the number of calls that it has responded to since May 29, I can send that to the staff, and they can give it to you via e-mail. Regarding the scuba gear, the equipment here will allow for ten full sets of scuba gear, plus backup equipment to make sure we always have ten sets at the ready to do the services that we aim to do with this equipment. It will be, again, a citywide asset that will be located on the marine unit, and it's of great value, as I said, both for the citizens or visitors that may require services of this type, and for the firefighters themselves, to have the best gear possible to do the job they need to do. I did make a typo here. It was not the staff's fault. If you add the two items, it should come to 899. You see this says 32 as the estimated cost and it's actually 34. So if you add the 34 to the other total, you do get to the 899, but that was my error. This is currently slightly delayed due to a bid issue that the Purchasing Department wanted to do a split bid, I believe. I'm still transitioning with Chief Duran, but it's slightly delayed because of a process in the Purchasing Department, but we do expect to issue a purchase order by March '09 and delivery should be immediately after. This is all equipment, materials that are all readily available. Regarding the training tower, I gave you a sampling here of some photos from the various vendors that might be the actual suppliers of this equipment, and this type of training is not

5. MiaMarina Emergency Repair Pier No. 5

Eileen Broton stated that the project is under construction. Demolition was completed, but issues were found that compromised the structure and it was recommended that there needed to be more demolition.

Carlos Vasquez, CIP Department, reported that the project is currently under construction. The demolition was finished yesterday. In doing so, unforeseen conditions were discovered that are compromising the structure of the piles. A decision was made to remove the piles because they're in really bad condition. The design-build of the piles will be continued because drawings need to be completed and approved by the engineers and sent to the Building Department for approval. The project is still on schedule even though additional scope of work has been added. The project expected completion date is by the end of 2009 or late January 2010.

IV. CHAIRPERSON'S OPEN AGENDA:

V. ADDITIONAL ITEMS:



DEPARTMENT OF CAPITAL IMPROVEMENTS
PROJECT OVERVIEW FORM

PREVIOUSLY APPROVED

1. DATE: 6/28/05 DISTRICT: 2
NAME OF PROJECT: MIAMARINA PIER 5 DOCK EMERGENCY REPAIRS
INITIATING DEPARTMENT/DIVISION: Public Facilities
INITIATING CONTACT PERSON/CONTACT NUMBER: Daniel Newhoff (305) 579-6341
C.I.P. DEPARTMENT CONTACT:
RESOLUTION NUMBER: _____ CIP/PROJECT NUMBER: 326015
ADDITIONAL PROJECT NUMBER: _____
(IF APPLICABLE)

2. BUDGETARY INFORMATION: Are funds budgeted? YES NO If yes,
TOTAL DOLLAR AMOUNT: \$1,000,000 (10 Million total Bond allocation)

SOURCE OF FUNDS: HDNI - Citywide Waterfront Improvements
ACCOUNT CODE(S): CIP # 326015
If grant funded, is there a City match requirement? YES NO
AMOUNT: _____ EXPIRATION DATE: _____
Are matching funds Budgeted? YES NO Account Code(s): _____
Estimated Operations and Maintenance Budget _____

3. SCOPE OF PROJECT:
Individuals / Departments who provided input: Daniel Newhoff / Public Facilities
DESCRIPTION OF PROJECT: Scope includes the repairs to an 18 foot lateral concrete joist supporting the commercial dock, one of four per section of Pier 5 at MiaMarina which is deteriorating at an accelerated rate because of natural elements decaying the concrete.
ADA Compliant? YES NO N/A

Approved by Audit Committee? YES NO N/A DATE APPROVED: 6/8/05
Approved by Bond Oversight Board? YES NO N/A DATE APPROVED: 6/28/05
Approved by Commission? YES NO N/A DATE APPROVED: _____
Revisions to Original Scope? YES NO (If YES see Item 5 below)
Time Approval 6 months 12 months Date for next Oversight Board Update: _____

4. CONCEPTUAL COST ESTIMATE BREAKDOWN
Has a conceptual cost estimate been developed based upon the initial established scope? YES NO If yes,
DESIGN COST: _____
CONSTRUCTION COST: _____
Is conceptual estimate within project budget? YES NO
If not, have additional funds been identified? YES NO
Source(s) of additional funds: _____

Approved by Commission? YES NO N/A DATE APPROVED: _____
Approved by Bond Oversight Board? YES NO N/A DATE APPROVED: _____

5. REVISIONS TO ORIGINAL SCOPE
Individuals / Departments who provided input: _____
Justifications for change: _____
Description of change: _____

Fiscal Impact YES NO HOW MUCH? _____
Have additional funds been identified? YES NO
Source(s) of additional funds: _____

Time impact
Approved by Commission? YES NO N/A DATE APPROVED: _____
Approved by Bond Oversight Board? YES NO N/A DATE APPROVED: _____

6. COMMENTS: Estimated 1 Million for improvements based on staff recommendations. Exact amount will come back before board. Coconut Grove Dock Master Plan funded 1st series, but will be swapped to 2nd series because of Coconut Grove Master plan.

APPROVAL:  DATE: 6/28/05
BOND OVERSIGHT BOARD

Enclosures: Back-Up Materials YES NO



AGENDA ITEM SUMMARY FORM

FILE ID: _____

Date: 6/3/2005

Requesting Department: CIP

Commission Meeting Date: 6/9/2005

District Impacted: _____

Type: Resolution Ordinance Emergency Ordinance Discussion Item

Other _____

Subject: Emergency Ordinance revising appropriations and allocations for capital projects.

Purpose of Item:

Revising appropriations and allocations for capital improvement projects scheduled to begin in FY2004-2005, specifically for time-sensitive Homeland Defense/Neighborhood Improvement Bond projects, appropriating new revenue and adjusting appropriations per recent Community Development Block Grant legislation.

Background Information:

The City of Miami Capital Improvement Projects have been reviewed and, in some cases, ongoing capital projects have been revised and respective appropriations increased or decreased in their totals, more specifically to expedite time-sensitive projects under the Homeland Defense/Neighborhood Improvement Bond Program. Further, on May 21, 2005, a lateral concrete joist supporting the dock at Pier 5 at Miamarina broke off, indicating deterioration of the pier structure. Reallocation of first series Homeland Defense/Neighborhood Improvement Bonds is recommended for funding the required structural remediation. This legislation also includes an adjustment to the current CDBG appropriation for capital street projects per a resolution approved by the City Commission on May 26, 2005.

Budget Impact Analysis

YES Is this item related to revenue?

NO Is this item an expenditure? If so, please identify funding source below.

General Account No: _____

Special Revenue Account No: _____

CIP Project No: _____

_____ Is this item funded by Homeland Defense/Neighborhood Improvement Bonds?

Start Up Capital Cost: _____

Maintenance Cost: _____

Total Fiscal Impact: _____

C.I.P. APPROVALS
[Signature] 6/6/05
Signature Date

Final Approvals
(SIGN AND DATE)

CIP *[Signature]*
If using or receiving capital funds
Grants

Budget *[Signature]* 6/6/05

Risk Management _____

Purchasing _____

Dept. Director *[Signature]*

Chief _____

City Manager *[Signature]*

..Title

AN EMERGENCY ORDINANCE, WITH ATTACHMENTS, OF THE MIAMI CITY COMMISSION, AMENDING ORDINANCE NO. 12622, AS AMENDED, ADOPTED DECEMBER 9, 2004, TO REVISE CURRENT HOMELAND DEFENSE/NEIGHBORHOOD IMPROVEMENT BOND APPROPRIATIONS AMONG APPROVED PROJECTS, APPROPRIATE NEW REVENUE AND ADJUST COMMUNITY DEVELOPMENT BLOCK GRANT APPROPRIATIONS; CONTAINING A REPEALER PROVISION, A SEVERABILITY CLAUSE AND PROVIDING FOR AN EFFECTIVE DATE.

WHEREAS, on December 9, 2004 the City Commission approved Ordinance No. 12622 establishing appropriations for Capital Projects for fiscal year 2004-2005; and

WHEREAS, the City of Miami Capital Improvement Projects have been reviewed and, in some cases, ongoing capital projects have been revised and respective appropriations increased or decreased in their totals ; and

WHEREAS, it is necessary to reallocate first series Homeland Defense/Neighborhood Improvement Bond funds for B-30305 "Miamarina Emergency Pier Repairs" to address a life/safety condition resulting from failing concrete underneath the commercial dockage area of Pier 5 at Miamarina; and

WHEREAS, this Ordinance is declared to be an emergency measure on the grounds it is necessary to safeguard the health, safety, welfare and convenience of the City, specifically to ensure that funding is in place to remediate the structural condition at the Miamarina pier;

NOW, THEREFORE, BE IT RESOLVED BY THE COMMISSION OF THE CITY OF MIAMI, FLORIDA:

Section 1. The recitals and findings found in the preamble of this resolution are adopted by reference and incorporated as if fully set forth in this Section.

Section 2. Ordinance No. 12622, as amended, adopted December 9, 2004, the Capital Projects Appropriations Ordinance, is amended in the following particulars: {1}

"Ordinance No. 12622

Section 1. The herein appropriations are hereby made for implementation of all municipal capital improvements of the City of Miami, including new capital improvement projects scheduled to begin during Fiscal Year 2005. The herein appropriations which are hereby designated by reference to descriptive project title and number also include appropriations for previously approved scheduled projects as well as reappropriations of prior funds. The sources of revenues to support the herein appropriations are hereby identified by fund and project in ten Capital Funds, as follows:

II. NEW BUSINESS:

A. AUDIT COMMITTEE REPORT:

- FPL Easement for Underground Utilities Services at Jose Marti Park.

TOTAL DOLLAR AMOUNT: \$5,000 (1.35 million allocated; estimated current balance is \$29,172)
SOURCE OF FUNDS: HDNI – Neighborhood Park Improvements
DESCRIPTION OF PROJECT: Scope includes the cost of installation of a new pad mounted transformer at the newly completed Jose Marti Park-Recreational Building in order to provide electrical power to the building by Florida Power and Light Company (FPL).

HD/NIB MOTION 05-61

A MOTION TO APPROVE THE AUDIT COMMITTEE'S RECOMMENDATION TO FUND THE FPL EASEMENT FOR UNDERGROUND UTILITIES SERVICES AT JOSE MARTI PARK.

MOVED: M. Reyes
SECONDED: M. Cruz
ABSENT: L. Cabrera, R. Cayard, L. De Rosa, J. Manowitz, J. Reyes

Note for the Record: Motion passed by unanimous vote of all Board Members present.

- Emergency Dock Repairs at Miamarina Pier 5.

TOTAL DOLLAR AMOUNT: \$1,000,000 (10 Million total Bond allocation)
SOURCE OF FUNDS: HDNI – Citywide Waterfront Improvements
DESCRIPTION OF PROJECT: Scope includes the repairs to an 18 foot lateral concrete joist supporting the commercial dock, one of four per section of Pier 5 at MiaMarina which is deteriorating at an accelerated rate because of natural elements decaying the concrete.

HD/NIB MOTION 05-62

A MOTION TO APPROVE THE AUDIT COMMITTEE'S RECOMMENDATION TO FUND THE EMERGENCY DOCK REPAIRS AT MIAMARINA PIER 5.

MOVED: M. Reyes
SECONDED: M. Cruz
ABSENT: L. Cabrera, R. Cayard, L. De Rosa, J. Manowitz, J. Reyes

Note for the Record: Motion passed by unanimous vote of all Board Members present.

fall of 2006. The contractor has begun construction. The first progress meeting for the project will be on Thursday. There have been a couple of areas of the project that need to be addressed, but they are expected to be within the allocated construction costs. The project is still on budget.

4. Miamarina Pier 5 Dock Emergency Repairs

Juan Ordonez, CIP Department, reported that the project is 90 percent complete. The structural portion of the project is 100 percent complete. There is about 85 percent completion on the electrical and the plumbing. The project is expected to be completed for the final plans to be submitted for permitting at the end of March. Construction can start in May, and the construction process can be finished by the end of the year. The design of the project is still within budget.

5. Armbrister Recreation Building Improvements – Design Services

Sandra Vega, CIP Department, reported that the design is 100 percent complete.

6. Armbrister Recreation Building Improvements

Sandra Vega, CIP Department, reported that the improvements are computer stations, ADA compliance in the restrooms, the main building entrance, and new lighting fixtures. The construction document permits and bidding phases are 100 percent complete, as well. The JOC pricing is 100 percent complete. The project is on budget. The construction estimated start date is about the second week in March, and the construction estimated completion date is October 2006.

7. Simpson Park Wood Trail

Sandra Vega, CIP Department, reported that the project includes the construction of approximately 700 linear feet of boardwalk connecting the existing community building to the newly refurbished pond. At this moment, the JOC pricing on the project is in progress. The DERM permit is also in progress. The Department needs to work with DERM for the final approval of the design. The construction estimated start date is November 2006. The project may start earlier depending on DERM's response to the new design, as well as how well the community responds to the new design.

Mary Conway, Director, CIP & Transportation, reported that the community has already provided input as part of the process, and there has been extensive coordination with DERM as a result of that because of the hardwood hammock that exists at this site and the sensitivity to making sure that the trail is as minimally disruptive to that as possible. Once the issues are resolved with DERM, the Department will go back and coordinate with the public further so they know what the final decisions are.

Jason Manowitz questioned whether additional funding could be sought to use a different material other than wood on the project. Mary Conway stated that funding could not be through the Bond, but the Department could explore, with the Parks Department, the possibility of looking at impact fee dollars or another revenue source. It is very, very much more expensive from a capital standpoint to use a recycled material than to use the wood.

8. Athalie Range Park – Mini Stadium Complex

Marcel Douge, CIP Department, reported that the project consists of reconfiguring the fields into football and soccer fields, new bleachers, a storage area, ADA compliant walkways and irrigation. The project is approximately 75 percent designed and design completion is scheduled for completion in January 2007.

9. Athalie Range Park Swimming Pool Improvements

Ed Herald, CIP Department, reported that the project has encountered a number of problems. There are air voids under the swimming pool. When some of the pipes were exposed, decrepit pipes were encountered and those changes are being addressed. The project will go through some redesigning to address some of the repairs that are going to be needed. In order to maintain the current budget, the Department is looking at swapping out some of the existing scope of work so that the budget can be maintained. The roof is now included as part of the scope of work, and the Department feels that the roof tile can be salvaged, so this is one of those projects that unearthed a number of problems.

10. MiaMarina Pier 5 Dock Emergency Repairs

Marcel Douge, CIP Department, reported that the project is in design. The scope of work includes replacement of approximately 310 linear feet of decking, fiberglass grating and piling. The project has obtained preliminary DERM approval and is now being reviewed by the Building Department for final approval. The design is approximately 95 percent complete, and completion is expected in November 2006. The project is currently in budget.

Stephen Bogner, Public Facilities, stated that the scope of work includes the removal of the decking of approximately 20 slips at the commercial docks at MiaMarina that have become structurally unstable. The permitting is close to final approval. The slips are currently being used. However, a couple of vessels were relocated out of two slips where the problems were significant. The design, engineering, and permitting work is being done by Coastal Systems International.

11. Douglas Park Recreation Building Renovations- Design Services

Marcel Douge, CIP Department, reported that the design plans are 60 percent completed, and design completion is expected in January 2007.

12. Antonio Maceo Park New Community Building

Ed Herald, CIP Department, reported that the project is under construction. It is a 5,300 square foot building. All of the foundations are in place; concrete block is in place, and trusses are being built. The project is on schedule and on budget.

13. Kinloch Park Community Recreation Building

Ed Herald, CIP Department, reported that the project scope includes approximately 1,500 square feet of building addition. The project is 90 percent complete and finishing touches are being put on the interior finishes and finishing up the miscellaneous site work. Substantial completion is expected next month.

Note for the Record: Motion passed by unanimous vote of all Board Members present.

3. Lummus Park –Police Stables

Ola O. Aluko, CIP Director, requested that the item be pulled and brought back at a later date, if necessary. He stated that he will determine if the project change order will be funded with HD funds. If not, then the project will not be brought back before the Board.

UPDATES:

1. Dinner Key Mooring Anchorage Field Project

Stephen Bogner, Public Facilities, reported that the project entails the construction and installation of 225 moorings in the waters just offshore of Dinner Key Marina. The facility will be operated and managed by the City of Miami's Department of Public Facilities Marinas Division. Currently, engineering and permitting consultants in CIP are preparing construction documents for bid. The consultants are working to provide CIP with all of the information required to finalize 100 percent construction plans. The Department is working with the regulatory agencies on minor permit modifications and securing final Miami-Dade County DERM and City construction permits. No major problems are anticipated. City staff recently traveled to the municipally managed Boot Key Harbor Marina in Marathon, Florida to meet with their facility's staff and discuss startup and operational issues and tour the mooring field. Next, the Department hopes to finalize construction plans for bid and bid the project out by March 1, 2008. Construction is anticipated to begin by June 1, 2008. Construction completion is estimated for July 31, 2008, with the mooring field opening by September 1, 2008.

2. Fuel Dock At Dinner Key Marina

Ola O. Aluko, CIP Director, reported that the project is pretty much stalled mainly because of the waterfront master plan and other environmental issues that need to be ironed out. The design has been completed and the design drawings are being shelved for now. Once the Sasaki master plan is completed, the current design will be examined to determine if it is in conformance with the new master plan. If so, the project will be brought back and moved forward; if not, the necessary revisions will be made.

3. MiaMarina Pier 5 Dock Emergency Repairs

Stephen Bogner, Public Facilities, reported that the project is still an emergency after two-plus years. Bid documents are being prepared by consultants in the CIP Department to put the project out to bid. All of the regulatory agency permit approvals have been obtained. CIP is currently working on finalizing the City permit approvals. Next, construction plans will be finalized for bid and the project will be bid out by February 2008. Construction is anticipated to begin around April 1, 2008, with a completion date estimated for June 15, 2008.

4. Juan Pablo Duarte Park-Water Playground

Ed Blanco, Parks & Recreation Department, reported that a purchase order was issued May 2007, and the project is still in the design and permitting phase. There were concerns from the contractor this month that the soil at the park next to the recreation building is soft and they may have to excavate and put in new fill in order to complete the project.

5. West End Park-Water Playground



DEPARTMENT OF CAPITAL IMPROVEMENTS
PROJECT OVERVIEW FORM

COMPLETED

1. DATE: 7/28/09 DISTRICT: 2
 NAME OF PROJECT: MERRIE CHRISTMAS PARK NEW SWINGS
 INITIATING DEPARTMENT/DIVISION: Parks & Recreation
 INITIATING CONTACT PERSON/CONTACT NUMBER: Ed Blanco (305) 416-1253
 C.I.P. DEPARTMENT CONTACT: _____
 RESOLUTION NUMBER: _____ CIP/PROJECT NUMBER: B-75864

2. BUDGETARY INFORMATION: Are funds budgeted? YES NO If yes,
 TOTAL DOLLAR AMOUNT: \$60,000 (\$50,000 is Homeland Defense)

SOURCE OF FUNDS: Neighborhood Park Improvements
 ACCOUNT CODE(S): 3331419

If grant funded, is there a City match requirement? YES NO
 AMOUNT: _____ EXPIRATION DATE: _____
 Are matching funds budgeted? YES NO Account Code(s): _____
 Estimated Operations and Maintenance Budget _____

3. SCOPE OF PROJECT:

Individuals / Departments who provided input: _____

DESCRIPTION OF PROJECT: Installation of a new swing set on a rubber surface.

ADA Compliant? YES NO N/A

Approved by Audit Committee? YES NO N/A DATE APPROVED: 7/21/09
 Approved by Bond Oversight Board? YES NO N/A DATE APPROVED: 7/28/09
 Approved by Commission? YES NO N/A DATE APPROVED: _____
 Revision(s) to Original Scope? YES NO (If YES see Item 5 below)
 Time Approval 6 months 12 months Date for next Oversight Board Update: _____

4. CONCEPTUAL COST ESTIMATE BREAKDOWN

Has a conceptual cost estimate been developed based upon the initial established scope? YES NO If yes,
 DESIGN COST: _____
 CONSTRUCTION COST: _____
 Is conceptual estimate within project budget? YES NO
 If not, have additional funds been identified? YES NO
 Source(s) of additional funds: _____

Approved by Commission? YES NO N/A DATE APPROVED: _____
 Approved by Bond Oversight Board? YES NO N/A DATE APPROVED: _____

5. REVISIONS TO ORIGINAL SCOPE

Individuals / Departments who provided input: _____

Justifications for change: _____

Description of change: _____

Fiscal Impact YES NO HOW MUCH? _____
 Have additional funds been identified? YES NO
 Source(s) of additional funds: _____

Time impact _____
 Approved by Commission? YES NO N/A DATE APPROVED: _____
 Approved by Bond Oversight Board? YES NO N/A DATE APPROVED: _____

6. COMMENTS: _____

APPROVAL: 
 BOND OVERSIGHT BOARD

DATE: 7/28/09

Enclosures: Back-Up Materials YES NO

HOMELAND DEFENSE / NEIGHBORHOOD IMPROVEMENT BOND FUNDS

JULY 2009 DEPARTMENT OF PARKS AND RECREATION PROPOSED PROJECT FUNDING

<u>PARK</u>	<u>PROJECT</u>	<u>B-No.</u>	<u>\$ REQ.</u>	<u>BUDGET</u>	<u>ORIG. SCOPE</u>	<u>INITIATED BY</u>
Merrie Christmas Le Jeune and Barbarosa Street	New Swings	75864	\$50,000	\$60,000	Site Improvements	Park Staff

Total Requested from Bond Funds: \$50,000

I. APPROVAL OF THE MINUTES FOR THE MEETING OF JUNE 23, 2009.

HD/NIB MOTION 09-27

A MOTION TO APPROVE THE MINUTES OF THE MEETING OF JUNE 23, 2009.

MOVED: P. Perez-Cisneros
SECONDED: M. Cruz
ABSENT: H. Arza, L. De Rosa, R. Flanders, K. Hancock-Apfel, R. Lambert, C. Matos,
J. Solares

Note for the Record: Motion passed by unanimous vote of all Board Members present.

II. NEW ITEMS:

1. Merrie Christmas Park New Swings

NAME OF PROJECT: <u>MERRIE CHRISTMAS PARK NEW SWINGS</u>
TOTAL DOLLAR AMOUNT: <u>\$60,000 (\$50,000 is Homeland Defense)</u>
SOURCE OF FUNDS: <u>Neighborhood Park Improvements</u>
ACCOUNT CODE(S): <u>3331419</u>
DESCRIPTION OF PROJECT: <u>Installation of a new swing set on a rubber surface.</u>

HD/NIB MOTION 09-28

A MOTION TO FUND MERRIE CHRISTMAS PARK NEW SWINGS.

MOVED: M. Cruz
SECONDED: P. Perez-Cisneros
ABSENT: H. Arza, L. De Rosa, R. Flanders, K. Hancock-Apfel, R. Lambert, C. Matos,
J. Solares

Note for the Record: Motion passed by unanimous vote of all Board Members present.

2. Police Department Property Unit Outdoor Storage

NAME OF PROJECT: <u>POLICE DEPARTMENT PROPERTY UNIT OUTDOOR STORAGE</u>
TOTAL DOLLAR AMOUNT: <u>\$870,928 (\$116,235.00 is Homeland Defense)</u>
SOURCE OF FUNDS: <u>Police Homeland Defense Preparedness</u>
ACCOUNT CODE(S): <u>312048</u>
DESCRIPTION OF PROJECT: <u>Design and construction of an outdoor storage building for the MPD Property Unit Division. The project consists of a new 600 s.f. 16' ht. air conditioned warehouse type building with heavy duty steel storage shelves. Additional work as of September: add a 750 s.f. second floor office space above the new storage building (under construction). This new work will require design modification to the existing storage building plans and permit revisions.</u>

HD/NIB MOTION 09-29

A MOTION TO FUND POLICE DEPARTMENT PROPERTY UNIT OUTDOOR STORAGE.

MOVED: M. Cruz
SECONDED: L. Cabrera
ABSENT: H. Arza, L. De Rosa, R. Flanders, K. Hancock-Apfel, R. Lambert, C. Matos,
J. Solares

Note for the Record: Motion passed by unanimous vote of all Board Members present.



DEPARTMENT OF CAPITAL IMPROVEMENTS
PROJECT OVERVIEW FORM

UPDATE

1. DATE: 7/28/09 DISTRICT: Citywide
 NAME OF PROJECT: POLICE DEPARTMENT PROPERTY UNIT OUTDOOR STORAGE
 INITIATING DEPARTMENT/DIVISION: Miami Police Department
 INITIATING CONTACT PERSON/CONTACT NUMBER: Orlando Diez (305) 416-1047
 C.I.P. DEPARTMENT CONTACT: _____
 RESOLUTION NUMBER: _____ CIP/PROJECT NUMBER: B-30373A

2. BUDGETARY INFORMATION: Are funds budgeted? YES NO If yes,
 TOTAL DOLLAR AMOUNT: \$870,928 (\$116,235.00 is Homeland Defense)

SOURCE OF FUNDS: Police Homeland Defense Preparedness
 ACCOUNT CODE(S): 312048

If grant funded, is there a City match requirement? YES NO
 AMOUNT: _____ EXPIRATION DATE: _____
 Are matching funds budgeted? YES NO Account Code(s): _____
 Estimated Operations and Maintenance Budget _____

3. SCOPE OF PROJECT:

Individuals / Departments who provided input: _____

DESCRIPTION OF PROJECT: Design and construction of an outdoor storage building for the MPD Property Unit Division. The project consists of a new 600 s.f. 16' ht. air conditioned warehouse type building with heavy duty steel storage shelves. Additional work as of September: add a 750 s.f. second floor office space above the new storage building (under construction). This new work will require design modification to the existing storage building plans and permit revisions.

ADA Compliant? YES NO N/A

Approved by Audit Committee? YES NO N/A DATE APPROVED: 7/21/09
 Approved by Bond Oversight Board? YES NO N/A DATE APPROVED: 7/28/09
 Approved by Commission? YES NO N/A DATE APPROVED: _____
 Revision(s) to Original Scope? YES NO (If YES see Item 5 below)
 Time Approval 6 months 12 months Date for next Oversight Board Update: _____

4. CONCEPTUAL COST ESTIMATE BREAKDOWN

Has a conceptual cost estimate been developed based upon the initial established scope? YES NO If yes,
 DESIGN COST: _____

CONSTRUCTION COST: _____

Is conceptual estimate within project budget? YES NO

If not, have additional funds been identified? YES NO

Source(s) of additional funds: _____

Approved by Commission? YES NO N/A DATE APPROVED: _____
 Approved by Bond Oversight Board? YES NO N/A DATE APPROVED: _____

5. REVISIONS TO ORIGINAL SCOPE

Individuals / Departments who provided input: _____

Justifications for change: _____

Description of change: _____

Fiscal Impact YES NO HOW MUCH? _____

Have additional funds been identified? YES NO

Source(s) of additional funds: _____

Time impact _____

Approved by Commission? YES NO N/A DATE APPROVED: _____

Approved by Bond Oversight Board? YES NO N/A DATE APPROVED: _____

6. COMMENTS: _____

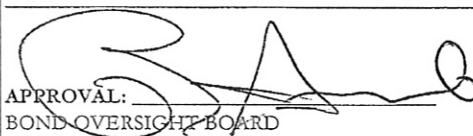
APPROVAL: 
 BOND OVERSIGHT BOARD

DATE: 7/28/09

Enclosures: Back-Up Materials YES NO

CITY OF MIAMI, FLORIDA
INTER-OFFICE MEMORANDUM

TO: Ola O. Aluko, Director
Capital Improvements Program

DATE: July 20, 2009 FILE: B-30373A

FROM: Orlando J. Diez, 
Construction Manager
Capital Improvements Program

SUBJECT: PAF Update, Police Department
Property Unit Outdoor Storage

REFERENCES: Police Department Property
Unit Outdoor Storage,
2nd Floor Addition

ENCLOSURES: PAF dated 7/15/2009

The above named project requires the following:

Description:

Attached please find the project analysis from (PAF) for Project B-30373A, Police Department Property Unit Outdoor Storage, 2nd Floor Addition, requesting additional funding for the construction of a 750 S.F. office space above the new storage building currently under construction.

Justification:

The City of Miami Police Department requested the additional office space due to Homeland Defense Training Administration proceedings. During the original construction of the outside storage facility, the additional training office was not part of the approved project.

Funding:

Funding is available to cover the work under Homeland Defense Bonds – Series 3 and Impact Fees.

cc: David J. Mendez, P.E., Assistant Director, Capital Improvements
Nelson Cuadras, Senior Construction Manger
Yvette Smith, CIP Administrator



PROJECT ANALYSIS FORM

Capital Improvements & Transportation

CIP

NON-CIP

Date Prepared: 15-Jul-2009

VERSION **REV03**

PROGRAM 312-Public Safety

AREA 1-Public Safety



PROJECT NAME: Police Department Property Unit Outdoor Storage		PROJECT NO: B-30373A
ADDRESS / LOCATION: 400 NW 2nd Avenue		DISTRICT: 1,2,3,4,5
PROJECT TEAM: Vertical	PROJECT CONTRACTED COST: \$ 471,283.12	
CATEGORY: Police	PROJECT EST. COST: \$ 870,928.00	
CLIENT DEPT: 29-POL-Police	CURRENT FUNDS: \$ 870,928.00	
CLIENT CONTACT: Martin Garcia	TEL.: (305) 603-6146	FUTURE FUNDS:
DESIGN MANAGER: Fernando Paiva (CIP)	TEL.: 305-416-1242	FUND SHORTFALL:
CONSTR. MANAGER: Orlando Diaz (CIP)	TEL.: 305-416-1047	PROCUREMENT: JOC
EST. DESIGN START: 11/20/06	EST. BID ADV.:	EST. CONSTRUCTION START: 04/14/08
EST. DESIGN END: 05/18/07	EST. AWARD DATE:	EST. CONSTRUCTION END: 09/24/09

PROJECT ESTIMATED AND ACTUAL COSTS	PRODUCTION PHASE (3-DES)		% of Const	A/E Est. Design	% of Const	PM/CM Commitments	% of Const	Contracted Design
	Consultant: 2981 Rizo, Carreno & Partners, Inc.		CODE					
	1	Outside Consultant - Prime Basic Design Fee	1.01	6.0% \$ 40,873.00				
	2	Outside Consultant - Additional Design Services	1.01	5.7% \$ 38,500.00				
	3	CIP - Production Management	1.04	5.0% \$ 33,839.00				
	4							
	PRODUCTION TOTALS			Estimated	PM/CM Commitments	Contracted		
				\$ 113,212.00		\$ 89,649.51		
	CONST. PHASE (4-CON)			A/E Estimated Construction by PM	PM/CM Commitments	Contracted Construction (Formal Bid, Informal Bid or JOC Method)		
	Contractor: 2047 GEC Associates Inc.		CODE					
1	Construction Cost (First Floor)	2.00	44% \$ 295,000.00					
2	Construction Contingency Allowance	2.00	5% \$ 33,839.00					
3	Change Orders 01 (Second Floor)	2.00	44% \$ 298,000.00					
4	Change Orders 02 (Area Outside unit storage)	2.00	7% \$ 50,000.00					
5								
CONSTRUCTION TOTALS			Estimated	PM/CM Commitments	Contracted			
			\$ 676,839.00		\$ 344,680.35			
CONST. ADMIN. (8-CEO)			A/E Estimated CEO	PM/CM Commitments	Contracted CEO			
		CODE						
1	Construction Management by CIP Construction Manager	3.04	5.0% \$ 33,839.00					
2	JOC Administration - The Gordian Group (Always 1.5%)	3.03	2.0% \$ 13,199.00					
3								
CONSTRUCTION ADMINISTRATION TOTALS			Estimated	PM/CM Commitments	Contracted			
			\$ 47,038.00		\$ 30,165.26			
ADMIN. EXPENSES (6-ADM)			A/E Estimated ADMIN	PM/CM Commitments	Contracted ADMIN			
		CODE						
1	CIP Department (Mgmt./Budget/Procurement/Comm.)	4.00	5.0% \$ 33,839.00					
2								
ADMINISTRATIVE EXPENSES TOTALS			Estimated	PM/CM Commitments	Contracted			
			\$ 33,839.00		\$ 6,788.00			
ADDITIONAL PROJECT TASKS			A/E Estimated Tasks	PM/CM Commitments	Contracted TASKS			
		CODE						
1								
ADDITIONAL PROJECT TASKS TOTALS			Estimated	PM/CM Commitments	Contracted			
B-30373A	PROJECT GRAND TOTAL		Estimated	PM/CM Commitments	Contracted			
			\$ 870,928.00		\$ 471,283.12			

PROJECT SCOPE	Design and construction of an outdoor storage building for the MPD Property Unit Division. The project consists of a new 600 s.f., 16' ht. air conditioned warehouse type building with heavy duty steel storage shelves. Additional Work as of September 2008: Add a 750 S.F. second floor office space above the new storage building (under construction). This new work will require design modification to the existing storage building plans and permit revisions.					
	Operating Cost Associated with Project:	YEAR 1	YEAR 2	YEAR 3	YEAR 4	YEAR 5

Notes	
-------	--

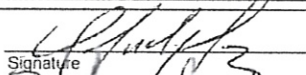
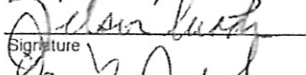
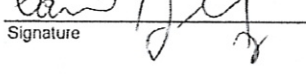
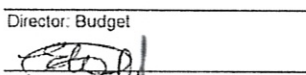
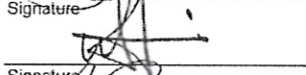
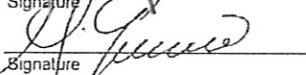
FUND SOURCES	AWARD NAME AND NUMBER		AVAILABLE	FUTURE
	1584	385200-3 2002 Homeland Defense Bonds (Series 3)	312048 Police Homeland Defense Preparedness	\$ 116,235.00
	367001 Impact Fees	312025 HeadquarterBuilding Renovations	\$ 349,178.00	
1108	367001 Impact Fees	312025 HeadquarterBuilding Renovations	\$ 36,924.00	
	367011 Impact Fees - Ord 12750	312025 HeadquarterBuilding Renovations	\$ 368,591.00	
B-30373A FUND GRAND TOTAL			ACTUAL \$ 870,928.00	PROJECTED

VALIDATION	Initiated by: Orlando Diez Project Manager: Capital Improvements		Date: 7-17-09
	Approved by: Nelson Cuadras Team Leader: Capital Improvements		Date: 7-20-09
	Accepted by: David Mendez Assistant Director: Capital Improvements		Date: 7-20-09
	Reviewed by: Yvette Smith Administrator: Budget		Date: _____
	Verified by: Edwige De Crumpe Program Controls Staff		Date: 7/15/09
	Authorized by: Ola Aluko Director: Capital Improvements		Date: 7/21/09
	Authorized by: Martin Garcia Police Department		Date: 7/15/09
ORIGINAL TO: Melanie Whitaker / Capital Improvements 8th Floor			Initials: _____

Notes	<p>Receipt of PAF by Danette Perez - CIP Public Relations Coordinator</p> <p><u>Project MUST be Presented to the Bond Oversight Board</u> Date Received / Signature or Initials</p>
-------	--

Executed PAF MUST be electronically distributed to the following individuals:
Director of the Client Department, Yvette Smith, Edwige De Crumpe, Senior Project Manager and Project Manager.

I. APPROVAL OF THE MINUTES FOR THE MEETING OF JUNE 23, 2009.

HD/NIB MOTION 09-27

A MOTION TO APPROVE THE MINUTES OF THE MEETING OF JUNE 23, 2009.

MOVED: P. Perez-Cisneros
SECONDED: M. Cruz
ABSENT: H. Arza, L. De Rosa, R. Flanders, K. Hancock-Apfel, R. Lambert, C. Matos,
J. Solares

Note for the Record: Motion passed by unanimous vote of all Board Members present.

II. NEW ITEMS:

1. Merrie Christmas Park New Swings

NAME OF PROJECT: <u>MERRIE CHRISTMAS PARK NEW SWINGS</u>
TOTAL DOLLAR AMOUNT: <u>\$60,000 (\$50,000 is Homeland Defense)</u>
SOURCE OF FUNDS: <u>Neighborhood Park Improvements</u>
ACCOUNT CODE(S): <u>3331419</u>
DESCRIPTION OF PROJECT: <u>Installation of a new swing set on a rubber surface.</u>

HD/NIB MOTION 09-28

A MOTION TO FUND MERRIE CHRISTMAS PARK NEW SWINGS.

MOVED: M. Cruz
SECONDED: P. Perez-Cisneros
ABSENT: H. Arza, L. De Rosa, R. Flanders, K. Hancock-Apfel, R. Lambert, C. Matos,
J. Solares

Note for the Record: Motion passed by unanimous vote of all Board Members present.

2. Police Department Property Unit Outdoor Storage

NAME OF PROJECT: <u>POLICE DEPARTMENT PROPERTY UNIT OUTDOOR STORAGE</u>
TOTAL DOLLAR AMOUNT: <u>\$870,928 (\$116,235.00 is Homeland Defense)</u>
SOURCE OF FUNDS: <u>Police Homeland Defense Preparedness</u>
ACCOUNT CODE(S): <u>312048</u>
DESCRIPTION OF PROJECT: <u>Design and construction of an outdoor storage building for the MPD Property Unit Division. The project consists of a new 600 s.f. 16' ht. air conditioned warehouse type building with heavy duty steel storage shelves. Additional work as of September: add a 750 s.f. second floor office space above the new storage building (under construction). This new work will require design modification to the existing storage building plans and permit revisions.</u>

HD/NIB MOTION 09-29

A MOTION TO FUND POLICE DEPARTMENT PROPERTY UNIT OUTDOOR STORAGE.

MOVED: M. Cruz
SECONDED: L. Cabrera
ABSENT: H. Arza, L. De Rosa, R. Flanders, K. Hancock-Apfel, R. Lambert, C. Matos,
J. Solares

Note for the Record: Motion passed by unanimous vote of all Board Members present.



DEPARTMENT OF CAPITAL IMPROVEMENTS
PROJECT OVERVIEW FORM

COMPLETED

1. DATE: 9/23/08 DISTRICT: 1 & 4
NAME OF PROJECT: TAMIAMI STORM SEWER IMPROVEMENTS - CONSTRUCTION SERVICES
INITIATING DEPARTMENT/DIVISION: Capital Improvements Program
INITIATING CONTACT PERSON/CONTACT NUMBER: Orlando Misas (305) 416-1038
C.I.P. DEPARTMENT CONTACT: Orlando Misas
RESOLUTION NUMBER: _____ CIP/PROJECT NUMBER: B-50706

2. BUDGETARY INFORMATION: Are funds budgeted? YES NO If yes,
TOTAL DOLLAR AMOUNT: \$2,083,918 (\$518,100 Previously Approved; \$526,389 Future Funds)

SOURCE OF FUNDS: Tamiami Storm Sewers Phase IV, HD Series 1, 2, and 3
ACCOUNT CODE(S): CIP # 352269

If grant funded, is there a City match requirement? YES NO
AMOUNT: _____ EXPIRATION DATE: _____
Are matching funds budgeted? YES NO Account Code(s): _____
Estimated Operations and Maintenance Budget _____

3. SCOPE OF PROJECT:

Individuals / Departments who provided input: _____

DESCRIPTION OF PROJECT: The proposed work consists of drainage improvements consisting of French drains, new storm sewer outfalls, catch basins, cross drains and surface restoration. Road improvements such as roadway milling and resurfacing, damaged sidewalk replacement, curb and/or gutter replacement, re-sod of swales, and ADA compliant ramp construction as needed within project limits. Additional information listed under the Notes Section on the attached Project Analysis Form.

ADA Compliant? YES NO N/A

Approved by Audit Committee? YES NO N/A DATE APPROVED: 9/16/08
Approved by Bond Oversight Board? YES NO N/A DATE APPROVED: 9/23/08
Approved by Commission? YES NO N/A DATE APPROVED: _____
Revisions to Original Scope? YES NO (If YES see Item 5 below)
Time Approval 6 months 12 months Date for next Oversight Board Update: _____

4. CONCEPTUAL COST ESTIMATE BREAKDOWN

Has a conceptual cost estimate been developed based upon the initial established scope? YES NO If yes,
DESIGN COST: _____
CONSTRUCTION COST: _____
Is conceptual estimate within project budget? YES NO
If not, have additional funds been identified? YES NO
Source(s) of additional funds: _____

Approved by Commission? YES NO N/A DATE APPROVED: _____
Approved by Bond Oversight Board? YES NO N/A DATE APPROVED: _____

5. REVISIONS TO ORIGINAL SCOPE

Individuals / Departments who provided input: _____

Justifications for change: _____

Description of change: _____

Fiscal Impact YES NO HOW MUCH? _____
Have additional funds been identified? YES NO
Source(s) of additional funds: _____

Time impact _____
Approved by Commission? YES NO N/A DATE APPROVED: _____
Approved by Bond Oversight Board? YES NO N/A DATE APPROVED: _____

6. COMMENTS: Construction will start in 60 days, 1 year project, not a phased project. City will need to sell 3rd series or borrow from general fund. City thinks it will sell Bonds in 2009 during 1st quarter. Design cost is 17.9% should be 8-12%; staff will provide actual design cost.

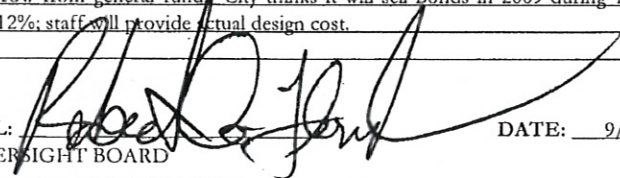
APPROVAL:  DATE: 9/23/08
BOND OVERSIGHT BOARD

Enclosures: Back-Up Materials YES NO

CITY OF MIAMI, FLORIDA
INTER-OFFICE MEMORANDUM

TO: Ola O. Aluko, Director
Capital Improvements Program

DATE: September 8, 2008 FILE: B-50706

SUBJECT: Funding for project
Tamiami Storm Sewer Improvements
Project, B-50706

FROM: Orlando Misas, Project Manager
Capital Improvements Program *OM*

REFERENCES:

ENCLOSURES: Project Analysis Form (PAF)

The above subject project requires the following:

Description:

The attached Project Analysis Form is to activate and approve funds for the project entitled "Tamiami Storm Sewer Improvements Project", B-50706.

Justification:

The project is a result of multiple resident requests to the Districts 1 and 4 Commissioner's office for neighborhood improvements. Scope of work consists of drainage improvements consisting of French drains, new storm sewer outfalls, catch basins, cross drains and surface restoration. Road improvements such as roadway milling & resurfacing, damaged sidewalks, curb and/or gutter replacement, resod of swales, and ADA compliant ramps construction as needed within project limits.

It is also necessary to construct of additional drainage in the area of NW 60th Court between NW 3rd Street and NW 5th Street and tree planting throughout the impacted subject project.

Funding:

The total cost to cover design and construction phases have been estimated in the amount of \$2,083,918.00 and are funded by the 2002 Homeland Defense Bonds Series 1, 2, and 3, CIP account No.385200-1, 385200-2, and 385200-3.

OM/om

cc: David J. Mendez, P.E., Assistant Director, Capital Improvements Program
Gary Fabrikant, Assistant Director, Capital Improvements Program
Jose L. Lago, P.E., CIP Acting Sr. Project Manager, Capital Improvements Program
Orlando Misas, Project Manager, Capital Improvements Program



PROJECT ANALYSIS FORM

Capital Improvements & Transportation

CIP NON-CIP

Date Prepared:	5-Sep-2008
VERSION	ORIGINAL

PROGRAM 352-Storm Sewers AREA 3-Infrastructure & Environment

PROJECT NAME: Tamlami Storm Sewer Improvements Project		PROJECT NO: B-50706
ADDRESS / LOCATION: Area bounded by 57 Ave, 61 Ave, SW 8 St, & NW 7 St.		DISTRICT: 1,4
PROJECT TEAM: Horizontal		PROJECT CONTRACTED COST: \$ 478,080.05
CATEGORY: Storm Sewers		PROJECT EST. COST: \$ 2,083,918.00
CLIENT DEPT: 122-T&T-Transportation & Transit		CURRENT FUNDS: \$ 1,557,529.00
CLIENT CONTACT: Ola Aluko TEL.: (305) 416-1471		FUTURE FUNDS: \$ 526,369.00
DESIGN MANAGER: Orlando Miasas (CIP) TEL.: 305-416-1038		FUND SHORTFALL:
CONSTR. MANAGER: Genady Baylin (CIP) TEL.: 305-416-1233		PROCUREMENT: Conventional
EST. DESIGN START: 11/17/04	EST. BID ADV.: 01/15/08	EST. CONSTRUCTION START: 09/20/08
EST. DESIGN END: 11/15/07	EST. AWARD DATE:	EST. CONSTRUCTION END: 04/20/09

PROJECT ESTIMATED AND ACTUAL COSTS	PRODUCTION PHASE (3-DES)		% of Const	Estimated Design	% of Const.	Contracted Design	
	Prime Consultant: 8635 A.D.A. Engineering Inc.	CODE					
	1 Outside Consultant - Prime Basic Design Fee	1.01	17.9%	\$ 246,337.00			
	2 Outside Consultant - Prime Basic Design Fee	1.01	13.1%	\$ 180,000.00			
	3 Advertising	1.04	0.2%	\$ 2,244.00			
	4						
	PRODUCTION TOTALS			Estimated	Contracted		
				\$ 428,581.00	\$ 428,580.05		
	CONSTRUCTION PHASE (4-CON)		CODE	Estimated Construction by PM		Contracted Construction (Formal Bid, Informal Bid or JOC Method)	
	Prime Contractor:						
1 Construction Cost (Prime Contractor)	2	70%	\$ 969,448.00				
2 Construction Contingency Allowance	2	8%	\$ 110,000.00				
3 Other Construction Related Services	2	22%	\$ 300,000.00				
4							
CONSTRUCTION TOTALS			Estimated	Contracted			
			\$ 1,379,448.00				
CONSTRUCTION ADMINISTRATION (8-CEO)		CODE	Estimated CEO		Contracted CEO		
1 Construction Engineering Observation (CEO) Consultant		3.01	10.0%	\$ 137,945.00			
2 Construction Management by CIP Construction Manager		3.04	5.0%	\$ 68,972.00			
3							
CONSTRUCTION ADMINISTRATION TOTALS			Estimated	Contracted			
			\$ 206,917.00				
ADMINISTRATIVE EXPENSES (6-ADM)		CODE	Estimated ADMIN		Contracted ADMIN		
1 CIP Department (Mgmt./Budget/Procurement/Comm.)		4	5.0%	\$ 68,972.00			
2							
ADMINISTRATIVE EXPENSES TOTALS			Estimated	Contracted			
			\$ 68,972.00	\$ 49,500.00			
ADDITIONAL PROJECT TASKS		CODE	Estimated TASKS		Contracted TASKS		
1							
ADDITIONAL PROJECT TASKS TOTALS			Estimated	Contracted			
B-50706 PROJECT GRAND TOTAL			Estimated	Contracted			
			\$ 2,083,918.00	\$ 478,080.05			

PROJECT SCOPE	Drainage Improvements consisting of French drains, new storm sewer outfalls, catch basins, cross drains and surface restoration. Road improvements such as roadway milling & resurfacing, damaged sidewalk replacement, curb and/or gutter replacement, resod of swales, and ADA compliant ramp construction as needed within project limits. <input type="checkbox"/>					
	Operating Cost Associated with Project:	YEAR 1	YEAR 2	YEAR 3	YEAR 4	YEAR 5

Notes
 The City of Miami CIP Office needs to increase quantity fund for the construction of additional drainage in the area of NW 60th Court between NW 3rd Street and 5th Street, and tree planting throughout the impacted subject project. a) Additional drainage construction based on per item bid \$69,178 plus b) Tree planting based on constructor prices \$60,775 for a Total of \$130,000 for a maximum of \$300,000.

FUND SOURCES	AWARD NAME AND NUMBER		AVAILABLE	FUTURE
		385200-1 2002 Homeland Defense Bonds (Serik 352269 Tamiami Storm Sewers - Ph		\$ 564,000.00
	385200-2 2002 Homeland Defense Bonds (Serik 352269 Tamiami Storm Sewers Pha		\$ 993,529.00	
	385200-3 2002 Homeland Defense Bonds (Serik 352269 Tamiami Storm Sewer Phas			\$ 526,389.00
	B-50706 FUND GRAND TOTAL		ACTUAL \$ 1,557,529.00	PROJECTED \$ 526,389.00

VALIDATION	Initiated by: Orlando Misas Project Manager		Date: 9/5/08
	Approved by: N/A Senior Project Manager	Signature	Date:
	Reviewed by: Jose Lago Project Manager		Date: 9/5/08
	Reviewed by: Yvette Maragh CIP Budget Administrator		Date: 9/5/08
	Verified by: EDWIGE DE CRUMPE Program Controls Staff	Initials: Signature:	
	Accepted by: David Mendez Assistant Director: Capital Improvements		Date: 9/19/08
	Approved by: Ola Aluko Director: Capital Improvements		Date: 9/9/08

ORIGINAL TO: Melanie Whitaker / 8th Floor

Initials:

Notes
 Receipt of PAF by Danette Perez - CIP Public Relations Coordinator
Project MUST be Presented to the Bond Oversight Board
 Date Received: 9/9/08 / Signature or Initials:

Executed PAF MUST be electronically distributed to the following individuals:
 Director of the Client Department, Yvette Maragh, Edwige De Crumpe, Senior Project Manager and Project Manager.

• Tamiami Storm Sewer Improvements – Construction Services

NAME OF PROJECT: TAMIAMI STORM SEWER IMPROVEMENTS – CONSTRUCTION SERVICES
TOTAL DOLLAR AMOUNT: \$2,083,918 (\$518,100 Previously Approved; \$526,389 Future Funds)
SOURCE OF FUNDS: Tamiami Storm Sewers Phase IV, HD Series 1, 2, and 3
DESCRIPTION OF PROJECT: The proposed work consists of drainage improvements consisting of French drains, new storm sewer outfalls, catch basins, cross drains and surface restoration. Road improvements such as roadway milling and resurfacing, damaged sidewalk replacement, curb and/or gutter replacement, re-sod of swales, and ADA compliant ramp construction as needed within project limits. Additional information listed under the Notes Section on the attached Project Analysis Form.

HD/NIB MOTION 08-28

A MOTION TO FUND THE TAMIAMI STORM SEWER IMPROVEMENTS - CONSTRUCTION SERVICES.

MOVED: K. Apfel
SECONDED: M. Cruz
ABSENT: H. Arza, L. Cabrera, J. Reyes

Note for the Record: Motion passed by unanimous vote of all Board Members present, with the exception of Gary Reshefsky.

III. UPDATES:

1. Commodore Plaza Street Furniture

Gary Reshefsky stated that the project has been completed.

Elyrosa Estevez, Public Works, reported that two metal benches were installed at 3138 Commodore Plaza on brick pavers, and the project is 100 percent completed.

2. Historic Preservation Initiatives – City Hall

Gary Reshefsky stated that study of the columns is being finalized. The columns are currently being encased in concrete, and the project should be completed within six months.

Robert Fenton, CIP Department, stated that the remediation work has not started yet. The engineering work is complete. The contracts have been awarded to the contractor and the shop drawings are currently being reviewed to start the repairs.

3. Bicentennial Park Shoreline Stabilization, Phase III - Construction Services

Gary Reshefsky stated that the project has been a great project for the City and it has been completed.

David Méndez, Assistant Director, CIP, reported that the project has been completed on time and under budget.

6. Fairlawn Storm Sewer Improvements Phase III – Design Services

Ola Aluko, CIP Director, reported that the project is 95 percent complete in terms of design. Once construction is completed, the drainage will be addressed and landscaping will be added. More trees are being added to the project than in its original state. Construction is expected to begin shortly after the June 2009 permit date.

7. Tamiami Storm Sewer Improvements – Construction Services

Genady Beylin, CIP Department, reported that the improvements include drainage improvements. The project is located between Northwest 58th Court and 62nd Avenue, from Southwest 7th Street and Northwest 7th Street. The drainage installation is 60 percent complete. The anticipated completion date is August 2009.

V. CHAIRPERSON'S OPEN AGENDA:

- o JOC, Conventional Bid, Design-Build Report

Eileen Broton stated that the Board requested a report detailing the projects utilizing the JOC method of acquisition versus conventional bid versus design-build. She noted for the record that the report was provided to the Board.

Ola Aluko, CIP Director, stated that he would like to defer the explanation of the report to the next Board meeting because the original requestor of the report requested to add two additional columns of information to the report.

VI. ADDITIONAL ITEMS:

5. Fairlawn Storm Sewer Improvements Phase III – Design Services

Eileen Broton reported that the project scope includes road and street improvements, including trenches and piping for runoff within the area bounded by Southwest 8th Street and West Flagler Street and Southwest 47th Avenue and Southwest 57th Avenue. The design is 100 percent complete and the project will go out for bid and construction estimates to begin in November.

Gary Fabrikant reported that the project is currently out to bid. The bids are due this Thursday. Award is expected some time by the end of November or beginning of December. Construction is anticipated to begin in January 2010.

6. Tamiami Storm Sewer Improvements – Construction Services

Eileen Broton reported that the construction is complete and under budget. There were added site improvements made for drainage of areas near the initial project that could be dovetailed. Final completion of this work is estimated for late October.

Genady Beylin, Project Manager, CIP Department, reported that there were several additional change orders added to the work requested by the City. The project has been expanded a little so completion of the project is estimated for mid-November. The project is currently on budget and savings are expected.

IV. CHAIRPERSON'S OPEN AGENDA:

Chairman Flanders spoke of the board's accomplishments and expressed his gratitude to fellow board members for their dedicated service and contributions as members of the Homeland Defense/Neighborhood Improvement Bond Oversight Board.

Chairman Flanders stated his resignation from the Homeland Defense/Neighborhood Improvement Bond Oversight Board.

V. ADDITIONAL ITEMS:

➤ PAF Forms

There will be an additional fourth column on the project analysis form for all new projects as requested by the Board. All new projects will have the fourth column to show estimated cost and actual cost so that the history of the cost is on one page, providing a dashboard view .

Follow-Up Item #1

Perez, Danette

From: Valdes, Madeline
Sent: Wednesday, March 10, 2010 10:33 AM
To: Perez, Danette
Cc: Saenz, Pilar
Subject: RE: Follow-up Items Requested at the 2/23/10 BOB Meeting

Hi Danette and Pili:

We purchased 14.42 acres of land for Little Haiti Park. It is not all green space as you know we had the cultural component and the recreational component.

The property located at 1814 Brickell Avenue is approx. 35,500 sq. ft. in size. The funds for purchase came from the following sources as provided to me by Pilar:

New Project #: B-30685
Title: Brickell Avenue Park Land Acquisition
Capital Fund: 35000

Award 1496, Sunshine State Loan #2, \$460,000
From: B-30153J in fund 34000, \$460,000
To: B-30685 in fund 35000, \$460,000
Note: This transfer crosses funds.

P = 40-B30685
A = 1496
T = 07
E = Land
O = 221100
\$460,000

Award 1584, Homeland Defense Bonds (District 2 – Quality of Life), \$500,000
From: B-39910 in fund 31000, \$500,000
To: B30685 in fund 35000, \$500,000
Note: This transfer crosses funds.

P = 40-B30685
A = 1584
T = 07
E = Land
O = 221100
\$500,000

Award 1422, Impact Fees, \$1,300,000
From: B-30635, \$916.76
From: B-30636, \$9,287
From: B-35853A, \$500,000
From: B-30638, \$100,000
From: B-35898, \$120,402.09
From: B-35906, \$92,886.90
From: B-75883, \$299,876.95
From: B-30639, \$99,607.49
From: B-30640, \$26,103.75
From: B-30642, \$50,000
From: B-35894A, \$919.06
All above in fund 35000

To: B-30685 in fund 35000, \$1,300,000
Note: These transfers are within the same fund 35000.

P = 40-B30685
A = 1422
T = 07
E = Land
O = 221100
\$1,300,000

Safe Neighborhoods, \$327,000 (to be received)

I don't know of any plan for purchasing new park land as we are currently facing a financial crises and may not have funds to maintain a park. You may want to discuss this further with Ernest, as he may be aware of such a plan.

Hope this helps,

Madeline Valdes, Director
City of Miami
Department of Public Facilities
444 SW 2nd Avenue, Suite 325
Miami, FL 33130
(305)416-1461 bus.
(305)416-2156 fax
mvaldes@miamigov.com

From: Perez, Danette
Sent: Tuesday, March 09, 2010 10:02 AM
To: Valdes, Madeline
Cc: Saenz, Pilar
Subject: Follow-up Items Requested at the 2/23/10 BOB Meeting

Hi Madeline:

We need the information (see my email below) on the number of acres of park land that have been purchased to date with Homeland Defense Neighborhood Improvements Bond dollars for the 3/17/10 BOB Audit Subcommittee Meeting.

Your assistance in this matter is greatly appreciated.

Thanks,
Danette Perez, Public Relations Coordinator
"Building Better Neighborhoods"
City of Miami - Capital Improvements Program
444 SW 2 Avenue - 8th Floor
Miami, Florida 33130
Ph: (305) 416-1286
Fax: (305) 400-5042
Email: daperez@miamigov.com
Website: www.miamigov.com/capitalprojects



From: Perez, Danette
Sent: Thursday, March 04, 2010 12:35 PM

MIAMI PARKS AND PUBLIC SPACES MASTER PLAN

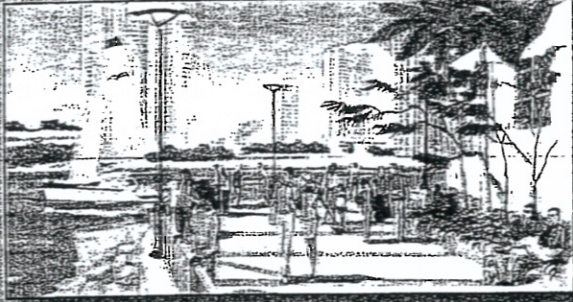

MAY 2007 | THE CITY OF MIAMI
PARKS & RECREATION DEPARTMENT AND PLANNING DEPARTMENT

PREPARED BY GOODY CLANCY
WITH DODSON ASSOCIATES | GREENPLAY LLC | LEISURE VISION | ROSENBERG GARDNER DESIGN

Acquisition and Expansion

All observers acknowledge that Miami's park system is relatively small for its size and population density. While land was relatively inexpensive, the City had very few resources. Now that Miami has begun attracting more investment, the City faces rising land prices, in addition to the always-complex issues of creating new open spaces in a built-up community where new parks could mean dislocation of businesses or residents. As the City makes acquisitions to meet the interim goal of a park within a half-mile of every residence, it should then continue its efforts, advancing towards the goal of a park within one-quarter mile of every Miami home. There are a variety of ways for the City to acquire new park land, including conversion of public land, outright purchase, tax title, infrastructure projects, eminent domain and developer contributions.

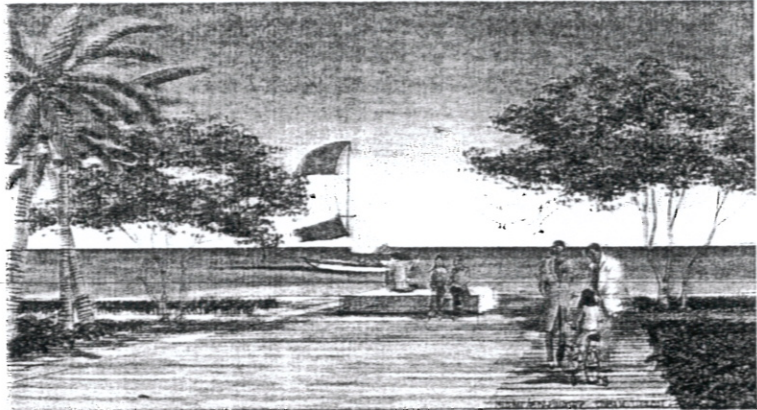

All streets that terminate at Biscayne Bay should include public spaces.



Conversion of Public Land to Parks

There are several areas in Miami where land in public ownership could be converted into small park and open space amenities. Every street that ends at Biscayne Bay should have a public space overlooking the bay. On small streets a bench and attractive railing can provide a place to sit and look at the water. On larger streets a bigger area could be designated as a public space, with the potential for a belvedere or platform overhanging the water, or a pocket park. Consolidation of existing public right of way into small parks also may be possible in certain residential areas, such as in Flagami on NW and SW 2nd streets and NW and SW 66th Avenue, where there are small traffic circles. There is more right of way than is being used or is needed, leaving the possibility of creating small parks, possibly with pedestrian cut-throughs, and rerouting traffic around them.

Purchase

- Purchase of land for parks should be considered both for citywide parks and for neighborhood parks. High-priority locations or types of park land, based on community preferences, are:
- land with water views or water access;
 - new walk-to parks in underserved areas of the city;
 - expansion of existing community parks; and
 - land for expansion or creation of linear parks.

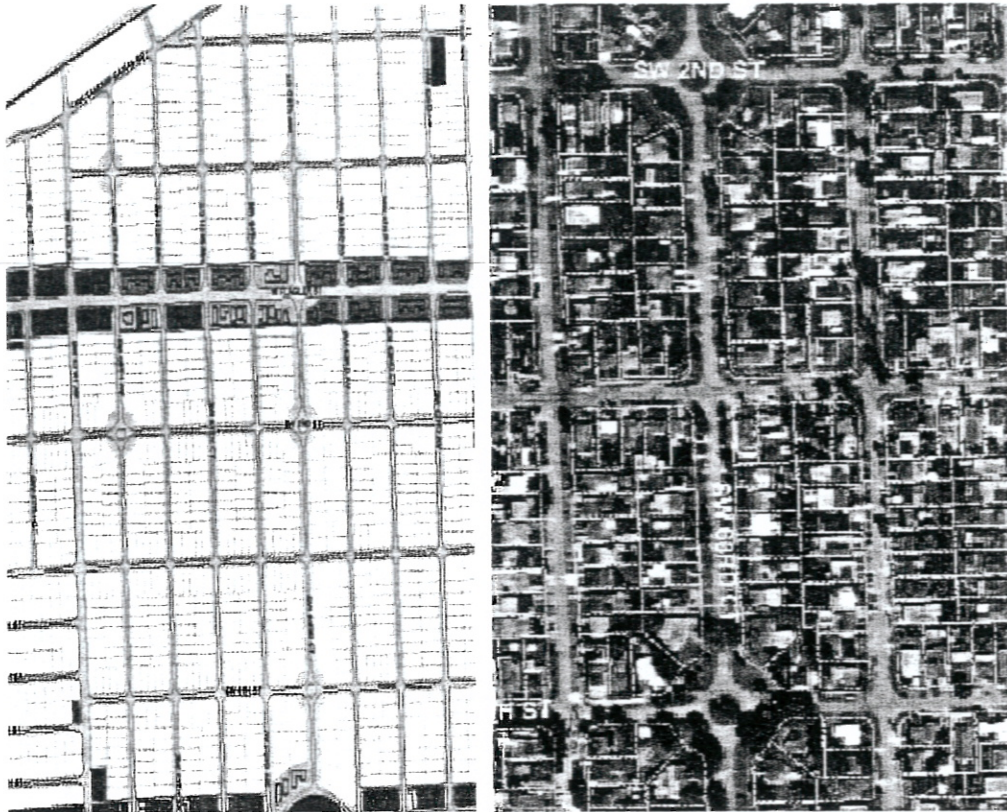

In Flagami, streets could be reconfigured to create new neighborhood mini-parks at locations with traffic circles or wide intersections.

acquiring large amounts of land for parks may be substantial. Potential sources of acquisition funds include impact fees, developer public benefit payments, bonds, designated fees or taxes, grants, infrastructure projects, and foundations.

Land occupied by a trailer park was recently acquired for Little Haiti Park and the Caribbean Cultural Center at a cost of \$6.6 million. The 2005 Tischler-Bise impact fee study adjusted that price upward to \$8.0 million, or \$50 per square foot, to reflect market changes. Although the real estate boom in Miami has moderated somewhat as of this writing, the cost to the City of

Redevelopment, Land Assembly and Land Swaps

Land use transitions in some of the city's industrial or commercial areas may bring more residential uses. In those cases, the new residents will need access to parks and recreation. The City can assist in assembling land parcels for important development projects. As part of that assistance, it should require open space contributions that include both small passive parks and multi-purpose community parks. The City can also facilitate land swaps in order to make land available for park uses.

Surface Parking Lot Conversions

Many acres in Miami are covered by surface parking lots. As Miami's land has become more valuable, it becomes possible for new residential and other development projects to carry the costs of underground or structured parking. Using some of the land that is liberated from car storage for parks, plazas and other open spaces will enhance the value of lands around the public spaces while providing opportu-

⁶ See www.seattle.gov/util/About_SPU/Drainage_&_Sewer_System/Natural_Drainage_Systems/Street_Edge_Alternatives/index.asp

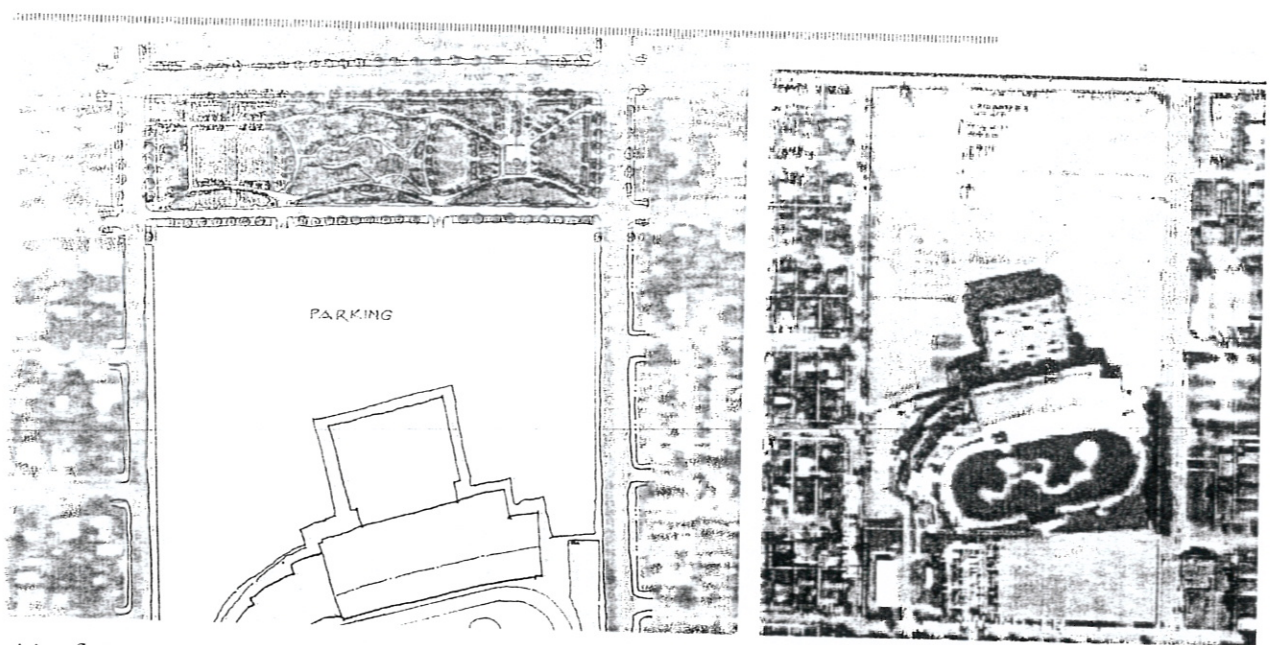

nities for residents. An example of the possibilities inherent in large parking lots is the potential redevelopment of the Flagler Dog Track on NW 7th Street.

The Flagler Dog Track is surrounded by acres of parking. Redevelopment could provide for a public park on NW 7th Street or elsewhere on the site.

Infrastructure Projects

Infrastructure improvement projects for transportation, stormwater and drainage offer the potential to expand existing parks, create new ones, and provide natural green areas. Street and highway projects should always be scrutinized for their potential to enhance the parks and open space system. Efforts to minimize runoff and treat stormwater close to the source, driven by EPA Phase II Stormwater Regulations, will incorporate green strips and mini-parks in streets, stormwater parks, biofilters, and naturalized infiltration areas. Whether large or small, these areas can help in flood control while making a place for both people and nature. Cities such as Seattle are developing model programs of natural drainage with attractive green plantings on neighborhood streets.⁶

A greenway along the Little River could be created through a combination of public acquisition and redevelopment.

Developer Contributions

Developer contributions to create new parks and public spaces can come about in a variety of ways. Miami's new zoning is expected to include provision for bonus floor development in return for payments for parks and other public benefits. Parks and public spaces can also be created through negotiation; for example, when the City facilitates site assembly through closing alleys it should require park or other public space amenities that are comparable to the area being given up.

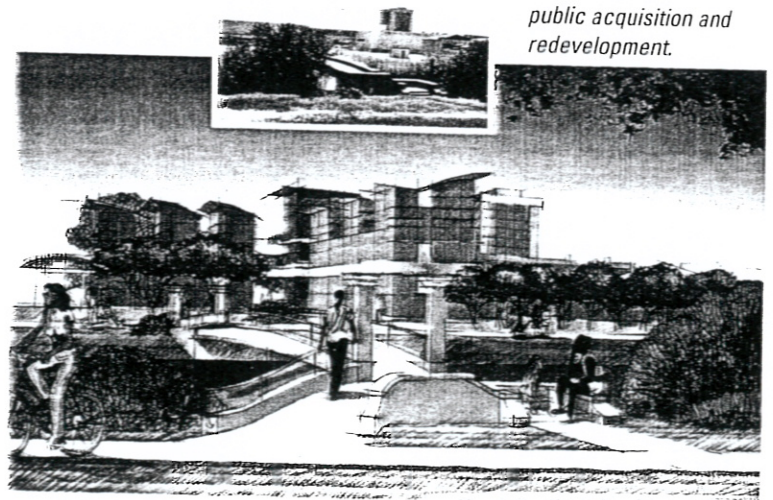

Tax Title, Eminent Domain and Similar Acquisition

Although eminent domain is normally an acquisition method of last resort, it may be appropriate in cases where abandoned property, property with repeated and extreme code violations, or undesirable land uses occupy land that would be suitable for parks. When the City has the opportunity to acquire land in tax title or similar methods, the property should be evaluated for its potential use as park land.

Donations

Land has historically been donated for parks in Miami and other communities. For example, the Ichimura Japanese Garden was a donation to the city. The City should encourage donations, especially to meet the park priorities outlined in this plan. Because every future park comes with ongoing maintenance costs, potential donations should be evaluated for both benefits and costs.

Transfer of Development Rights

As an incentive for park and public space creation, the City should make it possible for private organizations (nonprofit as well as for-profit) that provide park resources open to the public to sell their development rights to developers in zoning districts where bonus floors are available. A valuation system would need to be created to make this work and sale of the development rights would require a deed restriction for permanent protection for public open space access.

E. MAKING ACCESS REAL THROUGH STRONG CONNECTIONS

RECOMMENDATIONS

- > Complete the Riverwalk and the Baywalk and expand the public access setback requirement along the entire river.
- > Continue to implement sidewalk and shade tree planting programs along major arterials that connect to parks and other community destinations.
- > Create a "ParkWalks Program" of marked and signed safe pedestrian routes through neighborhoods in order to link residents to their local parks and promote healthy lifestyles through walking.
- > Encourage residents to create linear parks on residential street swales by providing guidance and collaboration with the Departments of Planning, Parks, Transportation and Public Works.
- > Make blueway connections real by expanding recreational boating programs, providing public shuttles to the islands, and exploring ways to make creeks and canals navigable.

- > Enhance and redesign the M-Path for greater safety, security, and connections to surrounding neighborhoods, the Riverwalk/Greenway, and to cross the Miami River to connect with the Commodore Trail.
- > Build the Overtown Greenway to link downtown to the river through Overtown.
- > Build the Flagler Trail along the FEC Corridor from downtown to the Upper Eastside.
- > Explore the potential for a Tamiami Greenway to follow the Tamiami Canal from the Miami River to the Blue Lagoon.
- > Create the Venetian Connector to Miami Beach for bicyclists and pedestrians.
- > Pursue links to regional trails in partnership with Miami-Dade County and neighboring communities.

Without connections, parks and public spaces cannot function as a system. The connective tissue of a park system is made up of the streets, paths, trails and waterways that let people reach their parks and other open spaces. The master plan survey and workshops made it clear that Miami residents would like more opportunities for safe and appealing walking and biking throughout the city. They want more access to the water—and to the park lands that can only be reached by water. They want more parks they can walk to, but they need comfortable connections, protected from traffic and with safe intersection crossings, shady during the heat of the day, and well lit in the evening and at night.

Complete the Baywalk and the Riverwalk

The vision for a connected Miami Riverwalk and Baywalk has been kept alive for decades and, with segments of both in existence and under construction, the vision is approaching reality. Many resources have been expended and committed to both, and the value of these continuous public connections along the waterfront in downtown is well understood.

The Baywalk

The vision for the Baywalk is a continuous waterside pathway from Margaret Pace Park to the Riverwalk. Less discussed is the potential for a Baywalk continuation along Brickell to Coconut Grove. Connecting from Margaret Pace south to the future Museum Park is physically viable, but will require access across several private developments, including the Miami Herald site, and negotiation across or beneath the Venetian and MacArthur causeways. Likewise, extension of the Baywalk south along the Brickell waterfront to Coconut Grove



Connecting the Baywalk and the Riverwalk is a high priority.

NE 2nd Ave Improvements Project Construction Funding & Cost Estimates

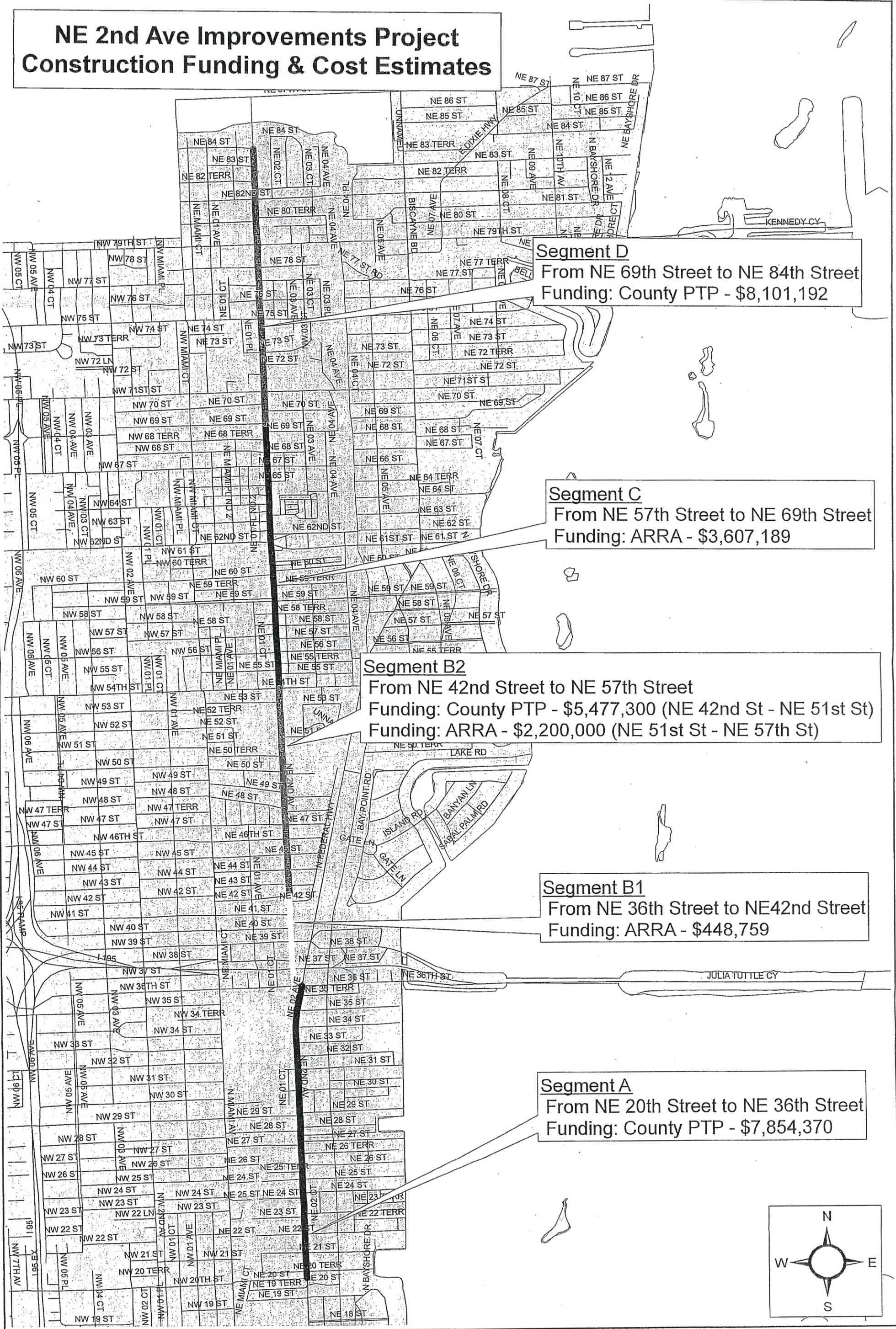

Segment D
From NE 69th Street to NE 84th Street
Funding: County PTP - \$8,101,192

Segment C
From NE 57th Street to NE 69th Street
Funding: ARRA - \$3,607,189

Segment B2
From NE 42nd Street to NE 57th Street
Funding: County PTP - \$5,477,300 (NE 42nd St - NE 51st St)
Funding: ARRA - \$2,200,000 (NE 51st St - NE 57th St)

Segment B1
From NE 36th Street to NE 42nd Street
Funding: ARRA - \$448,759

Segment A
From NE 20th Street to NE 36th Street
Funding: County PTP - \$7,854,370

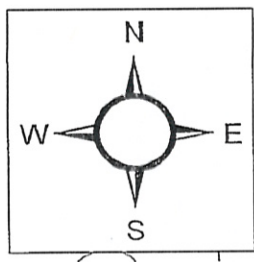

NE 2ND AVENUE STREET IMPROVEMENT

- SEGMENT A** NE 20TH TO NE 36TH STREET *(PENDING COUNTY APPROVAL)*
- SEGMENT B1** NE 36TH TO NE 42ND STREET
- SEGMENT B2** NE 42ND TO NE 54TH STREET
- SEGMENT C** NE 54TH TO NE 69TH STREET
- SEGMENT D** NE 69TH TO NE 84TH STREET

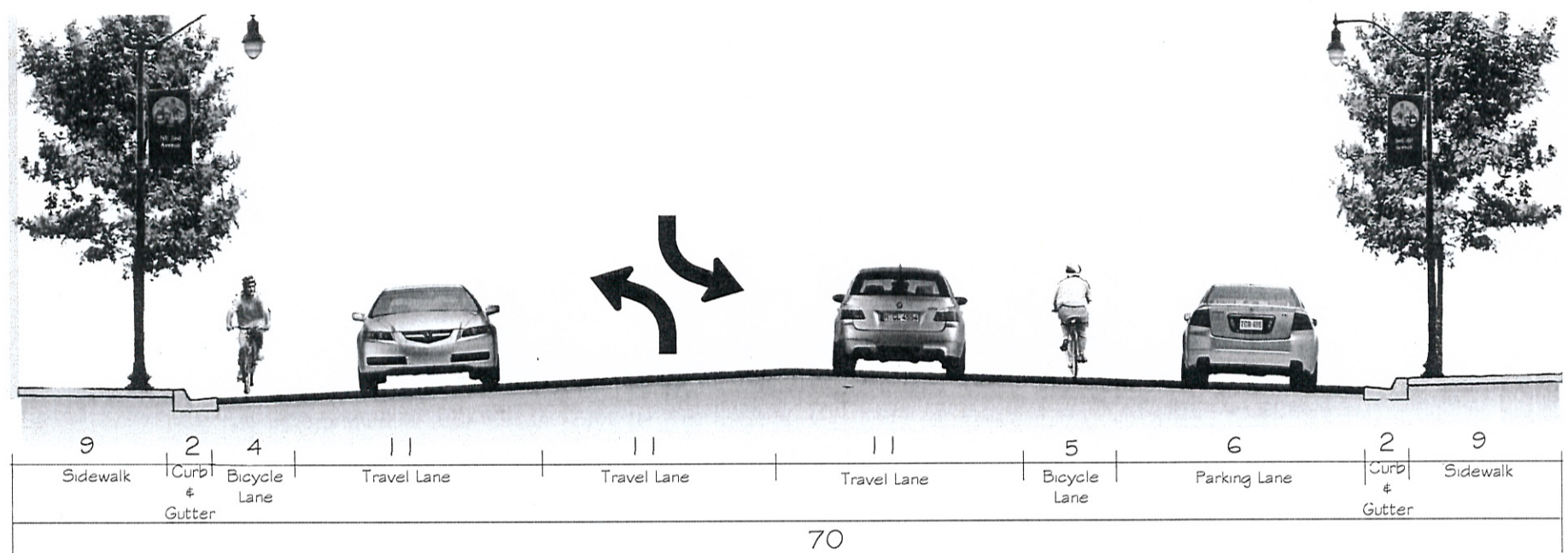
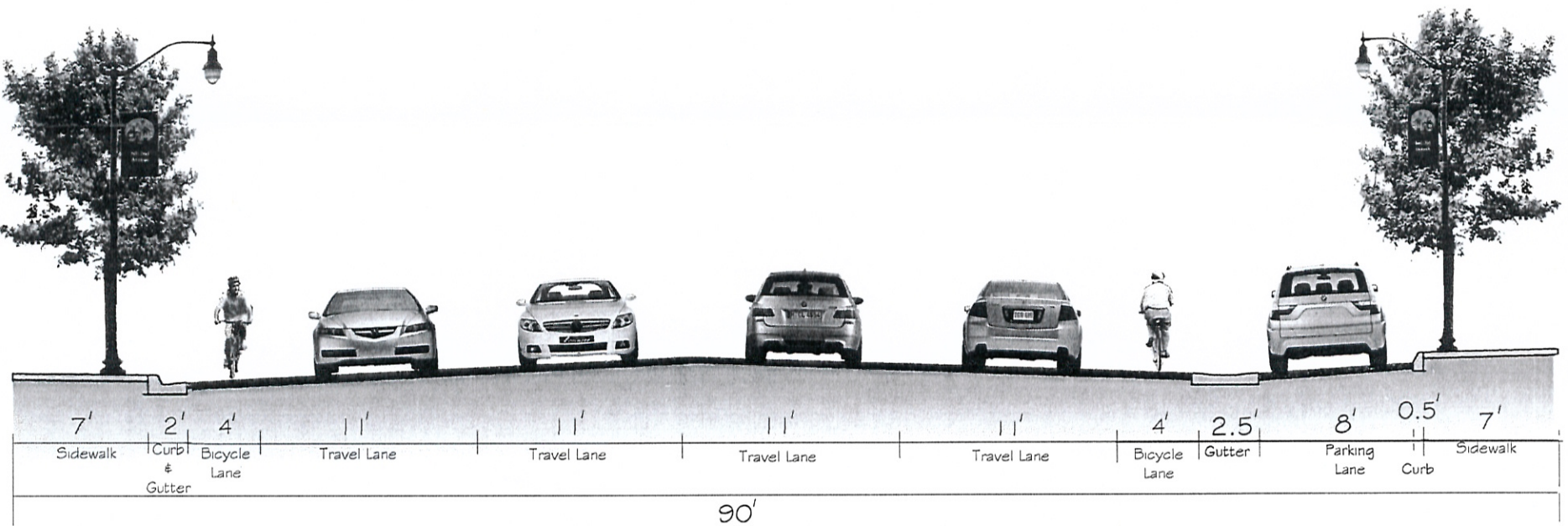
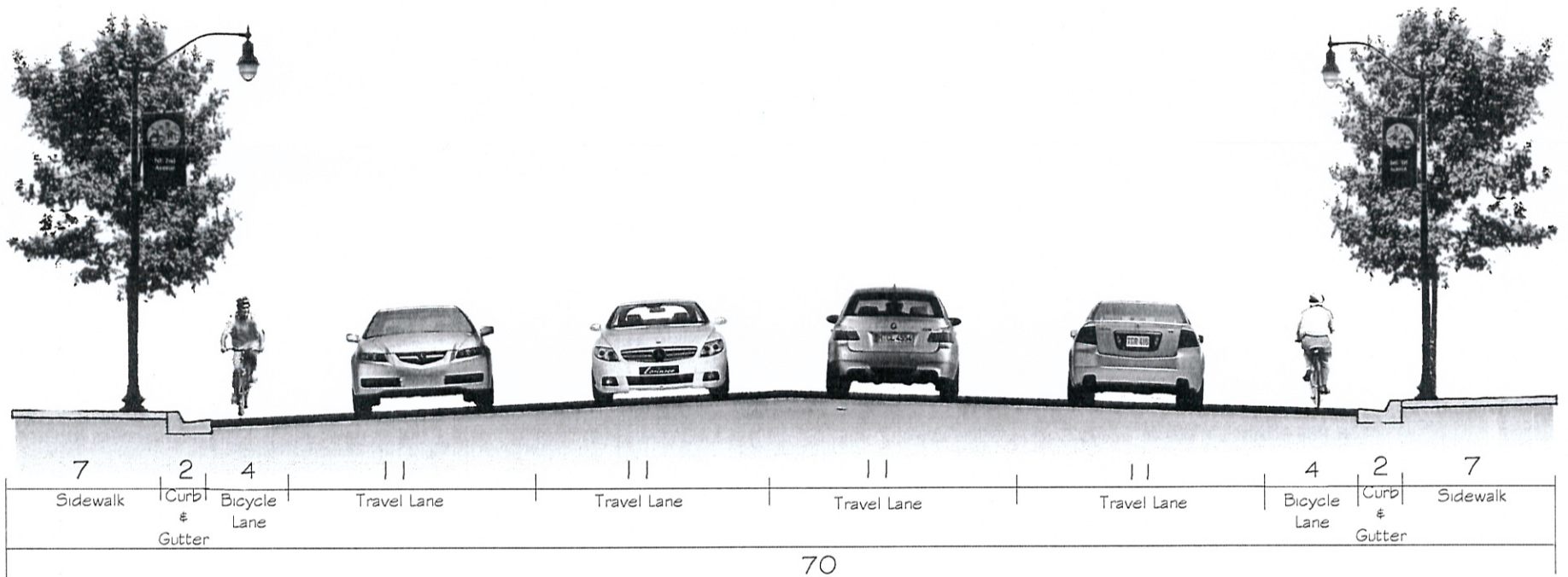

TYPICAL SECTIONS

NE 2nd Avenue

Project	Scope	Construction Estimates * / Bid Costs	CEI Funding Estimates*	Funding Source	% Completed or Scheduled Construction	Status / Comments
Segment A (20th-36th St.)	The Work includes furnishing all materials, labor, and equipment necessary for the road reconstruction, which shall also include but is not limited to storm water system, sidewalk, curb and gutter, signage, pavement markings, decorative lighting, signalization, and landscape improvements of the NE 2nd Ave. roadway between NE 57th and NE 69th streets.	\$7,354,370 *	\$370,000	County PTP	Construction = Sept. 2010 - Sept. 2011	60% complete for design. Design scheduled to be complete in June.
Segment B1 (36th-42nd St.)	The Work includes furnishing all materials, labor, and equipment necessary for the milling and resurfacing of the road, which shall also include but is not limited to sidewalk, curb and gutter, signage, pavement markings, decorative lighting, signalization, and landscape improvements of the NE 2nd Ave. roadway between NE 36th and NE 42nd streets.	\$448,759	\$75,000	ARRA	Construction = April - August 2010	Construction Start pending CEI Contract Execution. Negotiations with CEI expected to be complete this week with contract executed April 5th, 2010.
Segment B2 (42th-57th St.)	The Work includes furnishing all materials, labor, and equipment necessary for the road reconstruction, which shall also include but is not limited to storm water system, sidewalk, curb and gutter, signage, pavement markings, decorative lighting, signalization, and landscape improvements of the NE 2nd Ave. roadway between NE 42th and NE 57th streets.	\$7,677,299.52 *	\$380,000	ARRA (estimated \$2.2M) & County (\$5,477,299.52)	Construction = Sept. 2010 - May 2011	ARRA Portion of project - (51st - 57th) 90% Design; funded from remaining allocations for B1 and C. 100% Plans to be submitted to FDOT in April. FDOT to review and provide LAP. Bidding can commence upon LAP receipt estimated by July.
Segment C (57th-69th St.)	The Work includes furnishing all materials, labor, and equipment necessary for the road reconstruction, which shall also include but is not limited to storm water system, sidewalk, curb and gutter, signage, pavement markings, decorative lighting, signalization, and landscape improvements of the NE 2nd Ave. roadway between NE 57th and NE 69th streets.	\$3,607,189	\$350,000	ARRA	Construction = April 2010 - June 2011	Construction Start pending CEI Contract Execution. Negotiations with CEI expected to be complete this week with contract executed April 5th, 2010.
Segment D (69th-84th St.)	The Work includes furnishing all materials, labor, and equipment necessary for the road reconstruction, which shall also include but is not limited to storm water system, sidewalk, curb and gutter, signage, pavement markings, decorative lighting, signalization, and landscape improvements of the NE 2nd Ave. roadway between NE 57th and NE 69th streets.	\$8,101,192 *	\$400,000	County PTP	Construction = July 2010 - July 2011	90% complete for design. Design scheduled to be complete in May.

Note - \$829,000 has been expended to date on design costs allocated from HD funds.

Perez, Danette

From: Lopez, Marcia
Sent: Tuesday, March 16, 2010 4:14 PM
To: Aluko, Ola O.; Perez, Danette
Cc: Jaramillo, Wendy
Subject: FW: Roberto Clemente Park New Dorothy Quintana Community Center
Attachments: R.Clemente.JPG; R. Clemente front.JPG

fyi

Marcia Lopez

Public Relations Specialist
City of Miami - Office of Capital Improvements Program
Phone: 305.416.1063 ~ Fax: 305.416.2153 ~ [Website](#)



Please consider the environment before printing this e-mail

From: Diez, Orlando
Sent: Tuesday, March 16, 2010 4:10 PM
To: Lopez, Marcia
Subject: RE: Roberto Clemente Park New Dorothy Quintana Community Center

Marcia
Roberto Clemente: Contract amount \$ 1,750,000.00. Payment to date \$ 1,562,330.07
Thank you



Orlando J. Diez

Construction Manager II
Capital Improvement Program
Miami Riverside Center
444 S.W. 2nd Avenue, 8th Floor, Miami, FL 33130
Office (305) 416-1047 -Cell (786)447-9815

This communication may contain confidential and/or otherwise proprietary material and is thus for use only by the intended recipient. If you received this in error, please contact the sender and delete the e-mail and its attachments from all computers.

From: Lopez, Marcia
Sent: Tuesday, March 16, 2010 3:49 PM
To: Diez, Orlando
Cc: Cuadras, Nelson; Perez, Danette; Jaramillo, Wendy
Subject: FW: Roberto Clemente Park New Dorothy Quintana Community Center

Reminder: tomorrow is the Audit subcommittee meeting.

We are still pending the cost paid to the contractor for Dorothy-Q and PP slide for the outdoor storage facility.

HOMELAND DEFENSE / NEIGHBORHOOD IMPROVEMENT BOND PROGRAM

DIST (s)	PROJECT NAME	PROJECT NO.	TOTAL PROJECT ALLOCATION	TOTAL HD ALLOCATION	OTHER SOURCES ALLOCATION	TOTAL HD INVOICED TO DATE	HD UNSPENT
1	Antonio Maceo Park	B-35905	\$ 106,547	\$ 50,000	\$ 56,547	\$ 8,753	\$ 41,247
1	Antonio Maceo Park New Community Building	B-60430	\$ 1,217,381	\$ 807,454	\$ 409,927	\$ 807,454	\$ -
1	Antonio Maceo Park New Community Building Additional Services	B-60430A	\$ 118,833	\$ 90,124	\$ 28,709	\$ 90,124	\$ -
1	Curtis Park Bleacher Renovations	B-30319	\$ 435,346	\$ 366,930	\$ 68,416	\$ 366,930	\$ -
1	Curtis Park Building "NET Office" Remodeling	B-60483	\$ 251,775	\$ 248,344	\$ 3,431	\$ 248,344	\$ -
1	Curtis Park New Pool Facility	B-35806	\$ 1,806,454	\$ 1,297,159	\$ 509,295	\$ 21,512	\$ 1,275,647
1	Curtis Park Playground Equipment and Site Furnishi	B-35808	\$ 173,439	\$ 169,669	\$ 3,770	\$ 169,669	\$ -
1	Curtis Park Sports Turf Improvements	B-35811	\$ 1,507,977	\$ 63,157	\$ 1,444,820	\$ 63,157	\$ -
1	Curtis Park Track Renovation	B-30068	\$ 83,678	\$ 83,678	\$ -	\$ 83,678	\$ -
1	Duarte Park Building Renovation / Expansion	B-35812A	\$ 1,609,977	\$ 1,049,977	\$ 560,000	\$ -	\$ 1,049,977
1	Duarte Park Building Renovation/Expansion	B-35812	\$ 30,923	\$ 30,923	\$ -	\$ 30,923	\$ -
1	Duarte Park Parking Lot Improvements	B-35818	\$ 43,819	\$ 43,819	\$ -	\$ 43,819	\$ -
1	Duarte Park Playground Equipment	B-35816	\$ 64,000	\$ 64,000	\$ -	\$ 64,000	\$ -
1	Duarte Park Site Furnishings	B-35815	\$ 19,998	\$ 19,998	\$ -	\$ 19,998	\$ -
1	Duarte Park Walkway Upgrades & ADA Paths	B-35817	\$ 60,156	\$ 60,156	\$ -	\$ 60,156	\$ -
1	Fairlawn Storm Sewer Pump Station Proj Ph 2A	B-50702	\$ 2,521,139	\$ 2,497,723	\$ 23,416	\$ 2,497,723	\$ -
1	Fern Isle Clean-Up Project	B-40670	\$ 607,987	\$ 607,987	\$ -	\$ 607,987	\$ -
1	Fern Isle Park	B-30316	\$ 6,333,228	\$ 6,138,041	\$ 195,187	\$ 6,021,259	\$ 116,782
1	Flo Jo Monument at Curtis Park	B-60492	\$ 16,240	\$ 16,240	\$ -	\$ 16,240	\$ -
1	Grapeland Heights Park Site Development - Ph1	B-60496	\$ 15,342,086	\$ 8,137,808	\$ 7,204,278	\$ 8,137,808	\$ -
1	Grapeland Park Com. Rec. Facility & Prkg. Lot - Ph3	B-30105	\$ 1,496,577	\$ 927,926	\$ 568,651	\$ 927,926	\$ -
1	Grapeland Park Site Furnishings	B-35827	\$ 25,000	\$ 25,000	\$ -	\$ 25,000	\$ -
1	Kinloch Park Community Recreation Building Improvements	B-35832	\$ 695,084	\$ 695,084	\$ -	\$ 695,084	\$ -
1	Kinloch Park Court Upgrades	B-35831	\$ 9,950	\$ 9,950	\$ -	\$ 9,950	\$ -
1	Kinloch Park Site Furnishings	B-75807	\$ 132,318	\$ 106,358	\$ 25,960	\$ 106,358	\$ -
1	Melrose Park Fence Installation	B-30067	\$ 31,522	\$ 22,022	\$ 9,500	\$ 22,022	\$ -
1	Neighborhood Gateways - District 1	B-30141	\$ 50,000	\$ 50,000	\$ -	\$ -	\$ 50,000
1	NW 14 Street Project	B-50686	\$ 2,907,281	\$ 790,752	\$ 2,116,529	\$ 790,752	\$ -

HOMELAND DEFENSE / NEIGHBORHOOD IMPROVEMENT BOND PROGRAM

DIST (s)	PROJECT NAME	PROJECT NO.	TOTAL PROJECT ALLOCATION	TOTAL HD ALLOCATION	OTHER SOURCES ALLOCATION	TOTAL HD INVOICED TO DATE	HD UNSPENT
1	NW 19th Terrace	B-30228	\$ 448,354	\$ 135,260	\$ 313,094	\$ 135,260	\$ -
1	Parks ADA Modifications - District 1	B-30547D	\$ 87,440	\$ 87,440	\$ -	\$ 26,296	\$ 61,144
1	Pine Heights Park Playground Equip.	B-30069	\$ 29,401	\$ 29,401	\$ -	\$ 29,401	\$ -
1	Sewell Park - Boat / Kayak Launch Area	B-30386	\$ 100,281	\$ 27,706	\$ 72,575	\$ 27,706	\$ -
1	Sewell Park Restroom Demolition	B-35835	\$ 7,800	\$ 7,800	\$ -	\$ 7,800	\$ -
1	Sewell Park Restroom/Office Facility	B-35834	\$ 46,677	\$ 46,677	\$ -	\$ 46,677	\$ -
1	Sewell Park Steel Picket Fence	B-75810	\$ 53,950	\$ 53,950	\$ -	\$ 53,950	\$ -
1	West End Park New Community Building	B-30690	\$ 1,409,071	\$ 1,409,071	\$ -	\$ -	\$ 1,409,071
2	Alice Wainwright Park Site Improvements	B-35906	\$ 283,803	\$ 75,000	\$ 208,803	\$ -	\$ 75,000
2	Armbrister Park Site Improvements	B-75816	\$ 110,001	\$ 110,001	\$ -	\$ -	\$ 110,001
2	Armbrister Recreation Building Improvement	B-75814	\$ 558,336	\$ 558,336	\$ -	\$ 558,336	\$ -
2	Art Museum-Contribution to Park Master Plan	B-30170	\$ 621,415	\$ 621,415	\$ -	\$ 621,415	\$ -
2	Belle Meade Playground	B-75821	\$ 45,000	\$ 45,000	\$ -	\$ -	\$ 45,000
2	Bicentennial / Museum Park Mooring Bollards	B-30538A	\$ 1,809,455	\$ 250,000	\$ 1,559,455	\$ -	\$ 250,000
2	Bicentennial Park Shoreline Stabilization - Phase I	B-30293	\$ 7,194,024	\$ 5,670,357	\$ 1,523,667	\$ 5,670,357	\$ -
2	Bicentennial Park Shoreline Stabilization - Phase II	B-30290	\$ 3,810,395	\$ 2,309,952	\$ 1,500,443	\$ 2,309,952	\$ -
2	Bicentennial Park Shoreline Stabilization - Phase III	B-30310	\$ 5,982,074	\$ 1,788,428	\$ 4,193,646	\$ 1,788,428	\$ -
2	Billy Rolle Mini Park Shelter and Restroom Renovation	B-75822	\$ 50,000	\$ 50,000	\$ -	\$ -	\$ 50,000
2	Biscayne Park Site Improvements	B-75823	\$ 150,000	\$ 150,000	\$ -	\$ -	\$ 150,000
2	Blanche Park New Dog Park Fence	B-39910A	\$ 5,865	\$ 5,865	\$ -	\$ 5,865	\$ -
2	Blanche Park Site Improvements	B-75830	\$ 45,000	\$ 45,000	\$ -	\$ -	\$ 45,000
2	Brickell Avenue Decorative Pedestrian Crosswalk	B-39910I	\$ 23,000	\$ 23,000	\$ -	\$ -	\$ 23,000
2	Brickell Avenue Park Land Acquisition	B-30685	\$ 2,587,775	\$ 500,000	\$ 2,087,775	\$ -	\$ 500,000
2	Brickell Streetscape Project	B-40666	\$ 1,312,178	\$ 225,000	\$ 1,087,178	\$ 225,000	\$ -
2	Brickell Village Improvements	B-30176	\$ 400,000	\$ 400,000	\$ -	\$ 400,000	\$ -
2	City Cemetery Saunder's Plot Repairs	B-39910B	\$ 7,898	\$ 7,898	\$ -	\$ 7,898	\$ 0
2	City of Miami D/town Paramics Simul Model (Rev)	B-71209C	\$ 212,097	\$ 212,097	\$ -	\$ 212,097	\$ -
2	Coconut Grove Village Center Lighting	B-50593	\$ 397,168	\$ 202,687	\$ 194,481	\$ 202,687	\$ -

HOMELAND DEFENSE / NEIGHBORHOOD IMPROVEMENT BOND PROGRAM

DIST (S)	PROJECT NAME	PROJECT NO.	TOTAL PROJECT ALLOCATION	TOTAL HD ALLOCATION	OTHER SOURCES ALLOCATION	TOTAL HD INVOICED TO DATE	HD UNSPENT
2	Coconut Grove Village Kiosks	B-30590	\$ 221,980	\$ 221,980	\$ -	\$ 221,980	\$ -
2	Coconut Grove Waterfront Master Plan	B-30182	\$ 600,000	\$ 250,000	\$ 350,000	\$ 250,000	\$ -
2	Commodore Plaza Street Furniture Project	B-50593A	\$ 4,731	\$ 2,731	\$ 2,000	\$ 2,731	\$ -
2	Design District/FEC Corridor - Various Projects	B-38501	\$ 98,816	\$ 98,816	\$ -	\$ 98,816	\$ -
2	Dinner Key Dredging	B-30247	\$ 1,967,100	\$ 1,577,100	\$ 390,000	\$ 278,604	\$ 1,298,496
2	Dinner Key Dredging - Mitigation	B-30247A	\$ 332,900	\$ 332,900	\$ -	\$ 235,872	\$ 97,028
2	Dinner Key Marina Fuel Dock	B-60465	\$ 218,031	\$ 75,603	\$ 142,428	\$ 75,603	\$ -
2	Dinner Key Mooring Field Project	B-33511	\$ 1,295,586	\$ 468,341	\$ 827,245	\$ 407,877	\$ 60,464
2	District 2 Quality of Life Park Improvements	B-39910E	\$ 560,000	\$ 560,000	\$ -	\$ 448,856	\$ 111,144
2	DKM Pier 3 Emergency Repairs	B-30562	\$ 241,140	\$ 60,784	\$ 180,356	\$ 2,939	\$ 57,845
2	Dorsey Park Building Renovation Expansion	B-75840	\$ 576,886	\$ 576,886	\$ -	\$ 520,433	\$ 56,453
2	Douglas Park Recreation Building Renovations	B-60475	\$ 63,549	\$ 51,689	\$ 11,860	\$ 51,689	\$ -
2	Downtown Baywalk Master Plan & Design	B-30179	\$ 450,000	\$ 450,000	\$ -	\$ -	\$ 450,000
2	Downtown Infrastructure Improv.-One Miami	B-39901	\$ 4,304,843	\$ 4,304,843	\$ -	\$ 4,304,843	\$ -
2	DuPont Plaza Traffic Circ. PD&E Study Review	B-71209A	\$ 67,298	\$ 67,298	\$ -	\$ 67,298	\$ -
2	Fire Station #13	B-60453A	\$ 5,388,046	\$ 5,077,992	\$ 310,054	\$ 366,403	\$ 4,711,589
2	Fire Station #13 (New) - LAND ACQUISITION	B-60453	\$ 2,103,171	\$ 2,102,221	\$ 950	\$ 2,102,221	\$ -
2	Gateways for I-95 and I-395	B-30232	\$ 504,744	\$ 157,636	\$ 347,108	\$ 157,636	\$ -
2	Grand Avenue Improvements - Extension from Mary to Matilda	B-30322	\$ 175,217	\$ 146,382	\$ 28,835	\$ 130,054	\$ 16,328
2	Grand Avenue Landscape Lighting	B-30574	\$ 1,173,500	\$ 1,173,500	\$ -	\$ 935,704	\$ 237,796
2	Grand Avenue Streetscape Project	B-40680	\$ 4,248,897	\$ 1,399,364	\$ 2,849,533	\$ 1,399,364	\$ -
2	Gusman Hall Improvements	B-30546	\$ 2,425,000	\$ 825,000	\$ 1,600,000	\$ 825,000	\$ -
2	Historic Preservation Initiatives - Gusman Hall	B-78510	\$ 500,000	\$ 500,000	\$ -	\$ 500,000	\$ -
2	Kennedy Park Restroom Building Improvements	B-35838	\$ 625,900	\$ 600,000	\$ 25,900	\$ -	\$ 600,000
2	Kirk Munroe Tennis Court Improvements	B-75854	\$ 143,057	\$ 70,000	\$ 73,057	\$ -	\$ 70,000
2	Legion Park Parking Lot Renovation	B-35843	\$ 70,000	\$ 70,000	\$ -	\$ -	\$ 70,000
2	Legion Park Site Furnishings	B-75856	\$ 55,000	\$ 55,000	\$ -	\$ -	\$ 55,000
2	Margaret Pace Park Improvements - Phase II	B-35896	\$ 549,764	\$ 114,443	\$ 435,321	\$ 114,443	\$ -

HOMELAND DEFENSE /NEIGHBORHOOD IMPROVEMENT BOND PROGRAM

DIST (s)	PROJECT NAME	PROJECT NO.	TOTAL PROJECT ALLOCATION	TOTAL HD ALLOCATION	OTHER SOURCES ALLOCATION	TOTAL HD INVOICED TO DATE	HD UNSPENT
2	Marine Stadium Marina - Boat Rack Metal Roof Deck Replacement	B-33514D	\$ 150,000	\$ 150,000	\$ -	\$ 129,653	\$ 20,347
2	Marine Stadium Marina - Building Repairs	B-60463	\$ 45,859	\$ 516	\$ 45,343	\$ 516	\$ -
2	Marine Stadium Marina Improvements	B-33514	\$ 385,645	\$ 308,775	\$ 76,870	\$ 24,346	\$ 284,429
2	Marine Stadium Marina New Fuel Tank & Disposal	B-30225	\$ 65,000	\$ 65,000	\$ -	\$ 60,496	\$ 4,504
2	Marine Stadium Restoration	B-30688	\$ 175,000	\$ 175,000	\$ -	\$ -	\$ 175,000
2	Marjorie Stoneman Douglas Park Site Improvements	B-75862	\$ 60,000	\$ 60,000	\$ -	\$ 31,425	\$ 28,575
2	Merrie Christmas Park Site Improvements	B-75864	\$ 60,000	\$ 60,000	\$ -	\$ 42,633	\$ 17,367
2	Miamarina Dockmaster Bldg 2nd Floor A/C	B-60462	\$ 15,213	\$ 15,213	\$ -	\$ 15,213	\$ -
2	Miamarina Emergency Pier Repairs	B-30325	\$ 1,675,735	\$ 1,097,530	\$ 578,205	\$ 1,095,146	\$ 2,384
2	Miamarina Improvements	B-33513	\$ 21,826	\$ 21,826	\$ -	\$ 21,826	\$ -
2	Miami High School Bungalow Relo/Stabilization	B-3290A	\$ 427,439	\$ 251,088	\$ 176,351	\$ 251,088	\$ -
2	Miami River Tun. Feasibility Study-Traf. Simulation	B-71209B	\$ 73,451	\$ 29,116	\$ 44,335	\$ 29,116	\$ -
2	Miami Watersports Center - Hangar Improvements	B-35855	\$ 533,428	\$ 49,478	\$ 483,950	\$ 49,478	\$ -
2	MiMo BIC - Bid Implementation	B-39910H	\$ 100,000	\$ 100,000	\$ -	\$ 87,833	\$ 12,167
2	Morningside Park Recreation Building Improvements	B-35846	\$ 65,326	\$ 65,326	\$ -	\$ 65,326	\$ -
2	Morningside Park Restrooms Remodeling	B-35846A	\$ 562,120	\$ 562,120	\$ -	\$ 68,100	\$ 494,020
2	Morningside Park Shoreline Stabilization Project	B-30317	\$ 829,752	\$ 652,074	\$ 177,678	\$ 652,074	\$ -
2	Museum of Science-Contrib. to Park Mast. Plan	B-30169	\$ 700,000	\$ 700,000	\$ -	\$ 700,000	\$ -
2	Myers Park Ramp Security Lights	B-60297	\$ 35,500	\$ 29,523	\$ 5,977	\$ 29,523	\$ -
2	New Dinner Key Marina Dockmaster Building	B-60464	\$ 3,446,440	\$ 3,291,151	\$ 155,289	\$ 4,662	\$ 3,286,489
2	North Venetian Drive Lighting (District 2 QOL)	B-39910C	\$ 100,000	\$ 100,000	\$ -	\$ -	\$ 100,000
2	Old Miami High restoration	B-30532	\$ 416,157	\$ 60,157	\$ 356,000	\$ 60,157	\$ -
2	Pace Park Improvements	B-30079	\$ 2,151,476	\$ 1,645,375	\$ 506,101	\$ 1,645,375	\$ -
2	Parks ADA Modifications - District 2	B-30547E	\$ 215,347	\$ 215,347	\$ -	\$ 85,617	\$ 129,730
2	Paul S Walker Park	B-39910D	\$ 399,337	\$ 149,337	\$ 250,000	\$ 149,337	\$ -
2	Peacock Park Site Improvements	B-75883	\$ 800,124	\$ 800,000	\$ 124	\$ 526	\$ 799,474
2	Plaza Street ROW Landscape	B-30327	\$ 65,377	\$ 65,377	\$ -	\$ 65,377	\$ -
2	Police HQ Restrooms Rehab. & ADA Upgrade - Phase II	B-30219	\$ 537,010	\$ 502,010	\$ 35,000	\$ 502,010	\$ -

HOMELAND DEFENSE /NEIGHBORHOOD IMPROVEMENT BOND PROGRAM

DIST (s)	PROJECT NAME	PROJECT NO.	TOTAL PROJECT ALLOCATION	TOTAL HD ALLOCATION	OTHER SOURCES ALLOCATION	TOTAL HD INVOICED TO DATE	HD UNSPENT
2	Quality of Life District 2 - Various Projects	B-39910	\$ 1,853,238	\$ 1,853,238	\$ -	\$ 47,942	\$ 1,805,296
2	Roberto Clemente Park Bldg. Improvements	B-30172	\$ 254,752	\$ 251,462	\$ 3,290	\$ 251,462	\$ -
2	Roberto Clemente Park Recreation Building	B-30172A	\$ 2,731,158	\$ 2,731,158	\$ -	\$ 2,079,357	\$ 651,801
2	Roberto Clemente Park Waterplay Area	B-30311	\$ 155,926	\$ 98,106	\$ 57,820	\$ 98,106	\$ -
2	Simpson Park "Green Project" (District 2 QOL)	B-39910G	\$ 220,000	\$ 220,000	\$ -	\$ 220,000	\$ -
2	Simpson Park Wood Trail	B-60319	\$ 45,779	\$ 30,564	\$ 15,215	\$ 30,564	\$ -
2	South Miami Avenue Improvements	B-60479	\$ 6,782,508	\$ 294,198	\$ 6,488,310	\$ 294,198	\$ -
2	Virginia Key Bch Park/Renovations/Repairs-PH I	B-30281	\$ 1,202,132	\$ 259,509	\$ 942,623	\$ 259,509	\$ -
2	Virginia Key Beach North Point Mountain Bike Trails	B-30184A	\$ 11,646	\$ 11,646	\$ -	\$ -	\$ 11,646
2	Virginia Key Beach Park Circ. Rd & Prkg Improv.	B-30184	\$ 3,283,230	\$ 3,283,230	\$ -	\$ 3,283,230	\$ -
2	Virginia Key Beach Park Historic Restoration Phase 2	B-30174	\$ 1,306,765	\$ 1,046,765	\$ 260,000	\$ 652,080	\$ 394,685
2	Virginia Key Beach Park Master Plans	B-30164	\$ 371,722	\$ 371,722	\$ -	\$ 368,330	\$ 3,393
2	Virginia Key Beach Park Museum	B-30508	\$ 20,527,127	\$ 27,127	\$ 20,500,000	\$ 22,790	\$ 4,337
2	Virrick Park Com. Center-Library & Classroom	B-30292	\$ 1,145,982	\$ 645,982	\$ 500,000	\$ 645,982	\$ -
2	Virrick Park New Pool Facility	B-35853A	\$ 1,932,401	\$ 1,632,401	\$ 300,000	\$ 18,926	\$ 1,613,475
2	Virrick Park Pool Facility Renovation	B-35853	\$ 35,095	\$ 35,095	\$ -	\$ 35,095	\$ -
3	Calle Ocho Improvements	B-78509	\$ 442,469	\$ 397,469	\$ 45,000	\$ 345,282	\$ 52,187
3	Calle Ocho Improvements	B-78509A	\$ 778,372	\$ 778,372	\$ -	\$ -	\$ 778,372
3	Calle Ocho Improvements: Tower Theater Parking Lot Expansion	B-35005	\$ 374,413	\$ 374,413	\$ -	\$ 374,413	\$ -
3	Calle Ocho Landscaping Improvements	B-30345	\$ 390,516	\$ 67,938	\$ 322,578	\$ 59,571	\$ 8,367
3	Cuban Memorial Boulevard	B-30309	\$ 4,447,936	\$ 4,352,423	\$ 95,513	\$ 4,352,423	\$ -
3	Domino Park Expansion and Improvements Project	B-30289	\$ 562,386	\$ 898	\$ 561,488	\$ 898	\$ -
3	Emerg Repairs for Pole Lights @ Jose Marti Park	B-60507	\$ 7,580	\$ 7,580	\$ -	\$ 7,580	\$ -
3	Glenroyal Parkway Enhancements	B-30230	\$ 327,000	\$ 93,189	\$ 233,811	\$ 93,189	\$ -
3	Grove Mini-Park Playground	B-75891	\$ 35,004	\$ 21,703	\$ 13,301	\$ 21,703	\$ -
3	Henderson Park Court Upgrade	B-75894	\$ 29,874	\$ 29,874	\$ -	\$ 29,874	\$ -
3	Henderson Park New Bathroom Building	B-35856	\$ 32,879	\$ 32,879	\$ -	\$ 32,879	\$ -
3	Henderson Park New Office / Restroom Facility	B-35856A	\$ 1,284,069	\$ 305,069	\$ 979,000	\$ 250,751	\$ 54,318

HOMELAND DEFENSE / NEIGHBORHOOD IMPROVEMENT BOND PROGRAM

DIST (s)	PROJECT NAME	PROJECT NO.	TOTAL PROJECT ALLOCATION	TOTAL HD ALLOCATION	OTHER SOURCES ALLOCATION	TOTAL HD INVOICED TO DATE	HD UNSPENT
3	Jose Marti Field Restroom Renovation	B-30601	\$ 248,830	\$ 225,603	\$ 23,227	\$ 130,398	\$ 95,205
3	Jose Marti Park Gym	B-35857	\$ 11,265,431	\$ 7,884,739	\$ 3,380,692	\$ 7,699,492	\$ 185,248
3	Jose Marti Park Lighting	B-75903	\$ 161,201	\$ 115,147	\$ 46,054	\$ 115,147	\$ -
3	Jose Marti Park Playground Equipment	B-75895	\$ 103,840	\$ 95,090	\$ 8,750	\$ 95,090	\$ -
3	Jose Marti Park Site Furnishings	B-75899	\$ 64,074	\$ 64,074	\$ -	\$ 64,074	\$ -
3	Jose Marti Recreation Building	B-30258	\$ 1,906,138	\$ 823,436	\$ 1,082,702	\$ 823,436	\$ -
3	Maximo Gomez / Domino Park Restroom	B-35861A	\$ 264,138	\$ 222,040	\$ 42,098	\$ 34,976	\$ 187,064
3	Maximo Gomez/Domino Park Site Furnishings	B-75907	\$ 26,496	\$ 20,396	\$ 6,100	\$ 20,396	\$ -
3	Maximo Gomez/Domino Restroom Improvements	B-35861	\$ 1,520	\$ 1,520	\$ -	\$ 1,520	\$ -
3	Miami Greenway - Segment E1 - Neoloft	B-40707	\$ 374,548	\$ 338,720	\$ 35,828	\$ 338,720	\$ -
3	Miami River Greenway Streetscape Project - Segment E2	B-40693	\$ 631,064	\$ 354,435	\$ 276,629	\$ 354,435	\$ -
3	Miami River Greenway Streetscape Project - Segment F	B-40694	\$ 367,035	\$ 111,521	\$ 255,514	\$ 111,521	\$ -
3	Miami River Greenways/ Streetscape Segment D (ELH)	B-40686	\$ 5,088,500	\$ 478,216	\$ 4,610,284	\$ 3,948	\$ 474,268
3	Miami River Greenways/Streetscape E2/NeoLofts	B-40684	\$ 518	\$ 518	\$ -	\$ 518	\$ -
3	Neighborhood Gateways - Beacom Blvd	B-30143	\$ 58,005	\$ 58,005	\$ -	\$ 58,005	\$ -
3	Neighborhood Gateways - District 3	B-30143A	\$ 24,680	\$ 24,680	\$ -	\$ -	\$ 24,680
3	Orange Bowl Demolition	B-30153F	\$ 3,412,313	\$ 11,808	\$ 3,400,505	\$ 11,808	\$ -
3	Orange Bowl Press Box Roof Repair	B-30367	\$ 14,193	\$ 14,193	\$ -	\$ 14,193	\$ -
3	Orange Bowl Stad. Pressbox A/C Repl.- Design	B-30283	\$ 13,102	\$ 13,102	\$ -	\$ 13,102	\$ -
3	Orange Bowl Stadium - Remedial Structural Repairs	B-30269	\$ 676,311	\$ 50,000	\$ 626,311	\$ 50,000	\$ -
3	Orange Bowl Stadium Critical Repairs	B-30153D	\$ 430,719	\$ 430,719	\$ -	\$ 430,718	\$ 1
3	Orange Bowl Stadium Field Replacement	B-33516	\$ 108,583	\$ 108,583	\$ -	\$ 108,583	\$ -
3	Orange Bowl Stadium Lighting Towers No. 2, 3, 4, 5, 6, 7 & 8 Repairs	B-30379	\$ 1,973,799	\$ 1,180,525	\$ 793,274	\$ 1,180,525	\$ -
3	Orange Bowl Stadium New Safety Panels	B-60425	\$ 339,110	\$ 339,110	\$ -	\$ 339,110	\$ -
3	Orange Bowl Stadium Security Railings	B-60424	\$ 170,150	\$ 170,150	\$ -	\$ 170,150	\$ -
3	Orange Bowl Stadium Structural Repairs	B-30297	\$ 7,268,880	\$ 7,267,100	\$ 1,780	\$ 7,267,100	\$ -
3	Orange Bowl Stadium Structural Repairs	B-60373	\$ 2,111,768	\$ 610,000	\$ 1,501,768	\$ 610,000	\$ -
3	Orange Bowl Sta-Project Management Svcs	B-30153	\$ 3,505,674	\$ 3,505,674	\$ -	\$ 3,505,674	\$ -

HOMELAND DEFENSE / NEIGHBORHOOD IMPROVEMENT BOND PROGRAM

DIST (s)	PROJECT NAME	PROJECT NO.	TOTAL PROJECT ALLOCATION	TOTAL HD ALLOCATION	OTHER SOURCES ALLOCATION	TOTAL HD INVOICED TO DATE	HD UNSPENT
3	Parks ADA Modifications - District 3 - Jose Marti Park	B-30547F	\$ 96,917	\$ 96,917	\$ -	\$ 44,216	\$ 52,701
3	Riverside Park Court Upgrade	B-75913	\$ 7,960	\$ 7,960	\$ -	\$ 7,960	\$ -
3	Roads Neighborhood Traffic Calming	B-40671	\$ 2,607,669	\$ 599,292	\$ 2,008,377	\$ 599,292	\$ -
3	South Substation Security Gates	B-72923	\$ 59,500	\$ 40,000	\$ 19,500	\$ 40,000	\$ -
3	Southside Park Court Upgrade	B-75917	\$ 5,450	\$ 5,450	\$ -	\$ 5,450	\$ -
3	Southside Park Playground Equipment	B-75916	\$ 25,663	\$ 594	\$ 25,069	\$ 594	\$ -
3	SW 10 Road Enhancements	B-39909	\$ 228,118	\$ 218,819	\$ 9,299	\$ 218,819	\$ -
3	The Roads: Community Signs - D3	B-30650	\$ 10,485	\$ 10,485	\$ -	\$ 10,485	\$ -
3	Triangle Park Court Upgrade	B-75918	\$ 3,800	\$ 3,800	\$ -	\$ 3,800	\$ -
3	Triangle Park Fence Replacement	B-30071	\$ 33,865	\$ 33,865	\$ -	\$ 33,865	\$ -
3	Triangle Park Playgrounds	B-75919	\$ 10,284	\$ 10,284	\$ -	\$ 10,284	\$ -
4	Bay of Pigs Park Playground & Site Furnishing	B-75920	\$ 17,912	\$ 17,912	\$ -	\$ 17,912	\$ -
4	Bryan Park Interior Improvements	B-30302	\$ 122,073	\$ 122,073	\$ -	\$ 122,073	\$ -
4	Bryan Park New Tennis Center	B-30134	\$ 104,977	\$ 90,301	\$ 14,676	\$ 90,301	\$ -
4	Bryan Park New Tennis/Community Center	B-30134A	\$ 627	\$ 627	\$ -	\$ 627	\$ -
4	Bryan Park Right-Of-Way Improvements	B-30303	\$ 143,832	\$ 32,908	\$ 110,924	\$ 32,908	\$ -
4	Bryan Park Tennis Courts	B-30072	\$ 8,900	\$ 8,900	\$ -	\$ 8,900	\$ -
4	Bryan Park Tennis Courts Wind Screens	B-30073	\$ 13,595	\$ 12,458	\$ 1,137	\$ 12,458	\$ -
4	Calle Ocho Beautification Improvements - East of 37 Ave.	B-30222	\$ 166,789	\$ 166,789	\$ -	\$ 166,789	\$ -
4	Calle Ocho Beautification - East of 37 Ave	B-30222A	\$ 909,445	\$ 909,445	\$ -	\$ -	\$ 909,445
4	Coral Gate Park Building Improvements	B-35865	\$ 57,342	\$ 51,047	\$ 6,295	\$ 51,047	\$ -
4	Coral Gate Park Community Building	B-35865A	\$ 1,138,180	\$ 1,063,180	\$ 75,000	\$ 76,572	\$ 986,608
4	Coral Gate Park Site Furnishings	B-75925	\$ 66,541	\$ 57,429	\$ 9,111	\$ 57,429	\$ -
4	Curb Replacement - Phase 2	B-30338A	\$ 97,371	\$ 49,395	\$ 47,976	\$ 49,395	\$ -
4	District 4 Curb Replacement	B-30338	\$ 250,605	\$ 250,605	\$ -	\$ 250,604	\$ 1
4	Fairlawn Storm Sewer Improvements Project Phase III	B-50704	\$ 5,363,826	\$ 1,435,000	\$ 3,928,826	\$ 566,461	\$ 868,539
4	Fire Station #11 (New)	B-60452	\$ 5,782,043	\$ 5,208,047	\$ 573,996	\$ 2,719,795	\$ 2,488,252
4	Fire Station #14 (New)	B-60454	\$ 4,837,442	\$ 312,442	\$ 4,525,000	\$ 181,362	\$ 131,080

HOMELAND DEFENSE / NEIGHBORHOOD IMPROVEMENT BOND PROGRAM

DIST (s)	PROJECT NAME	PROJECT NO.	TOTAL PROJECT ALLOCATION	TOTAL HD ALLOCATION	OTHER SOURCES ALLOCATION	TOTAL HD INVOICED TO DATE	HD UNSPENT
4	Flagami Neighborhood Traffic Calming Improvements (Phase I)	B-40672	\$ 949,061	\$ 595,666	\$ 353,395	\$ 595,666	\$ -
4	Parks ADA Modifications - District 4	B-30547G	\$ 91,147	\$ 91,147	\$ -	\$ 25,803	\$ 65,344
4	Robert King High Park New Bldg Const	B-35868	\$ 3,039,939	\$ 2,689,938	\$ 350,001	\$ 228,634	\$ 2,461,304
4	Robert King High Park Soccer Field Restrooms	B-30229	\$ 1,386,313	\$ 1,386,313	\$ -	\$ 162,870	\$ 1,223,443
4	Shenandoah Park Improvements	B-30304	\$ 2,635,184	\$ 2,594,667	\$ 40,517	\$ 1,265,815	\$ 1,328,852
4	Shenandoah Traffic Calming (Study Only)	B-30006	\$ 49,879	\$ 49,879	\$ -	\$ 49,879	\$ -
4	Silver Bluff Traffic Calming - Phase 1 - D4	B-30168	\$ 1,314,033	\$ 74,033	\$ 1,240,000	\$ 74,033	\$ -
4	Silver Bluff Traffic Calming (Study Only)	B-30003	\$ 49,962	\$ 49,962	\$ -	\$ 49,962	\$ -
4	SW 11 Street Reconstruction Project	B-50699	\$ 105,365	\$ 105,365	\$ -	\$ 105,365	\$ -
4	SW 16 Terrace Road Reconstruction Project	B-40698	\$ 1,302,185	\$ 1,061,500	\$ 240,685	\$ 1,061,500	\$ -
4	SW 22 Terrace Improvements - The Aston	B-39907	\$ 188,623	\$ 188,623	\$ -	\$ 188,623	\$ -
4	Water Truck Acquisition	B-30163	\$ 99,500	\$ 99,500	\$ -	\$ 99,500	\$ -
4	West End Park Building Terrace Remodeling	B-30224	\$ 112,034	\$ 112,034	\$ -	\$ 112,034	\$ -
4	West End Park Playground Equipment	B-75932	\$ 160,000	\$ 160,000	\$ -	\$ 160,000	\$ -
4	West End Park Pool Improvements	B-35871	\$ 656,689	\$ 656,689	\$ -	\$ 656,689	\$ -
4	West Little Havana, Home Depot Area Traffic Circles	B-30235A	\$ 626,737	\$ 100,000	\$ 526,737	\$ 100,000	\$ -
5	African Square Court Upgrades	B-75938	\$ 3,760	\$ 3,760	\$ -	\$ 3,760	\$ -
5	African Square Park Rec. Bldg. Improvements	B-35872	\$ 183,240	\$ 183,240	\$ -	\$ -	\$ 183,240
5	Athalie Range #1 Mini Park Improvements	B-30291	\$ 331,697	\$ 300,000	\$ 31,697	\$ 88,864	\$ 211,136
5	Athalie Range Park Court Upgrades	B-75979	\$ 54,718	\$ 54,718	\$ -	\$ 54,718	\$ -
5	Athalie Range Park Playground Equipment	B-75976	\$ 49,849	\$ 49,849	\$ -	\$ 49,849	\$ -
5	Athalie Range Park Pool Improvements	B-35889A	\$ 680,699	\$ 201,924	\$ 478,775	\$ 201,924	\$ -
5	Athalie Range Park Soccer / Football Field Improvements	B-35907	\$ 2,676,251	\$ 2,176,251	\$ 500,000	\$ 258,240	\$ 1,918,011
5	Athalie Range Park Swimming Pool Improvements	B-35889	\$ 1,468,733	\$ 1,468,733	\$ -	\$ 1,468,733	\$ -
5	Belafonte Tacolcy Center Roof	B-35873	\$ 23,880	\$ 23,880	\$ -	\$ 23,880	\$ -
5	Belafonte Tacolcy Center Site Improvements	B-35908	\$ 75,011	\$ 66,309	\$ 8,702	\$ 66,309	\$ -
5	Belafonte Tacolcy Park Court Upgrades	B-75943	\$ 20,732	\$ 20,732	\$ -	\$ 20,732	\$ -
5	Belafonte Tacolcy Park Irrigation	B-30109	\$ 1,835	\$ 1,835	\$ -	\$ 1,835	\$ -

HOMELAND DEFENSE /NEIGHBORHOOD IMPROVEMENT BOND PROGRAM

DIST (s)	PROJECT NAME	PROJECT NO.	TOTAL PROJECT ALLOCATION	TOTAL HD ALLOCATION	OTHER SOURCES ALLOCATION	TOTAL HD INVOICED TO DATE	HD UNSPENT
5	Black Police Precinct/ Museum / Employee Training	B-30299A	\$ 31,977	\$ 31,977	\$ -	\$ 31,977	\$ -
5	Black Police Precinct/Courthouse Museum Restoration	B-30299	\$ 2,325,931	\$ 1,722,986	\$ 602,945	\$ 1,722,986	\$ -
5	Brentwood Village Project	B-40665	\$ 800,000	\$ 800,000	\$ -	\$ 100,908	\$ 699,092
5	Buena Vista East Historic District - Streetscape Improvements PH_2	B-78500A	\$ 2,381,585	\$ 403,621	\$ 1,977,964	\$ 403,621	\$ -
5	Buena Vista East Historic District- Streetscape Improvements PH_1	B-78500	\$ 1,503,017	\$ 1,470,865	\$ 32,152	\$ 1,470,865	\$ -
5	Buena Vista Heights - Ph.I	B-40699	\$ 1,183,280	\$ 1,031,528	\$ 151,753	\$ 1,031,528	\$ -
5	Buena Vista Park Court Upgrades	B-75947	\$ 10,000	\$ 10,000	\$ -	\$ -	\$ 10,000
5	Buena Vista Park Playground Equipment	B-75945	\$ 15,000	\$ 15,000	\$ -	\$ -	\$ 15,000
5	Buena Vista Park Site Furnishings	B-75946	\$ 5,000	\$ 5,000	\$ -	\$ -	\$ 5,000
5	Eaton Park Fence	B-75951	\$ 20,292	\$ 20,292	\$ -	\$ 20,292	\$ -
5	Eaton Park Playground Site Furnishings	B-75950	\$ 33,937	\$ 33,937	\$ -	\$ 33,937	\$ -
5	Gibson Park Improvements	B-30305	\$ 1,978,028	\$ 1,527,375	\$ 450,653	\$ 1,527,375	\$ -
5	Gibson Park New Construction	B-30305B	\$ 9,939,521	\$ 97,774	\$ 9,841,747	\$ 44	\$ 97,730
5	Gibson Pk Bldg Impr. Hur. Shut@Overtown YC	B-30076	\$ 28,550	\$ 28,550	\$ -	\$ 28,550	\$ -
5	Hadley Park Bathroom Flooring	B-30077	\$ 32,262	\$ 29,660	\$ 2,602	\$ 29,660	\$ -
5	Hadley Park Black Box AC Structure	B-30165	\$ 10,830	\$ 10,830	\$ -	\$ 10,830	\$ -
5	Hadley Park Court Upgrades	B-75958	\$ 29,090	\$ 29,090	\$ -	\$ 29,090	\$ -
5	Hadley Park Model City Trust Offices	B-60457	\$ 79,300	\$ 79,300	\$ -	\$ 79,300	\$ -
5	Hadley Park Pool Lockers	B-35886	\$ 18,985	\$ 18,985	\$ -	\$ 18,985	\$ -
5	Hadley Park Site Furnishings	B-75959	\$ 29,572	\$ 29,572	\$ -	\$ 29,572	\$ -
5	Hadley Park Swim Pool Htg/Cooling Syst	B-35897	\$ 127,620	\$ 127,620	\$ -	\$ 127,620	\$ -
5	Hadley Park Youth Center and Field Improvements	B-35883A	\$ 4,900,521	\$ 614,993	\$ 4,285,528	\$ 11,788	\$ 603,205
5	Lemon City Park Playground & Park Equipment	B-75963	\$ 108,716	\$ 13,092	\$ 95,624	\$ 13,092	\$ -
5	Lemon City Prk Security/B-ball Crt Lght Proj	B-60493	\$ 53,319	\$ 53,319	\$ -	\$ 53,319	\$ -
5	Little Haiti Freedom Garden	B-30198	\$ 40,361	\$ 3,495	\$ 36,866	\$ 3,495	\$ -
5	Little Haiti Park - Cultural Campus	B-30295	\$ 15,740,915	\$ 9,997,765	\$ 5,743,150	\$ 9,952,235	\$ 45,530
5	Little Haiti Park - Cultural Center Master Plan	B-30308A	\$ 29,799	\$ 29,799	\$ -	\$ 29,799	\$ -
5	Little Haiti Park - Cultural Ctr Master Plan	B-70850	\$ 27,500	\$ 27,500	\$ -	\$ 27,500	\$ -

HOMELAND DEFENSE / NEIGHBORHOOD IMPROVEMENT BOND PROGRAM

DIST (s)	PROJECT NAME	PROJECT NO.	TOTAL PROJECT ALLOCATION	TOTAL HD ALLOCATION	OTHER SOURCES ALLOCATION	TOTAL HD INVOICED TO DATE	HD UNSPENT
5	Little Haiti Park - Land Acquisition Activities	B-78511	\$ 11,132,781	\$ 10,551,281	\$ 581,500	\$ 10,551,281	\$ -
5	Little Haiti Park - Soccer and Community Center	B-38500	\$ 7,817,231	\$ 5,463,981	\$ 2,353,250	\$ 5,463,981	\$ -
5	Lummus Park - Police Stables	B-30320	\$ 1,435,447	\$ 1,418,719	\$ 16,728	\$ 1,418,719	\$ -
5	Lummus Park Recreation Building Improvement	B-75859	\$ 1,246,535	\$ 544,928	\$ 701,607	\$ 544,928	\$ -
5	Miami River Greenway Segment A - Lighting Installation	B-40690A	\$ 62,476	\$ 28,147	\$ 34,329	\$ 28,147	\$ -
5	Miami River Greenway Streetscape Project - Seg B	B-40691	\$ 1,127,728	\$ 72,450	\$ 1,055,278	\$ 72,450	\$ -
5	Miami River Greenway Streetscape Project - Seg C	B-40692	\$ 670,335	\$ 115,248	\$ 555,087	\$ 115,248	\$ -
5	Miami River Greenway Streetscape Project - Segment A	B-40690	\$ 860,469	\$ 172,222	\$ 688,247	\$ 172,222	\$ -
5	Model City Infrastructure - MLK Boulevard	B-78505	\$ 4,220,103	\$ 2,998,945	\$ 1,221,158	\$ 2,998,945	\$ -
5	Model City Infrastructure Improvements	B-78504	\$ 3,000,000	\$ 3,000,000	\$ -	\$ 2,576,314	\$ 423,686
5	Moore Park Court Upgrades	B-75970	\$ 55,640	\$ 55,640	\$ -	\$ 55,640	\$ -
5	Moore Park New Construction	B-35887	\$ 5,905,462	\$ 4,611,862	\$ 1,293,600	\$ 196,050	\$ 4,415,812
5	Moore Park Playground Equipment	B-75967	\$ 117,950	\$ 117,950	\$ -	\$ 117,950	\$ -
5	Moore Park Shade Structure	B-30074	\$ 86,900	\$ 80,000	\$ 6,900	\$ 80,000	\$ -
5	Moore Park Temporary Daycare Center Trailers	B-35887A	\$ 92,000	\$ 92,000	\$ -	\$ 19,850	\$ 72,150
5	Moore Park Track Resurfacing	B-75968	\$ 73,378	\$ 73,378	\$ -	\$ 73,378	\$ -
5	NE 40 Street Reconstruction	B-31207	\$ 2,227,744	\$ 1,771,414	\$ 456,330	\$ 1,771,414	\$ -
5	Neighborhood Gateways - District 5	B-30145	\$ 100,000	\$ 100,000	\$ -	\$ -	\$ 100,000
5	North Spring Garden Greenway	B-40643A	\$ 4,130,710	\$ 180,000	\$ 3,950,710	\$ 79,049	\$ 100,951
5	NW 58th Street and Swale Improvements	B-30392	\$ 45,959	\$ 45,959	\$ -	\$ 45,959	\$ -
5	Oakland Grove Park Playground Equipment	B-75973	\$ 15,000	\$ 15,000	\$ -	\$ -	\$ 15,000
5	Parks ADA Modifications - District 5	B-30547H	\$ 211,137	\$ 211,137	\$ -	\$ 72,881	\$ 138,256
5	Police HQ Shower Rehab & ADA upgrades	B-72926	\$ 554,924	\$ 519,596	\$ 35,328	\$ 519,596	\$ -
5	Reeves Park Building Renovations	B-35894	\$ 288,494	\$ 200,730	\$ 87,764	\$ 200,730	\$ -
5	Reeves Park Court Upgrades	B-75983	\$ 7,958	\$ 7,958	\$ -	\$ 7,958	\$ -
5	Reeves Park Playground Equipment	B-75982	\$ 78,601	\$ 78,601	\$ -	\$ 78,601	\$ -
5	Spring Garden Point Park Privacy Wall	B-30218	\$ 32,040	\$ 11,200	\$ 20,840	\$ 11,200	\$ -
5	Spring Garden Point Park Seybold Canal House Restoration	B-30273	\$ 32,500	\$ 12,500	\$ 20,000	\$ 12,500	\$ -

HOMELAND DEFENSE / NEIGHBORHOOD IMPROVEMENT BOND PROGRAM

DIST (s)	PROJECT NAME	PROJECT NO.	TOTAL PROJECT ALLOCATION	TOTAL HD ALLOCATION	OTHER SOURCES ALLOCATION	TOTAL HD INVOICED TO DATE	HD UNSPENT
5	Town Park Improvements	B-75985A	\$ 45,000	\$ 45,000	\$ -	\$ -	\$ 45,000
5	West Buena Vista Playground Equipment	B-75986	\$ 32,876	\$ 23,378	\$ 9,498	\$ 23,378	\$ -
5	Williams Park Community Building	B-75991A	\$ 2,388,570	\$ 1,738,570	\$ 650,000	\$ 111,827	\$ 1,626,743
5	Williams Park Improvements	B-75991	\$ 107,643	\$ 107,643	\$ -	\$ 107,643	\$ -
5	Williams Park Irrigation/Landscaping	B-75993	\$ 31,800	\$ 31,800	\$ -	\$ 31,800	\$ -
5	Williams Park Playground Equipment	B-75988	\$ 278,026	\$ 267,298	\$ 10,729	\$ 267,298	\$ -
5	Williams Park Site Furnishings	B-75995	\$ 145,230	\$ 23,600	\$ 121,630	\$ 23,600	\$ -
1,4	Kinloch Storm Sewer Improvements Project	B-50705	\$ 4,009,233	\$ 3,189,000	\$ 820,233	\$ 606,809	\$ 2,582,191
1,4	Tamiami Storm Sewer Improvements Project	B-50706	\$ 3,010,000	\$ 2,811,000	\$ 199,000	\$ 1,634,775	\$ 1,176,225
2,3	Downtown and Brickell Area Traffic Operations	B-71209	\$ 33,595	\$ 33,595	\$ -	\$ 33,595	\$ -
2,4	Citywide Curb Replacement Project	B-40661	\$ 332,592	\$ 269,930	\$ 62,662	\$ 269,930	\$ -
2,5	Design District/FEC series 2 Balance (SWAP)	B-30178	\$ 1,800,000	\$ 1,800,000	\$ -	\$ -	\$ 1,800,000
2,5	Downtown Infrastructure Streets - Phase II	B-30177	\$ 2,856,598	\$ 51,229	\$ 2,805,369	\$ 51,229	\$ -
2,5	Downtown Infrastructure Streets Phase I	B-39902	\$ 4,226,707	\$ 4,226,707	\$ -	\$ 4,226,707	\$ -
2,5	NE 2 Avenue Improvements	B-78508	\$ 4,985,810	\$ 3,700,000	\$ 1,285,810	\$ 970,642	\$ 2,729,358
3,4	Citywide Sidewalk Replacement Phase 24	B-40664	\$ 1,002,917	\$ 500,000	\$ 502,918	\$ 200,000	\$ -
3,4	Coral Way Beautification - Phase II	B-60450	\$ 1,113,277	\$ 1,113,277	\$ -	\$ 1,113,277	\$ -
3,4	Coral Way Beautification Uplighting - Phase I	B-60451	\$ 912,976	\$ 859,595	\$ 53,381	\$ 859,595	\$ -
3,4	Shenandoah Traffic Calming - Phase 1	B-30167	\$ 1,780,500	\$ 103,500	\$ 1,677,000	\$ 103,500	\$ -
1,2,3, 4,5	City Hall Emergency Chattahoochee Removal	B-30655	\$ 2,022	\$ 2,022	\$ -	\$ 2,007	\$ 15
1,2,3, 4,5	City of Miami MMPD Fire Suppressor Mod's (FM200 System)	B-60437	\$ 524,394	\$ 73,894	\$ 450,500	\$ 73,459	\$ 435
1,2,3, 4,5	Citywide Park Equipment & Site Improvements	B-30541	\$ 5,073,147	\$ 931,583	\$ 4,141,564	\$ 402,125	\$ 529,458
1,2,3, 4,5	Citywide Traffic Circles D2, D3 and D4	B-30235	\$ 506,100	\$ 30,000	\$ 476,100	\$ -	\$ 30,000
1,2,3, 4,5	Communications Vehicle Acquisition	B-72814	\$ 167,751	\$ 167,751	\$ -	\$ 167,751	\$ -
1,2,3, 4,5	Cooling Tower Support Bracket - Replacement	B-30385	\$ 296,586	\$ 43,765	\$ 252,821	\$ -	\$ 43,765
1,2,3, 4,5	Defense and Security Equipment Acquisition	B-72813	\$ 3,767,249	\$ 3,767,249	\$ -	\$ 822,495	\$ 2,944,754
1,2,3, 4,5	Historic Preservation Development Initiative	B-78512	\$ 20,000	\$ 20,000	\$ -	\$ 20,000	\$ -
1,2,3, 4,5	Historic Preservation Development Initiative - Phase 2	B-78512A	\$ 37,500	\$ 37,500	\$ -	\$ 35,307	\$ 2,193

HOMELAND DEFENSE / NEIGHBORHOOD IMPROVEMENT BOND PROGRAM

DIST (s)	PROJECT NAME	PROJECT NO.	TOTAL PROJECT ALLOCATION	TOTAL HD ALLOCATION	OTHER SOURCES ALLOCATION	TOTAL HD INVOICED TO DATE	HD UNSPENT
1,2,3,4,5	Historic Preservation Initiatives - City Hall	B-30121	\$ 1,072,999	\$ 494,846	\$ 578,153	\$ 100,581	\$ 394,265
1,2,3,4,5	Homeland Defense Legal Services Support	B-30078	\$ 29,346	\$ 29,346	\$ -	\$ 29,346	\$ -
1,2,3,4,5	Miami River Greenway - Design Guidelines	B-40685	\$ 70,564	\$ 70,564	\$ -	\$ 70,564	\$ -
1,2,3,4,5	Museum of Art - Development in Bicentennial Park	B-78503	\$ 2,700,000	\$ 2,700,000	\$ -	\$ 2,700,000	\$ -
1,2,3,4,5	Museum of Science - Development in Bicentennial Park	B-78502	\$ 700,000	\$ 700,000	\$ -	\$ 700,000	\$ -
1,2,3,4,5	Museum of Science - Development in Bicentennial Park - Phase 2	B-78502A	\$ 2,000,000	\$ 2,000,000	\$ -	\$ 331,311	\$ 1,668,689
1,2,3,4,5	Museum Park	B-30538	\$ 6,242,000	\$ 100,000	\$ 6,142,000	\$ 100,000	\$ -
1,2,3,4,5	Museum Park Environmental Remediation	B-30538B	\$ 200,000	\$ 200,000	\$ -	\$ -	\$ 200,000
1,2,3,4,5	Neighborhood Parks Improvement - ADA Modifications	B-35904	\$ 6,023,189	\$ 6,023,189	\$ -	\$ -	\$ 6,023,189
1,2,3,4,5	Orange Bowl / Marlins Re-Development	B-30153J	\$ 7,358,883	\$ 374,359	\$ 6,984,524	\$ 4,498	\$ 369,862
1,2,3,4,5	Parks Master Plan	B-35895	\$ 657,850	\$ 657,850	\$ -	\$ 657,850	\$ -
1,2,3,4,5	Parks Master Plan - ADA Transition Plan	B-79901	\$ 190,250	\$ 190,250	\$ -	\$ 190,250	\$ -
1,2,3,4,5	Police Department Property Unit Outdoor Storage	B-30373A	\$ 870,931	\$ 116,235	\$ 754,696	\$ 81,552	\$ 34,683
1,2,3,4,5	Police Homeland Defense Preparedness Initiative	B-72911	\$ 818,596	\$ 818,596	\$ -	\$ 818,596	\$ -
1,2,3,4,5	Terrorist Cache Vehicle Acquisition	B-72815	\$ 564,577	\$ 564,577	\$ -	\$ 564,577	\$ -
1,2,3,4,5	The College of Policing	B-72910	\$ 40,276,037	\$ 22,031,435	\$ 18,244,602	\$ 21,990,229	\$ 41,206
1,2,3,4,5	Waterfront Improvements Citywide	B-39903	\$ 1,368,007	\$ 1,368,007	\$ -	\$ -	\$ 1,368,007
Totals			\$ 438,001,477	\$ 256,508,062	\$ 181,493,415	\$ 188,185,817	\$ 68,022,244

HOMELAND DEFENSE NEIGHBORHOOD IMPROVEMENT BOND PROGRAM

PROJECT NO.	PROJECT NAME	ORIGINAL HD BOND AMOUNT	TOTAL PROJECT ALLOCATION	TOTAL HD ALLOCATION	OTHER SOURCES ALLOCATION	TOTAL HD INVOICED TO DATE	HD UNSPENT
B-30169	Museum of Science-Contrib. to Park Mast. Plan		\$ 700,000.00	\$ 700,000.00	\$ -	\$ 700,000.00	\$ -
B-30538B	Museum Park Environmental Remediation		\$ 100,000.00	\$ 100,000.00	\$ -	\$ -	\$ 100,000.00
B-78502	Museum of Science - Development in Bicentennial Park		\$ 700,000.00	\$ 700,000.00	\$ -	\$ 700,000.00	\$ -
B-78502A	Museum of Science - Development in Bicentennial Park - Phase 2		\$ 2,000,000.00	\$ 2,000,000.00	\$ -	\$ 331,311.43	\$ 1,668,688.57
Total - Quality of Life - Museum of Science		\$ 3,500,000	\$ 3,500,000	\$ 3,500,000	\$ -	\$ 1,731,311	\$ 1,768,689
B-30170	Art Museum-Contribution to Park Master Plan		\$ 621,415.30	\$ 621,415.30	\$ -	\$ 621,415.30	\$ -
B-30538B	Museum Park Environmental Remediation		\$ 100,000.00	\$ 100,000.00	\$ -	\$ -	\$ 100,000.00
B-78503	Museum of Art - Development in Bicentennial Park		\$ 2,700,000.00	\$ 2,700,000.00	\$ -	\$ 2,700,000.00	\$ -
Total - Quality of Life - Miami Art Museum		\$ 3,500,000	\$ 3,421,415	\$ 3,421,415	\$ -	\$ 3,321,415	\$ 100,000
B-35857	Jose Marti Park Gym		\$ 167,826.43	\$ 167,826.43	\$ -	\$ 167,826.43	\$ -
B-40643A	North Spring Garden Greenway		\$ 4,130,710.00	\$ 180,000.00	\$ 3,950,710.00	\$ 79,048.92	\$ 100,951.08
B-40684	Miami River Greenways/Streetscape E2/NeoLofts		\$ 518.00	\$ 518.00	\$ -	\$ 518.00	\$ -
B-40685	Miami River Greenway - Design Guidelines		\$ 70,564.01	\$ 70,564.01	\$ -	\$ 70,564.01	\$ -
B-40686	Miami River Greenways/ Streetscape Segment D (ELH)		\$ 5,088,500.00	\$ 478,216.00	\$ 4,610,284.00	\$ 3,947.62	\$ 474,268.38
B-40690	Miami River Greenway Streetscape Project - Segment A		\$ 860,469.14	\$ 172,222.29	\$ 688,246.85	\$ 172,222.29	\$ -
B-40690A	Miami River Greenway Segment A - Lighting Installation		\$ 62,476.00	\$ 28,147.00	\$ 34,329.00	\$ 28,147.00	\$ -
B-40691	Miami River Greenway Streetscape Project - Seg B		\$ 1,127,728.00	\$ 72,450.00	\$ 1,055,278.00	\$ 72,450.00	\$ -
B-40692	Miami River Greenway Streetscape Project - Seg C		\$ 670,335.18	\$ 115,248.18	\$ 555,087.00	\$ 115,248.18	\$ -
B-40693	Miami River Greenway Streetscape Project - Segment E2		\$ 631,063.70	\$ 354,434.70	\$ 276,629.00	\$ 354,434.70	\$ -
B-40694	Miami River Greenway Streetscape Project - Segment F		\$ 367,035.00	\$ 111,521.00	\$ 255,514.00	\$ 111,521.00	\$ -
B-40707	Miami Greenway - Segment E1 - Neoloft		\$ 374,548.00	\$ 338,720.00	\$ 35,828.00	\$ 338,720.00	\$ -
Total - Quality of Life - Greenways Improvements		\$ 2,000,000	\$ 13,551,773	\$ 2,089,868	\$ 11,461,906	\$ 1,514,648	\$ 575,219
B-30141	Neighborhood Gateways - District 1		\$ 50,000.00	\$ 50,000.00	\$ -	\$ -	\$ 50,000.00
B-30143	Neighborhood Gateways - Beacom Blvd		\$ 58,004.90	\$ 58,004.90	\$ -	\$ 58,004.90	\$ -
B-30143A	Neighborhood Gateways - District 3		\$ 24,680.00	\$ 24,680.00	\$ -	\$ -	\$ 24,680.00
B-30145	Neighborhood Gateways - District 5		\$ 100,000.00	\$ 100,000.00	\$ -	\$ -	\$ 100,000.00
B-30650	The Roads: Community Signs - D3		\$ 10,485.12	\$ 10,485.12	\$ -	\$ 10,485.12	\$ -
Total - Quality of Life - Neighborhood Gateway		\$ 4,000,000	\$ 243,170	\$ 243,170	\$ -	\$ 68,490	\$ 174,680

HOMELAND DEFENSE NEIGHBORHOOD IMPROVEMENT BOND PROGRAM

PROJECT NO.	PROJECT NAME	ORIGINAL HD BOND AMOUNT	TOTAL PROJECT ALLOCATION	TOTAL HD ALLOCATION	OTHER SOURCES ALLOCATION	TOTAL HD INVOICED TO DATE	HD UNSPENT
B-30228	NW 19th Terrace		\$ 448,354.00	\$ 135,260.00	\$ 313,094.00	\$ 135,260.00	\$ -
B-50686	NW 14 Street Project		\$ 2,907,281.28	\$ 790,751.90	\$ 2,116,529.38	\$ 790,751.90	\$ -
B-60430	Antonio Maceo Park New Community Building		\$ 1,074,666.99	\$ 664,739.99	\$ 409,927.00	\$ 664,739.99	\$ -
B-60496	Grapeland Heights Park Site Development - Ph1		\$ 6,425,797.00	\$ 3,400,000.00	\$ 3,025,797.00	\$ 3,400,000.00	\$ -
Total - Quality of Life District 1		\$ 5,000,000	\$ 10,856,099	\$ 4,990,752	\$ 5,865,347	\$ 4,990,752	\$ -
B-30176	Brickell Village Improvements		\$ 400,000.00	\$ 400,000.00	\$ -	\$ 400,000.00	\$ -
B-30232	Gateways for I-95 and I-395		\$ 504,743.66	\$ 157,635.66	\$ 347,108.00	\$ 157,635.66	\$ -
B-30311	Roberto Clemente Park Waterplay Area		\$ 155,925.82	\$ 98,105.82	\$ 57,820.00	\$ 98,105.82	\$ -
B-30590	Coconut Grove Village Kiosks		\$ 221,979.60	\$ 221,979.60	\$ -	\$ 221,979.60	\$ -
B-39910	Quality of Life District 2 - Various Projects		\$ 1,853,238.00	\$ 1,853,238.00	\$ -	\$ 47,941.75	\$ 1,805,296.25
B-39910A	Blanche Park New Dog Park Fence		\$ 5,865.00	\$ 5,865.00	\$ -	\$ 5,865.00	\$ -
B-39910B	City Cemetery Saunder's Plot Repairs		\$ 7,898.00	\$ 7,898.00	\$ -	\$ 7,897.64	\$ 0.36
B-39910D	Paul S Walker Park		\$ 399,337.05	\$ 149,337.05	\$ 250,000.00	\$ 149,337.05	\$ -
B-39910E	District 2 Quality of Life Park Improvements		\$ 560,000.00	\$ 560,000.00	\$ -	\$ 448,855.59	\$ 111,144.41
B-39910G	Simpson Park "Green Project" (District 2 QOL)		\$ 220,000.00	\$ 220,000.00	\$ -	\$ 220,000.00	\$ -
B-39910H	MiMo BIC - Bid Implementation		\$ 100,000.00	\$ 100,000.00	\$ -	\$ 87,833.30	\$ 12,166.70
B-40661	Citywide Curb Replacement Project		\$ 190,123.00	\$ 190,123.00	\$ -	\$ 190,123.00	\$ -
B-60297	Myers Park Ramp Security Lights		\$ 35,499.68	\$ 29,522.68	\$ 5,977.00	\$ 29,522.68	\$ -
B-60319	Simpson Park Wood Trail		\$ 45,779.00	\$ 30,564.00	\$ 15,215.00	\$ 30,564.00	\$ -
B-60479	South Miami Avenue Improvements		\$ 6,782,508.01	\$ 294,198.01	\$ 6,488,310.00	\$ 294,198.01	\$ -
Total - Quality of Life District 2		\$ 5,000,000	\$ 11,482,897	\$ 4,318,467	\$ 7,164,430	\$ 2,389,859	\$ 1,928,608
B-30230	Glenroyal Parkway Enhancements		\$ 327,000.00	\$ 93,189.00	\$ 233,811.00	\$ 93,189.00	\$ -
B-30309	Cuban Memorial Boulevard		\$ 2,223,458.62	\$ 2,127,945.41	\$ 95,513.21	\$ 2,127,945.41	\$ -
B-39909	SW 10 Road Enhancements		\$ 228,117.92	\$ 218,818.92	\$ 9,299.00	\$ 218,818.92	\$ -
B-39910C	North Venetian Drive Lighting (District 2 QOL)		\$ 100,000.00	\$ 100,000.00	\$ -	\$ -	\$ 100,000.00
B-40664	Citywide Sidewalk Replacement Phase 24		\$ 401,166.60	\$ 199,999.60	\$ 201,167.00	\$ 199,999.60	\$ -
B-40671	Roads Neighborhood Traffic Calming		\$ 2,607,669.21	\$ 599,292.21	\$ 2,008,377.00	\$ 599,292.21	\$ -
Total - Quality of Life District 3		\$ 5,000,000	\$ 5,887,412	\$ 3,339,245	\$ 2,548,167	\$ 3,239,245	\$ 100,000

HOMELAND DEFENSE NEIGHBORHOOD IMPROVEMENT BOND PROGRAM

PROJECT NO.	PROJECT NAME	ORIGINAL HD BOND AMOUNT	TOTAL PROJECT ALLOCATION	TOTAL HD ALLOCATION	OTHER SOURCES ALLOCATION	TOTAL HD INVOICED TO DATE	HD UNSPENT
B-30003	Silver Bluff Traffic Calming (Study Only)		\$ 49,961.50	\$ 49,961.50	\$ -	\$ 49,961.50	\$ -
B-30006	Shenandoah Traffic Calming (Study Only)		\$ 49,878.50	\$ 49,878.50	\$ -	\$ 49,878.50	\$ -
B-30134	Bryan Park New Tennis Center		\$ 104,977.17	\$ 90,301.17	\$ 14,676.00	\$ 90,301.17	\$ -
B-30134A	Bryan Park New Tennis/Community Center		\$ 627.47	\$ 627.47	\$ -	\$ 627.47	\$ -
B-30163	Water Truck Acquisition		\$ 99,500.00	\$ 99,500.00	\$ -	\$ 99,500.00	\$ -
B-30167	Shenandoah Traffic Calming - Phase 1		\$ 1,780,500.00	\$ 103,500.00	\$ 1,677,000.00	\$ 103,500.00	\$ -
B-30168	Silver Bluff Traffic Calming - Phase 1 - D4		\$ 1,314,032.71	\$ 74,032.71	\$ 1,240,000.00	\$ 74,032.71	\$ -
B-30235	Citywide Traffic Circles D2, D3 and D4		\$ 506,100.00	\$ 30,000.00	\$ 476,100.00	\$ -	\$ 30,000.00
B-30235A	West Little Havana, Home Depot Area Traffic Circles		\$ 626,737.00	\$ 100,000.00	\$ 526,737.00	\$ 100,000.00	\$ -
B-30302	Bryan Park Interior Improvements		\$ 108,254.00	\$ 108,254.00	\$ -	\$ 108,254.00	\$ -
B-30303	Bryan Park Right-of-Way Improvements		\$ 9,246.09	\$ 9,246.09	\$ -	\$ 9,246.09	\$ -
B-30304	Shenandoah Park Improvements		\$ 244,667.00	\$ 244,667.00	\$ -	\$ -	\$ 244,667.00
B-30338	District 4 Curb Replacement		\$ 250,605.00	\$ 250,605.00	\$ -	\$ 250,604.37	\$ 0.63
B-30338A	Curb Replacement - Phase 2		\$ 97,371.00	\$ 49,395.00	\$ 47,976.00	\$ 49,395.00	\$ -
B-30690	West End Park New Community Building		\$ 1,409,070.53	\$ 1,409,070.53	\$ -	\$ -	\$ 1,409,070.53
B-39907	SW 22 Terrace Improvements - The Aston		\$ 188,623.00	\$ 188,623.00	\$ -	\$ 188,623.00	\$ -
B-40661	Citywide Curb Replacement Project		\$ 142,468.97	\$ 79,807.00	\$ 62,661.97	\$ 79,807.00	\$ -
B-40664	Citywide Sidewalk Replacement Phase 24		\$ 601,750.85	\$ 300,000.00	\$ 301,750.85	\$ -	\$ -
B-40672	Flagami Neighborhood Traffic Calming Improvements (Phase I)		\$ 949,061.00	\$ 595,666.00	\$ 353,395.00	\$ 595,666.00	\$ -
B-40698	SW 16 Terrace Road Reconstruction Project		\$ 1,302,185.16	\$ 1,061,500.00	\$ 240,685.16	\$ 1,061,500.00	\$ -
B-50699	SW 11 Street Reconstruction Project		\$ 105,364.90	\$ 105,364.90	\$ -	\$ 105,364.90	\$ -
Total - Quality of Life District 4		\$ 5,000,000	\$ 9,940,982	\$ 5,000,000	\$ 4,940,982	\$ 3,016,262	\$ 1,683,738
B-30198	Little Haiti Freedom Garden		\$ 40,361.00	\$ 3,495.00	\$ 36,866.00	\$ 3,495.00	\$ -
B-30299	Black Police Precinct/Courthouse Museum Restoration		\$ 380,946.16	\$ 380,946.16	\$ -	\$ 380,946.16	\$ -
B-30299A	Black Police Precinct/ Museum / Employee Training		\$ 31,976.77	\$ 31,976.77	\$ -	\$ 31,976.77	\$ -
B-30305	Gibson Park Improvements		\$ 250,893.12	\$ 250,893.12	\$ -	\$ 250,893.12	\$ -
B-30392	NW 58th Street and Swale Improvements		\$ 45,959.25	\$ 45,959.25	\$ -	\$ 45,959.25	\$ -
B-35887	Moore Park New Construction		\$ 25,000.00	\$ 25,000.00	\$ -	\$ 25,000.00	\$ -

HOMELAND DEFENSE NEIGHBORHOOD IMPROVEMENT BOND PROGRAM

PROJECT NO.	PROJECT NAME	ORIGINAL HD BOND AMOUNT	TOTAL PROJECT ALLOCATION	TOTAL HD ALLOCATION	OTHER SOURCES ALLOCATION	TOTAL HD INVOICED TO DATE	HD UNSPENT
B-35889	Athalie Range Park Swimming Pool Improvements		\$ 380,726.07	\$ 380,726.07	\$ -	\$ 380,726.07	\$ -
B-35889A	Athalie Range Park Pool Improvements		\$ 85,367.01	\$ 85,367.01	\$ -	\$ 85,367.01	\$ -
B-35908	Belafonte Tacolcy Center Site Improvements		\$ 34,412.50	\$ 34,412.50	\$ -	\$ 34,412.50	\$ -
B-40665	Brentwood Village Project		\$ 800,000.00	\$ 800,000.00	\$ -	\$ 100,908.35	\$ 699,091.65
B-40699	Buena Vista Heights - Ph.I		\$ 1,183,280.31	\$ 1,031,527.77	\$ 151,752.54	\$ 1,031,527.77	\$ -
B-60493	Lemon City Prk Security/B-ball Crt Lght Proj		\$ 5,846.00	\$ 5,846.00	\$ -	\$ 5,846.00	\$ -
B-78500	Buena Vista East Historic District- Streetscape Improvements PH_1		\$ 1,156,957.29	\$ 1,124,805.29	\$ 32,152.00	\$ 1,124,805.29	\$ -
B-78500A	Buena Vista East Historic District - Streetscape Improvements PH_2		\$ 2,381,584.73	\$ 403,620.73	\$ 1,977,964.00	\$ 403,620.73	\$ -
Total - Quality of Life District 5		\$ 5,000,000	\$ 6,803,310	\$ 4,604,576	\$ 2,198,735	\$ 3,905,484	\$ 699,092

Historic Preservation Initiatives

B-30121	Historic Preservation Initiatives - City Hall		\$ 1,072,999.00	\$ 494,846.00	\$ 578,153.00	\$ 100,581.36	\$ 394,264.64
B-30218	Spring Garden Point Park Privacy Wall		\$ 32,040.00	\$ 11,200.00	\$ 20,840.00	\$ 11,200.00	\$ -
B-30273	Spring Garden Point Park Seybold Canal House Restoration		\$ 32,500.00	\$ 12,500.00	\$ 20,000.00	\$ 12,500.00	\$ -
B-30299	Black Police Precinct/Courthouse Museum Restoration		\$ 1,944,985.00	\$ 1,342,040.00	\$ 602,945.00	\$ 1,342,040.00	\$ -
B-30532	Old Miami High restoration		\$ 416,156.92	\$ 60,156.92	\$ 356,000.00	\$ 60,156.92	\$ -
B-30546	Gusman Hall Improvements		\$ 2,425,000.00	\$ 825,000.00	\$ 1,600,000.00	\$ 825,000.00	\$ -
B-30655	City Hall Emergency Chattahoochee Removal		\$ 2,022.00	\$ 2,022.00	\$ -	\$ 2,006.66	\$ 15.34
B-3290A	Miami High School Bungalow Relo/Stabilization		\$ 427,439.21	\$ 251,088.00	\$ 176,351.21	\$ 251,088.00	\$ -
B-78510	Historic Preservation Initiatives - Gusman Hall		\$ 500,000.00	\$ 500,000.00	\$ -	\$ 500,000.00	\$ -
B-78512	Historic Preservation Development Initiative		\$ 20,000.00	\$ 20,000.00	\$ -	\$ 20,000.00	\$ -
B-78512A	Historic Preservation Development Initiative - Phase 2		\$ 37,500.00	\$ 37,500.00	\$ -	\$ 35,307.16	\$ 2,192.84
Total - Historic Preservation Initiatives		\$ 5,000,000	\$ 6,910,642	\$ 3,556,353	\$ 3,354,289	\$ 3,159,880	\$ 396,473

Totals	\$ 255,000,000	\$ 438,001,477	\$ 256,508,062	\$ 181,493,415	\$ 188,185,817	\$ 68,022,244
---------------	-----------------------	-----------------------	-----------------------	-----------------------	-----------------------	----------------------