



## SOUTH FLORIDA WATER MANAGEMENT DISTRICT

District Headquarters: 3301 Gun Club Road, West Palm Beach, Florida 33406 (561) 686-8800 [www.sfwmd.gov](http://www.sfwmd.gov)

Regulation  
**Application No.:** 151022-6

November 17, 2015

CITY OF MIAMI  
444 SOUTH WEST 2ND AVENUE  
MIAMI, FL 33130

Dear Permittee:

**SUBJECT: Permit No.: 13-05394-P**  
**Project :** MIAMI WOMANS CLUB SEAWALL AND BAYWALK RIPRAP  
**Location:** Miami-Dade County, S19/T53S/R42E

District staff has reviewed the information submitted October 22, 2015, for installation of a 154 LF x 2 ft wide section of riprap beneath the walkway at the site (Exhibits 1 and 2). All work will be constructed from the uplands. This letter includes authorization in the form of a letter of consent to use Sovereignty Submerged Lands for placement of riprap in accordance with the provisions of Subsection 18-21.005(1)(c)6, Florida Administrative Code.

Based on that information, District staff has determined that the proposed activities are in compliance with the original environmental resource permit and appropriate provisions of paragraph 40E-4.331(2)(b) or 62-330.315(2)(g), Florida Administrative Code. Therefore, these changes have been recorded in our files.

Your permit remains subject to the General Conditions and all other Special Conditions not modified and as originally issued.

Should you have any questions or comments regarding this authorization, please contact this office.

Sincerely,

A handwritten signature in black ink that reads "Barbara J. Conmy". The signature is written in a cursive style.

Barbara J. Conmy  
Section Leader  
Regulation Division

BC/ch

Enclosures: Exhibits 1 and 2

c: B C C Engineering  
City Of Miami  
Miami-Dade County Engineer

## **NOTICE OF RIGHTS**

As required by Sections 120.569 and 120.60(3), Fla. Stat., the following is notice of the opportunities which may be available for administrative hearing or judicial review when the substantial interests of a party are determined by an agency. Please note that this Notice of Rights is not intended to provide legal advice. Not all of the legal proceedings detailed below may be an applicable or appropriate remedy. You may wish to consult an attorney regarding your legal rights.

### **RIGHT TO REQUEST ADMINISTRATIVE HEARING**

A person whose substantial interests are or may be affected by the South Florida Water Management District's (SFWMD or District) action has the right to request an administrative hearing on that action pursuant to Sections 120.569 and 120.57, Fla. Stat. Persons seeking a hearing on a SFWMD decision which affects or may affect their substantial interests shall file a petition for hearing with the Office of the District Clerk of the SFWMD, in accordance with the filing instructions set forth herein, within 21 days of receipt of written notice of the decision, unless one of the following shorter time periods apply: (1) within 14 days of the notice of consolidated intent to grant or deny concurrently reviewed applications for environmental resource permits and use of sovereign submerged lands pursuant to Section 373.427, Fla. Stat.; or (2) within 14 days of service of an Administrative Order pursuant to Section 373.119(1), Fla. Stat. "Receipt of written notice of agency decision" means receipt of written notice through mail, electronic mail, or posting that the SFWMD has or intends to take final agency action, or publication of notice that the SFWMD has or intends to take final agency action. Any person who receives written notice of a SFWMD decision and fails to file a written request for hearing within the timeframe described above waives the right to request a hearing on that decision.

If the District takes final agency action which materially differs from the noticed intended agency decision, persons who may be substantially affected shall, unless otherwise provided by law, have an additional Rule 28-106.111, Fla. Admin. Code, point of entry.

Any person to whom an emergency order is directed pursuant to Section 373.119(2), Fla. Stat., shall comply therewith immediately, but on petition to the board shall be afforded a hearing as soon as possible.

A person may file a request for an extension of time for filing a petition. The SFWMD may, for good cause, grant the request. Requests for extension of time must be filed with the SFWMD prior to the deadline for filing a petition for hearing. Such requests for extension shall contain a certificate that the moving party has consulted with all other parties concerning the extension and that the SFWMD and any other parties agree to or oppose the extension. A timely request for an extension of time shall toll the running of the time period for filing a petition until the request is acted upon.

### **FILING INSTRUCTIONS**

A petition for administrative hearing must be filed with the Office of the District Clerk of the SFWMD. Filings with the Office of the District Clerk may be made by mail, hand-delivery, or e-mail. Filings by facsimile will not be accepted. A petition for administrative hearing or other document is deemed filed upon receipt during normal business hours by the Office of the District Clerk at SFWMD headquarters in West Palm Beach, Florida. The District's normal business hours are 8:00 a.m. – 5:00 p.m., excluding weekends and District holidays. Any document received by the Office of the District Clerk after 5:00 p.m. shall be deemed filed as of 8:00 a.m. on the next regular business day. Additional filing instructions are as follows:

- Filings by mail must be addressed to the Office of the District Clerk, P.O. Box 24680, West Palm Beach, Florida 33416.

- Filings by hand-delivery must be delivered to the Office of the District Clerk. Delivery of a petition to the SFWMD's security desk does not constitute filing. It will be necessary to request that the SFWMD's security officer contact the Office of the District Clerk. An employee of the SFWMD's Clerk's office will receive and file the petition.
- Filings by e-mail must be transmitted to the Office of the District Clerk at [clerk@sfwmd.gov](mailto:clerk@sfwmd.gov). The filing date for a document transmitted by electronic mail shall be the date the Office of the District Clerk receives the complete document. A party who files a document by e-mail shall (1) represent that the original physically signed document will be retained by that party for the duration of the proceeding and of any subsequent appeal or subsequent proceeding in that cause and that the party shall produce it upon the request of other parties; and (2) be responsible for any delay, disruption, or interruption of the electronic signals and accepts the full risk that the document may not be properly filed.

### **INITIATION OF AN ADMINISTRATIVE HEARING**

Pursuant to Sections 120.54(5)(b)4. and 120.569(2)(c), Fla. Stat., and Rules 28-106.201 and 28-106.301, Fla. Admin. Code, initiation of an administrative hearing shall be made by written petition to the SFWMD in legible form and on 8 1/2 by 11 inch white paper. All petitions shall contain:

1. Identification of the action being contested, including the permit number, application number, SFWMD file number or any other SFWMD identification number, if known.
2. The name, address, any email address, any facsimile number, and telephone number of the petitioner and petitioner's representative, if any.
3. An explanation of how the petitioner's substantial interests will be affected by the agency determination.
4. A statement of when and how the petitioner received notice of the SFWMD's decision.
5. A statement of all disputed issues of material fact. If there are none, the petition must so indicate.
6. A concise statement of the ultimate facts alleged, including the specific facts the petitioner contends warrant reversal or modification of the SFWMD's proposed action.
7. A statement of the specific rules or statutes the petitioner contends require reversal or modification of the SFWMD's proposed action.
8. If disputed issues of material fact exist, the statement must also include an explanation of how the alleged facts relate to the specific rules or statutes.
9. A statement of the relief sought by the petitioner, stating precisely the action the petitioner wishes the SFWMD to take with respect to the SFWMD's proposed action.

### **MEDIATION**

The procedures for pursuing mediation are set forth in Section 120.573, Fla. Stat., and Rules 28-106.111 and 28-106.401–405, Fla. Admin. Code. The SFWMD is not proposing mediation for this agency action under Section 120.573, Fla. Stat., at this time.

### **RIGHT TO SEEK JUDICIAL REVIEW**

Pursuant to Section 120.68, Fla. Stat., and in accordance with Florida Rule of Appellate Procedure 9.110, a party who is adversely affected by final SFWMD action may seek judicial review of the SFWMD's final decision by filing a notice of appeal with the Office of the District Clerk of the SFWMD in accordance with the filing instructions set forth herein within 30 days of rendition of the order to be reviewed, and by filing a copy of the notice with the clerk of the appropriate district court of appeal.

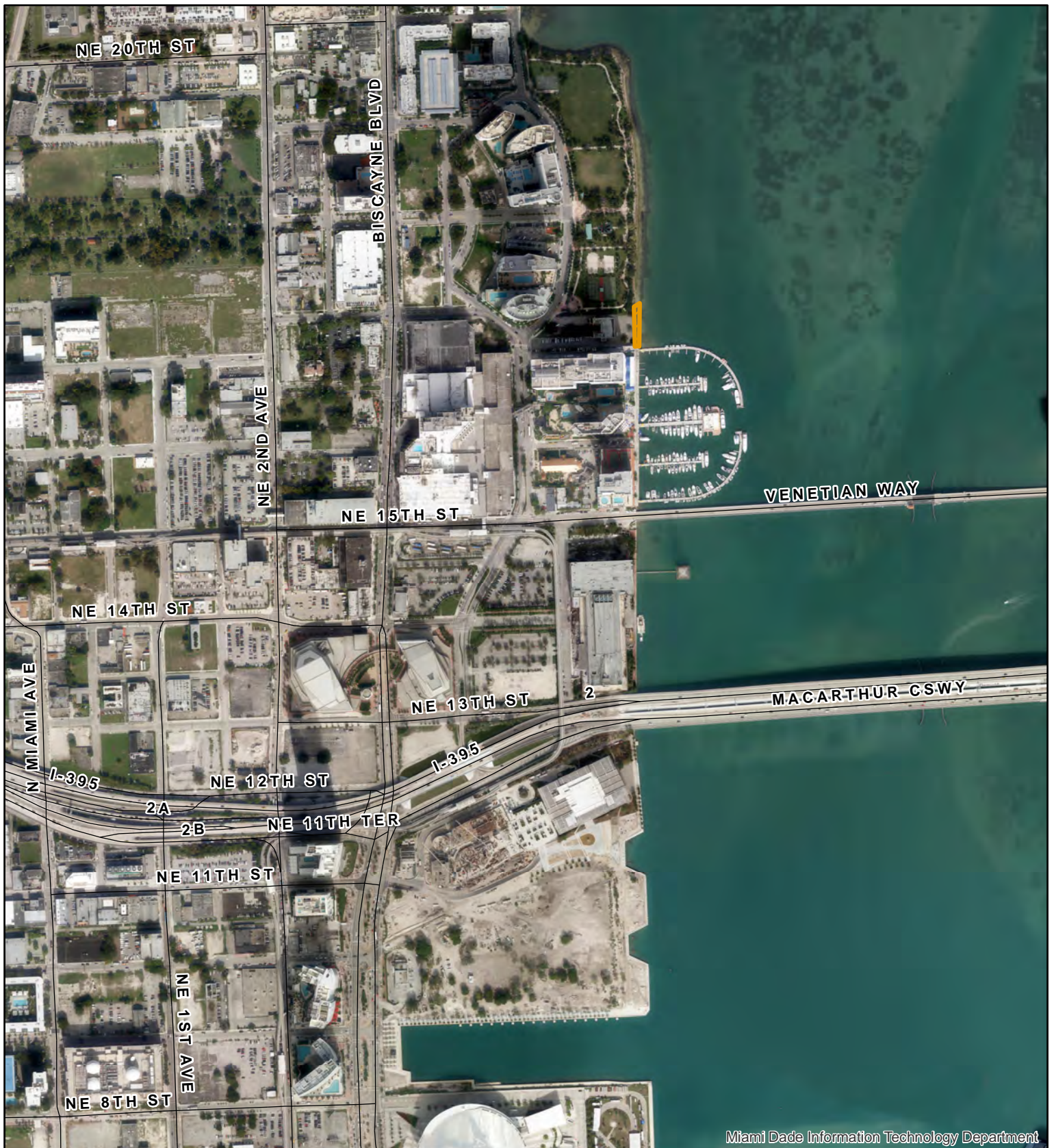

Miami Dade Information Technology Department

Exhibit No: 1

Exhibit Created On:  
2015-11-17

MIAMI-DADE COUNTY, FL

 Application

Permit No: 13-05394-P

Application Number: 151022-6



**REGULATION DIVISION**

Project Name: MIAMI WOMANS CLUB SEAWALL  
AND BAYWALK RIPRAP

N



0      550      1,100  
 Feet



South Florida Water Management District

*CITY OF MIAMI*  
*CAPITAL IMPROVEMENTS PROGRAM*

JEOVANNY RODRIGUEZ, P.E. DIRECTOR  
PROJECT No. B-30731  
MIAMI WOMAN'S CLUB  
SEAWALL & BAYWALK  
CONSTRUCTION PLANS

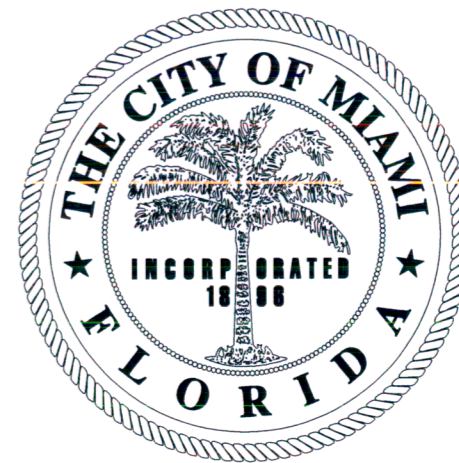

**City Officials:**

**Mayor**

Tomas P. Regalado

**Commissioner**

Wifredo (Willy) Gort

**Commissioner**

Marc Sarnoff

**Commissioner**

Frank Carollo

**Commissioner**

Francis Suarez

**Commissioner**

Keon Hardemon

**City Manager**

Daniel J. Alfonso

**City Attorney**

Victoria Mendez

**City Clerk**

Todd B. Hannon

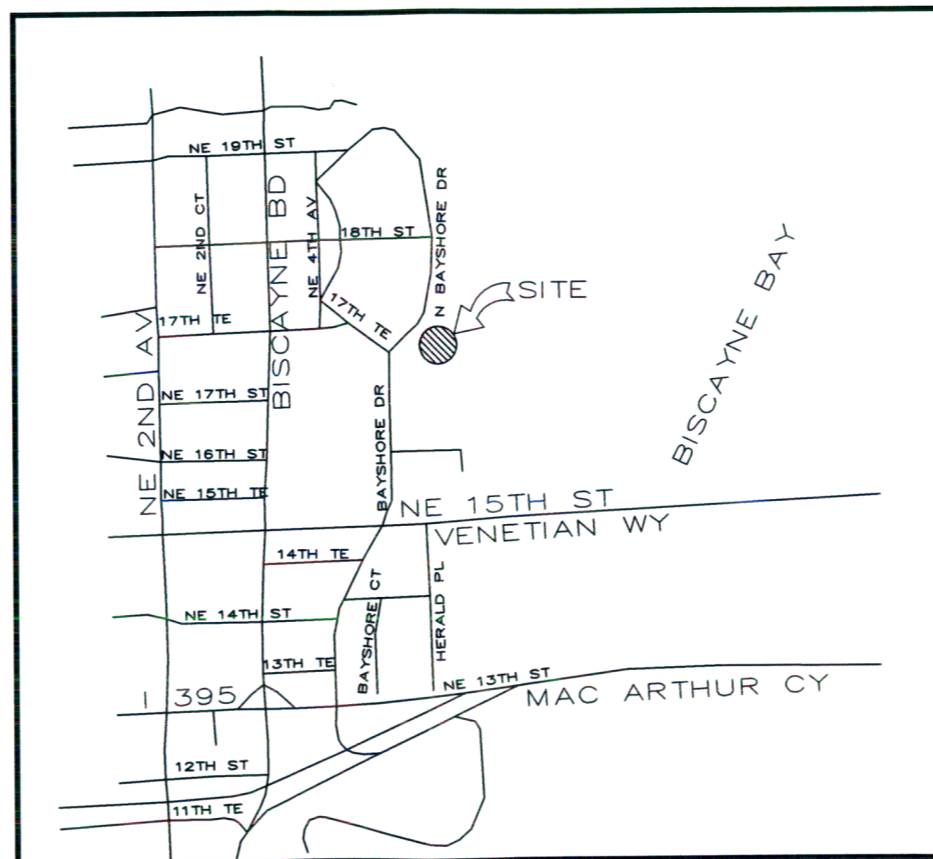
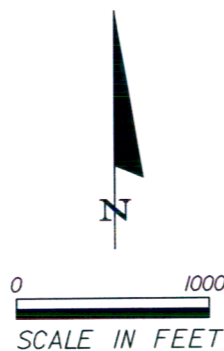

**INDEX OF SHEETS**

SHEET NO.	SHEET DESCRIPTION
1	KEY SHEET
2	SUMMARY OF QUANTITIES
3	GENERAL NOTES
4	ENGINEERING PLAN
5	AMMENITIES PLAN
6 & 7	ENGINEERING DETAILS
S-1	STRUCTURAL NOTES
S-2	KEY PLAN
S-3 to S-5	PLAN SHEETS
S-6 & S-7	SECTIONS & DETAILS
S-8	CONCRETE REPAIR DETAILS

**CIVIL SHOP DRAWINGS TO BE SUBMITTED TO:**

Christopher A. Zavatsky, P.E.  
BCC Engineering, Inc.  
7300 N Kendall Drive, Suite 400  
Miami, Florida 33156  
Phone: (305) 670-2350  
Fax: (305) 670-2351

**STRUCTURAL SHOP DRAWINGS TO BE SUBMITTED TO:**

Steve Goldstein, P.E.  
BCC Engineering, Inc.  
7300 N Kendall Drive, Suite 400  
Miami, Florida 33156  
Phone: (305) 670-2350  
Fax: (305) 670-2351

**PLANS PREPARED BY:**

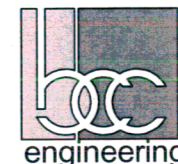

7300 N Kendall Drive, Suite 400  
Miami, Florida 33156  
Phone: (305) 670-2350  
Fax: (305) 670-2351  
Certificate of Authorization No. 7184

100% SUBMITTAL

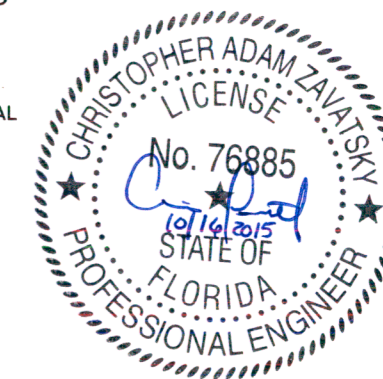

151022-6

RECEIVED

OCT 22 2015

WATER RESOURCE REGULATION

NOTE: THE SCALE OF THESE PLANS MAY HAVE CHANGED DUE TO REPRODUCTION.

ROADWAY PLANS  
ENGINEER OF RECORD: CHRISTOPHER A. ZAVATSKY, P.E.

FLORIDA LICENSE No.: 76885

GOVERNING STANDARDS AND SPECIFICATIONS:  
- FLORIDA DEPARTMENT OF TRANSPORTATION,  
DESIGN STANDARDS DATED 2010,  
AND STANDARD SPECIFICATIONS FOR ROAD AND  
BRIDGE CONSTRUCTION DATED 2010,  
AS AMENDED BY CONTRACT DOCUMENTS.  
- CITY OF MIAMI ENGINEERING STANDARDS FOR  
DESIGN AND CONSTRUCTION DATED DECEMBER 2010.

CITY OF MIAMI PROJECT MANAGER: ORLANDO MISAS

CITY OF MIAMI CONSTRUCTION MANAGER: ERIC RUSH, P.E.

SHEET NO.

1

ITEM	PAY ITEM	DESCRIPTION	UNITS	QUANTITY
1	101-1	MOBILIZATION	LS	1
2	104-10-3	SILT FENCE	LF	331
3	104-11	FLOATING TURBIDITY BARRIER	LF	175
4	104-18	INLET PROTECTION SYSTEM	EA	2
5	110-1-1	CLEARING AND GRUBBING	AC	0.084
6	120-6	EMBANKMENT (FILL TO REGRADE GREEN AREAS ALONG WALKWAY)	CY	9
7	425-2-101	HYDRO INTERNATIONAL - MODEL 4-FT DOWNSTREAM DEFENDER	EA	1
8	425-10	YARD DRAIN - NYLOPLAST (8")	EA	11
9	425-10	DRAIN BASIN - NYLOPLAST (12")	EA	1
10	430-175-112	PIPE CULV (OPT MATL)(ROUND)(8") (ALL PIPE TO BE PVC)	LF	200
11	430-175-112	PIPE CULV (OPT MATL)(ROUND)(10") (ALL PIPE TO BE HDPE)	LF	33
12	436-1-2	TRENCH DRAIN (ZURN Z-886 OR APPROVED EQUAL)	LF	8
13	455-34-2	PRESTRESSED CONCRETE PILING, 14" SQ	LF	48
14	515-2-319	PEDESTRIAN RAILING	LF	140
15	520-2-4	CONCRETE WALL	LF	144
16	550-10-929	FENCING (ALUMINUM PICKET FENCE)	LF	144
17		5' WIDE ALUMINUM SWING GATE	EA	1
18	570-1-2	PERFORMANCE TURF, SOD	SY	120
19	580-1-2	LANDSCAPE COMPLETE (CABBAGE PALM OR EQUAL)	EA	14
20		SEAWALL DEMOLITION	SF	650
21		SEAWALL REPAIR	SF	150
22		RIVER ROCK	SF	510
23		CAST-IN-PLACE CONCRETE	CY	212
24	530-2	RIP-RAP	LF	150
25		FLOOD PANEL	EA	1
26	580-332-25	TREE REMOVAL (>48")	EA	8
27	715-511-115	LIGHT POLE COMPLETE SPECIAL DESIGN (15' H), F&I	EA	5
28	721-74-1	TRASH RECEPTACLE (AS PER CITY OF MIAMI GREENWAY STANDARDS)	EA	2
29	721-75-1	BENCH (AS PER CITY OF MIAMI GREENWAY STANDARDS)	EA	4

PAY ITEM NOTES:

PAY ITEMS INCLUDES ESTIMATED QUANTITY CONTINGENT UPON FIELD CONDITIONS AND MAY BE INCREASED OR DECREASED AS DIRECTED BY THE ENGINEER.

CLEARING AND GRUBBING INCLUDES REMOVAL OF EXISTING PAVEMENT, MISCELLANEOUS CONCRETE (SEAWALL DEMOLITION), VEGETATION, TREES AND DEBRIS TO BE DISPOSED OF IN LEGAL AREAS PROVIDED BY THE CONTRACTOR. INCLUDES THE COST OF CLEANING-OUT ALL EXISTING DRAINAGE STRUCTURES WHICH ARE TO REMAIN WITHIN THE LIMITS OF CONSTRUCTION.

425-2-101 THIS PAY ITEM SHALL INCLUDE FURNISHING AND INSTALLING COMPLETE HYDRODYNAMIC DEVICE AS SPECIFIED IN THE PLANS (HYDRO INTERNATIONAL - MODEL 4-FT DIAMETER FIRST DEFENSE). INSTALLATION OF HYDRODYNAMIC DEVICES SHALL COMPLY WITH THE MANUFACTURER RECOMMENDATIONS AND SPECIFICATIONS AND WITH FDOT SPECIFICATIONS, SECTION 425 FOR INSTALLATION OF MANHOLES.

151022-6

RECEIVED

OCT 22 2015

WATER RESOURCE REGULATION



Scanned 10/22/2015 16:20 SH

REVISIONS						 Christopher A. Zavatsky, P.E. Florida License No. 76885 7300 N Kendall Drive, Suite 400 Miami, Florida 33156 Phone: (305) 670-2350 Fax: (305) 670-2351 Certificate of Authorization No. 7184	CITY OF MIAMI CAPITAL IMPROVEMENTS PROGRAM		SUMMARY OF QUANTITIES	SHEET NO.
DATE	BY	DESCRIPTION	DATE	BY	DESCRIPTION		PROJECT NAME	PROJECT ID		2
							MIAMI WOMAN'S CLUB SEAWALL & BAYWALK	B-30731		

GENERAL NOTES

1. B.M. DATA AND ELEVATION ARE CITY OF MIAMI DATUM UNLESS OTHERWISE NOTED.
2. ANY BENCH MARK MONUMENTS WITHIN THE LIMITS OF CONSTRUCTION ARE TO BE PROTECTED AND PROPERLY REFERENCED BY A REGISTERED LAND SURVEYOR IN ACCORDANCE WITH THE MINIMUM TECHNICAL STANDARDS OF THE FLORIDA BOARD OF PROFESSIONAL LAND SURVEYORS PRIOR TO BEGINNING WORK AT THE SITE. IF ANY MONUMENT IS IN DANGER OF DAMAGE, THE PROJECT ENGINEER SHALL NOTIFY THE CITY OF MIAMI SURVEYOR, DEPARTMENT OF PUBLIC WORKS, (305) 416-1200.
3. ALL PUBLIC LAND CORNERS AND MONUMENTS WITHIN THE LIMITS OF CONSTRUCTION ARE TO BE PROTECTED BY THE CONTRACTOR AS FOLLOWS: CORNERS AND CITY MONUMENTS IN CONFLICT WITH THE WORK AND IN DANGER OF BEING DAMAGED, DESTROYED, OR COVERED SHALL BE PROPERLY REFERENCED BY A REGISTERED-LAND SURVEYOR IN ACCORDANCE WITH THE MINIMUM TECHNICAL STANDARDS OF THE FLORIDA BOARD OF PROFESSIONAL LAND SURVEYORS PRIOR TO BEGINNING WORK AT THE SITE. THE CONTRACTOR SHALL RETAIN THE LAND SURVEYOR TO REFERENCE, AND RESTORE UPON COMPLETION OF THE WORK, ALL SUCH CORNERS AND MONUMENTS AND SHALL FURNISH TO CITY OF MIAMI SURVEYOR, DEPARTMENT OF PUBLIC WORKS A SIGNED AND SEALED COPY OF THE LAND SURVEYOR'S REFERENCE DRAWING.
4. ALL CONSTRUCTION SHALL BE IN STRICT ACCORDANCE WITH THE STANDARDS AND SPECIFICATIONS OF THE CITY OF MIAMI PUBLIC WORKS DEPARTMENT AND ANY OTHER STATE OR LOCAL AGENCY WITH JURISDICTION. IT IS THE INTENT OF THESE PLANS TO BE IN ACCORDANCE WITH APPLICABLE CODES AND AUTHORITIES HAVING JURISDICTION, ANY DISCREPANCIES BETWEEN THESE PLANS AND APPLICABLE CODES SHALL BE IMMEDIATELY BROUGHT TO THE ATTENTION OF THE ENGINEER OF RECORD.
5. MIAMI-DADE COUNTY WATER AND SEWER DEPARTMENT REQUIRES THAT ACCESS TO ALL WATER AND SEWER VALVES, SANITARY MANHOLES, AND OTHER CONTROL MECHANISMS BE MAINTAINED THROUGHOUT CONSTRUCTION IN THE EVENT OF AN EMERGENCY TO ENSURE THE PUBLIC HEALTH AND SAFETY. COVERING VALVE BOXES AND MANHOLES CAN BE CONSIDERED UNAUTHORIZED OBSTRUCTION OF AND TAMPERING WITH DEPARTMENT UTILITIES. CITY OF MIAMI CONTRACTOR TO COORDINATE AND WORK WITH MDWASD TO ADJUST, RELOCATE AND ISNTALL ANY MDWASD FACILITY REQUIRING WORK TO PERFORMED DURING CONSTRUCTION. FOR MANHOLE AND VALVES, CONTACT THE CONSTRUCTION MANAGEMENT SECTION (MIGUEL PICHARDO) AT (786) 268-5170. FOR THE ADJUSTMENT OF WATER METERS, CONTACT THE METER SHOP AT (786) 268-5469. FOR ANY FIRE HYDRANTS THAT ARE DAMAGED OR BUMPED DURING CONSTRUCTION, CONTACT THE MDWASD HYDRANT SHOP AT (786) 552-4926 BEFORE CASTING CONCRETE FOR THE SIDEWALK. IN THE EVENT OF A WATER OR SEWER EMERGENCY, CONTACT MIAMI DADE WATER AND SEWER DEPARTMENT EMERGENCY HOTLINE AT (786) 552-8901 THIS LINE IS OPEN 24 HOURS, 7 DAYS A WEEK.
6. CLEARING AND GRUBBING, GRADING AND OTHER INCIDENTAL WORK NECESSARY FOR HARMONIZATION OUTSIDE R/W SHALL BE INCLUDED IN RELATED BID ITEMS.
7. THE CONTRACTOR SHALL PREPARE AND SUBMIT SHOP DRAWINGS TO ENGINNER OF RECORD FOR ALL ITEMS USED IN THIS PROJECT.
8. WHEN DISSIMILAR MATERIAL CONNECTIONS ARE MADE, SUCH AS CONCRETE TO METAL, THE DISSIMILAR MATERIAL SHALL BE SEPARATED BY COATING THE CONTACT SURFACE WITH BITUMASTIC MATERIAL.
9. EXISTING DRAINAGE STRUCTURES WITHIN THE LIMITS OF CONSTRUCTION SHALL REMAIN UNLESS OTHERWISE NOTED.
10. PRIOR TO CONSTRUCTION THE CONTRACTOR WILL INSPECT ALL EXISTING STRUCTURES WHICH ARE TO REMAIN AND NOTIFY THE ENGINEER OF RECORD OF ANY OBVIOUS STRUCTURAL DEFICIENCIES
11. THERE SHALL BE NO MORE THAN THREE LATERAL DRAINAGE INSTALLATIONS WITHOUT BACKFILLING. BACKFILLING OF LATERAL DRAINAGE SHALL NOT LAG MORE THAN 72 HOURS BEHIND THE START OF EXCAVATION.
12. WHERE NEW PAVEMENT MEETS EXISTING, CONNECTION SHALL BE MADE IN A NEAT STRAIGHT LINE AND FLUSH WITH THE EXISTING PAVEMENT.
13. WHERE CONNECTIONS TO EXISTING SIDEWALKS AND DRIVEWAYS ARE NOT INDICATED ON PLANS, PROPER CONNECTIONS ARE TO BE MADE AS DIRECTED BY THE ENGINEER OF RECORD. DROP CURB AND DRIVEWAY CONNECTIONS SHALL BE PROVIDED FOR ACCESS TO ALL PRIVATE PROPERTIES ADJACENT TO THE PROJECT. PAYMENT SHALL BE INCLUDED IN THE COST OF RELATED BID ITEMS.
14. CONTRACTOR TO INSTALL PREFORMED EXPANSION JOINT WHEN PROPOSED SIDEWALK IMPROVEMENTS IS IMMEDIATELY ADJACENT TO EXISTING CONCRETE SLAB AND/OR BUILDING
15. PROPOSED ASPHALT PAVEMENT SHALL MEET APPLICABLE CITY OF MIAMI SPECIFICATIONS AND 2010 EDITION OF THE FDOT SPECIFICATIONS.
16. ALL CONCRETE SHALL DEVELOP A MINIMUM OF 3000 PSI COMPRESSIVE STRENGTH AT 28 DAYS, UNLESS OTHERWISE NOTED.
17. ALL PIPES ENTERING PROPOSED STRUCTURES SHALL BE FLUSH WITH THE INSIDE FACE OF THE WALL AND FINISHED IN A NEAT AND WORKMANLIKE MANNER.
18. THE CONTRACTOR SHALL ASSIST THE CITY WITH THE HANDLING OF PUBLIC INFORMATION MATERIALS, INCLUDING CITIZEN NOTIFICATION LETTERS AND PROJECT CONSTRUCTION SIGNS, PRIOR TO THE START OF EACH SIGNIFICANT PHASE OF CONSTRUCTION. COST OF THIS WORK SHALL BE INCLUDED IN THE MAINTENANCE OF TRAFFIC BID ITEM.
19. FOR TYPICAL TRENCH BAKCFILL FOR PROPOSED PIPES REFER TO CITY OF MIAMI STANDARD DETAIL MISC. 35-86-38.
20. CONTRACTOR SHALL AVOID DAMAGE TO EXISTING SEA WALL. ANY DAMAGE TO PRIVATE PROPERTY SHALL BE RESTORED TO ORIGINAL CONDITION OR BETTER AT NO ADDITIONAL COST TO THE OWNER.
21. ADDITIONAL WORK AS A RESULT OF THIS PROJECT IN, OVER AND UPON TIDAL WATERS OF MIAMI -DADE COUNTY REQUIRES A CLASS I PERMIT.
22. CONTRACTOR TO REFER TO STRUCTURAL DRAWINGS FOR PROJECT GEOMETRY.
23. PROPOSED STORM DRAINAGE SYSTEM SHALL NOT DISCHARGE INTO TIDAL WATERS.
24. CONTRACTOR TO COORDINATE WITH CITY OF MIAMI TO LOCATE AN APPROVED STAGING AREA.

151022-6 #

RECEIVED  
OCT 22 2015  
WATER RESOURCE REGULATION



Scanned 10/22/2015 16:20 SH

REVISIONS						 Christopher A. Zavatsky, P.E. Florida License No. 76885 7300 N Kendall Drive, Suite 400 Miami, Florida 33156 Phone: (305) 670-2350 Fax: (305) 670-2351 Certificate of Authorization No. 7184	CITY OF MIAMI CAPITAL IMPROVEMENTS PROGRAM		GENERAL NOTES	SHEET NO.  3
DATE	BY	DESCRIPTION	DATE	BY	DESCRIPTION		PROJECT NAME	PROJECT ID		
						MIAMI WOMAN'S CLUB SEAWALL & BAYWALK	B-30731			

LEGEND	
	PROPOSED SAFETY BUFFER ZONE
	PROPOSED CONCRETE BAYWALK
	PROPOSED SOD REGRADING
	PROPOSED CONCRETE HEADER
	PROPOSED NYLOPLAST DRAIN
	PROPOSED ADS DOME GRATES
	EXISTING TOPOGRAPHIC GRADE
	PROPOSED CONCRETE GRADE
	PROPOSED SOD GRADE
	PROPOSED TREE LOCATION
	FLOATING TURBIDITY BARRIER
	SILT FENCE
	PROPOSED PICKET FENCE

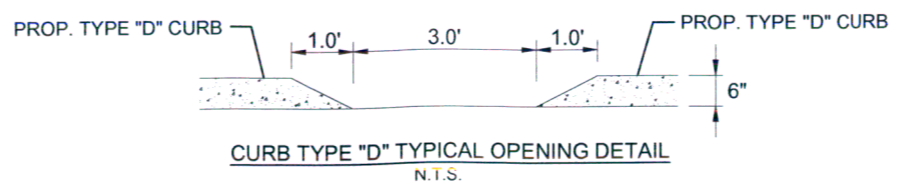

FOLIO NO.	01-3231-004-0030	01-3231-004-0021
TOTAL PROJECT AREA (5081 SF)	3516 SF	1565 SF
TOTAL PROJECT AREA ABOVE WATER	589 SF	5 SF
TOTAL PROJECT AREA LANDSIDE	2927 SF	1570 SF

CITY OF MIAMI  
 MARGARET PACE PARK  
 1775 N. BAYSHORE DRIVE  
 MIAMI, FLORIDA 33132  
 FOLIO NO. 01-3231-004-0021

TENNIS COURT

NOTE:  
 CONTRACTOR TO COORDINATE WITH CITY OF MIAMI  
 TO LOCATE AN APPROVED STAGING AREA

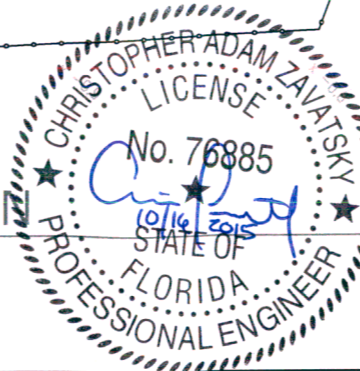
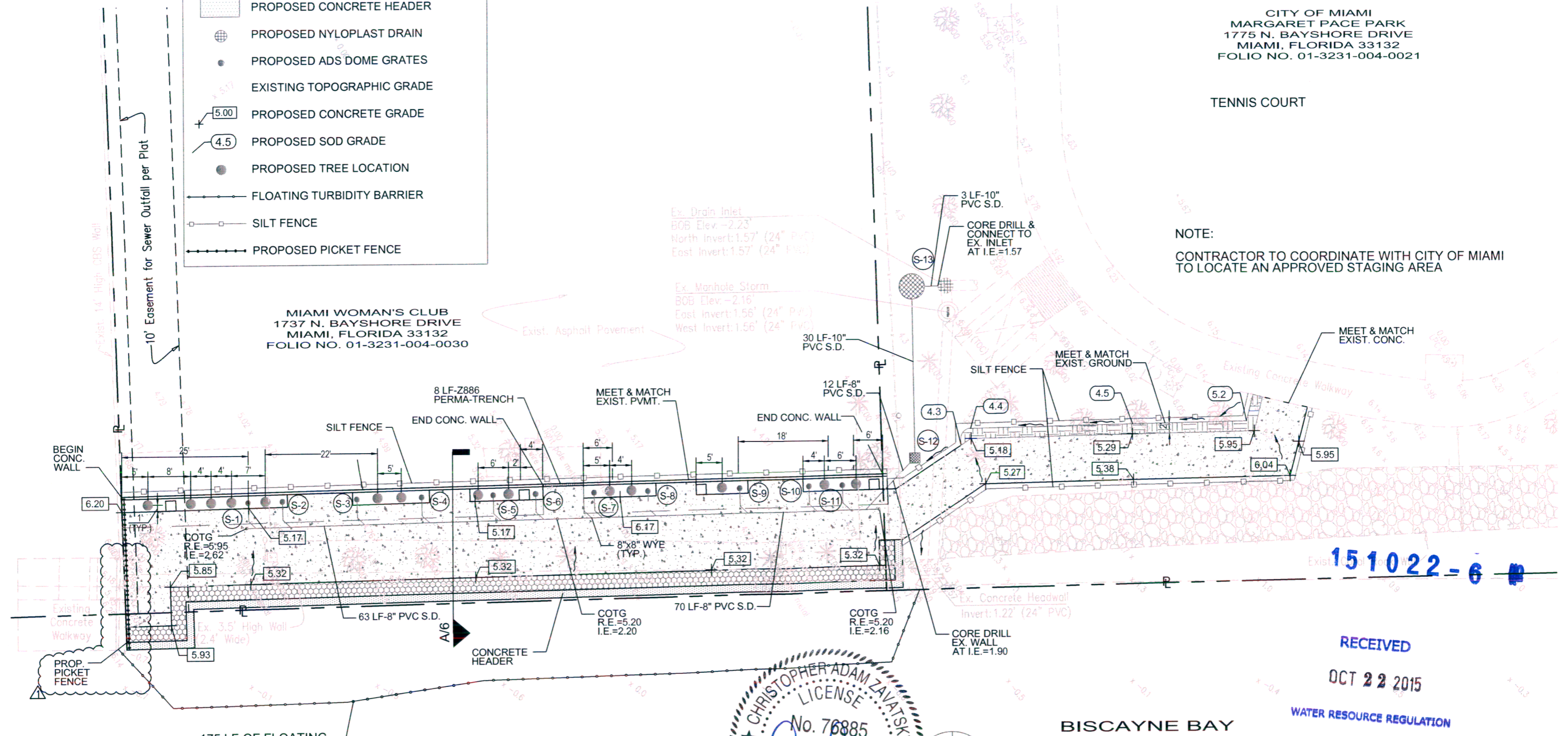

CIVIL ENGINEERING PLAN  
 SCALE: 1" = 20'

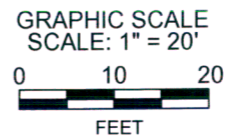

RECEIVED  
 OCT 22 2015  
 WATER RESOURCE REGULATION







REVISIONS					
DATE	BY	DESCRIPTION	DATE	BY	DESCRIPTION
8/3/2015	CAZ	△ SOUTH PROPERTY LINE REVISION			

Christopher A. Zavatsky, P.E.  
 Florida License No. 76885  
 7300 N Kendall Drive, Suite 400  
 Miami, Florida 33156  
 Phone: (305) 670-2350  
 Fax: (305) 670-2351  
 Certificate of Authorization No. 7184

CITY OF MIAMI CAPITAL IMPROVEMENTS PROGRAM	
PROJECT NAME	PROJECT ID
MIAMI WOMAN'S CLUB SEAWALL & BAYWALK	B-30731

ENGINEERING PLAN		SHEET NO.
		4



LEGEND	
	CABBAGE PALM OR EQUAL (MIN. 16' HT. OVERALL)
	BENCH (AS PER CITY OF MIAMI GREENWAY DESIGN STANDARDS)
	TRASH RECEPTACLE (AS PER CITY OF MIAMI GREENWAY DESIGN STANDARDS)
	CARMANAH EVERGEN SOLAR LUMINAIRE AND POLE

PROVIDE MASS OF GROUNDCOVER PLANTS AT THE BASE OF PALMS (MUHLY GRASS OR EQUAL)

OFFSET FROM EASEMENT LINE	
LIGHT POLES	2 LF
TREES	1.75 LF
YARD DRAINS	2 LF
BENCHES	1 LF
TRASH RECEPTACLE	1 LF

CITY OF MIAMI  
 MARGARET PACE PARK  
 1775 N. BAYSHORE DRIVE  
 MIAMI, FLORIDA 33132  
 FOLIO NO. 01-3231-004-0021

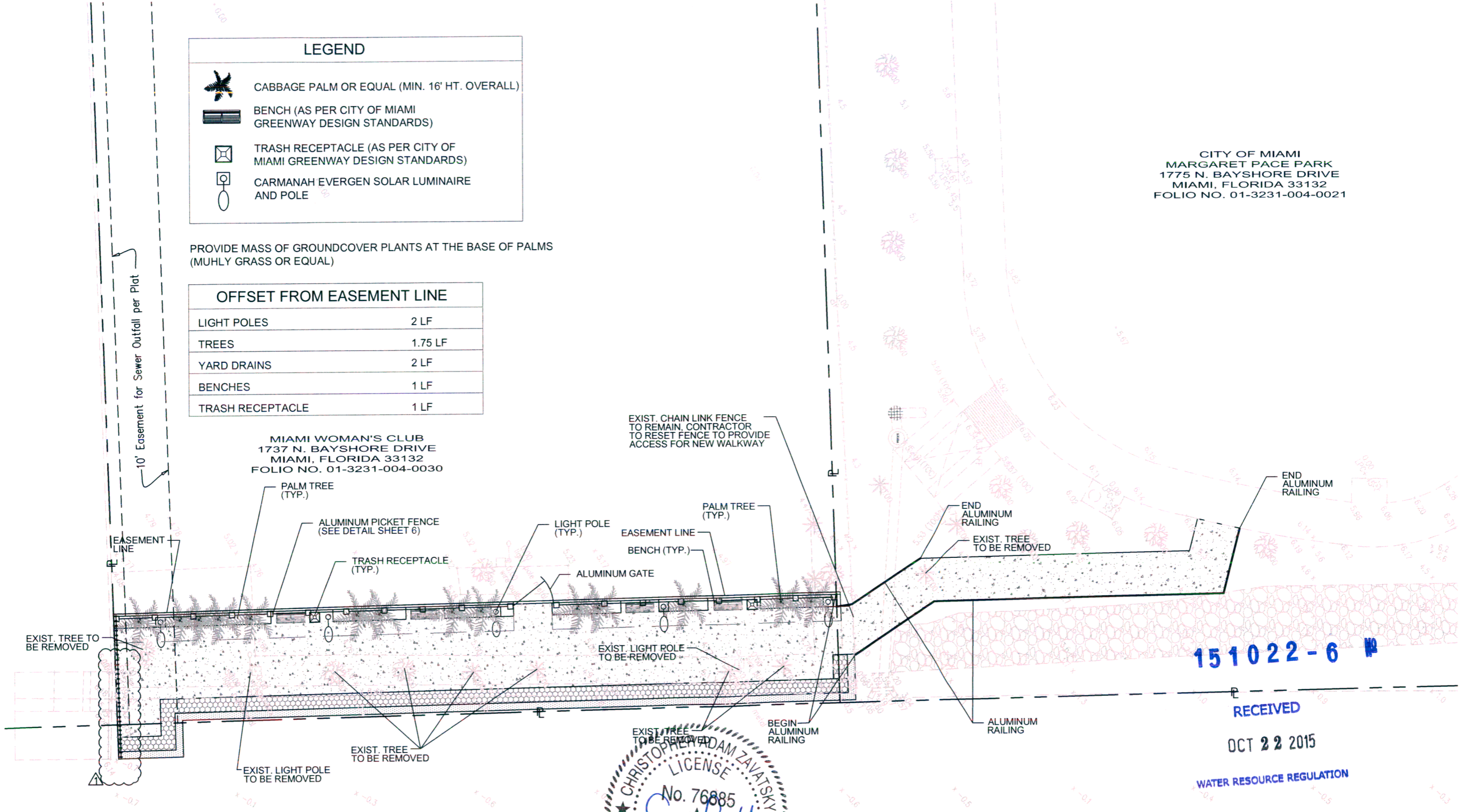

MIAMI WOMAN'S CLUB  
 1737 N. BAYSHORE DRIVE  
 MIAMI, FLORIDA 33132  
 FOLIO NO. 01-3231-004-0030

151022-6

RECEIVED

OCT 22 2015

WATER RESOURCE REGULATION

NOTE:  
 TREES TO REMAIN SHALL BE PROTECTED AGAINST DAMAGE.  
 TREES THAT ARE IN CLOSED PROXIMITY AND THE ROOT SYSTEM IS IN CONFLICT WITH THE PROPOSED CONDITION SHALL BE ROOT PRUNED 2 WEEKS PRIOR TO COMMENCING ANY OF THE PROPOSED WORK.

AMMENITIES PLAN

SCALE: 1" = 20'



BISCAYNE BAY

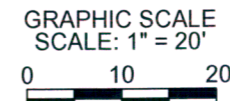

REVISIONS					
DATE	BY	DESCRIPTION	DATE	BY	DESCRIPTION
8/3/2015	CAZ	△ SOUTH PROPERTY LINE REVISION			

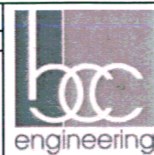

Christopher A. Zavatsky, P.E.  
 Florida License No. 76885  
 7300 N. Kendall Drive, Suite 400  
 Miami, Florida 33156  
 Phone: (305) 670-2350  
 Fax: (305) 670-2351  
 Certificate of Authorization No. 7184

CITY OF MIAMI CAPITAL IMPROVEMENTS PROGRAM	
PROJECT NAME	PROJECT ID
MIAMI WOMAN'S CLUB SEAWALL & BAYWALK	B-30731

AMMENITIES PLAN

SHEET NO.  
5

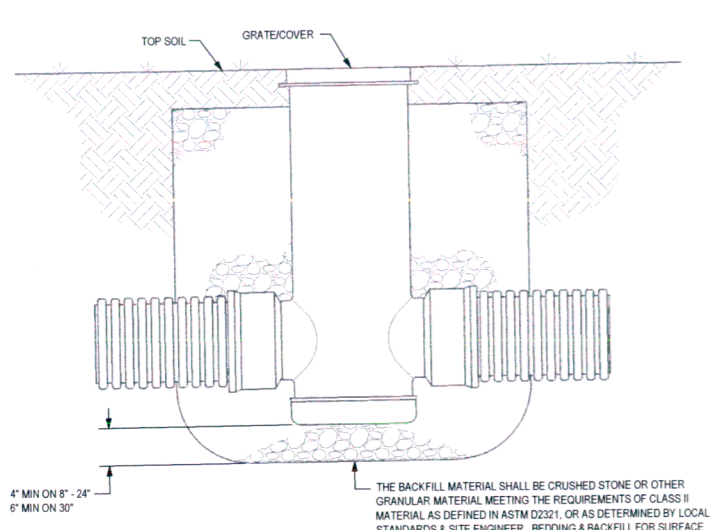

**NYLOPLAST 12" DRAIN BASIN**  
(N.T.S.)

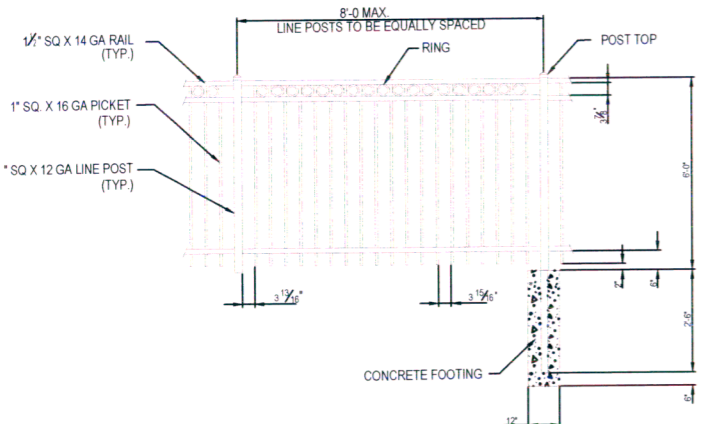

NOTES:  
ALUMINUM PICKET FENCE TO BE WITH ELECTROSTATIC PAINT FINISH BLACK

**ALUMINUM PICKET FENCE DETAIL**  
(N.T.S.)

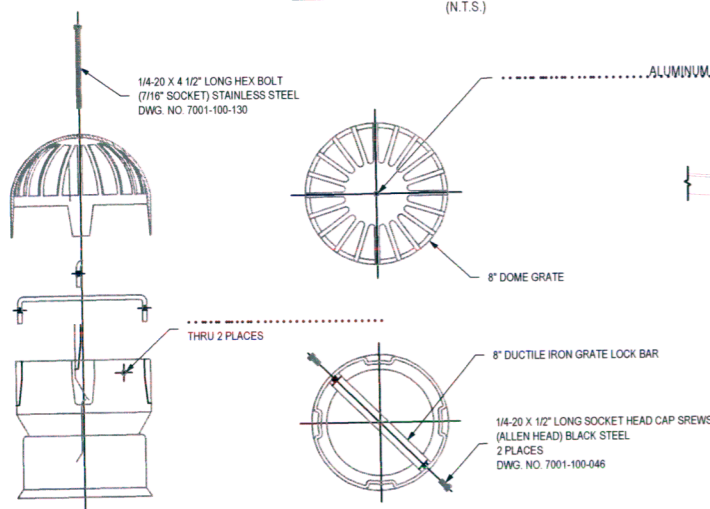

**DOME GRATE ASSEMBLY DETAIL**  
(N.T.S.)

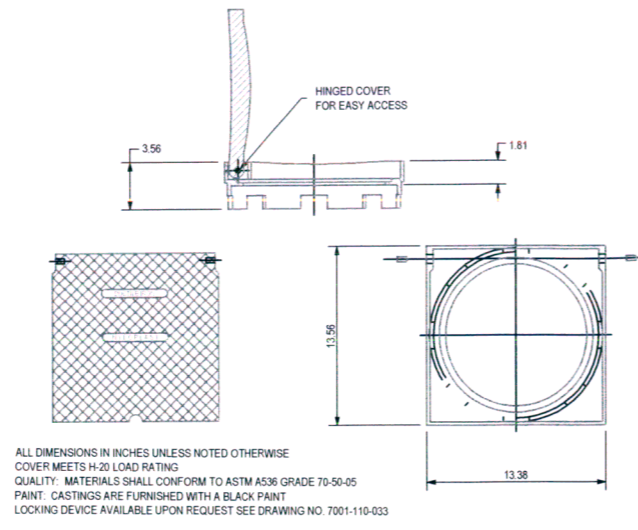

**12" SOLID COVER ASSEMBLY DETAIL**  
(N.T.S.)

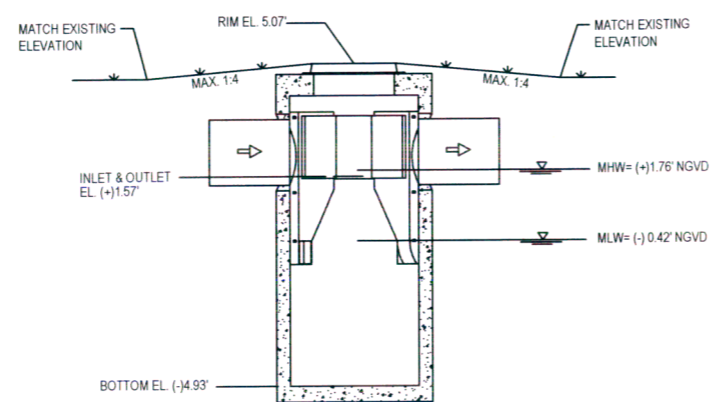

**4-FT DIAMETER FIRST DEFENSE GRADING DETAIL**  
(N.T.S.)

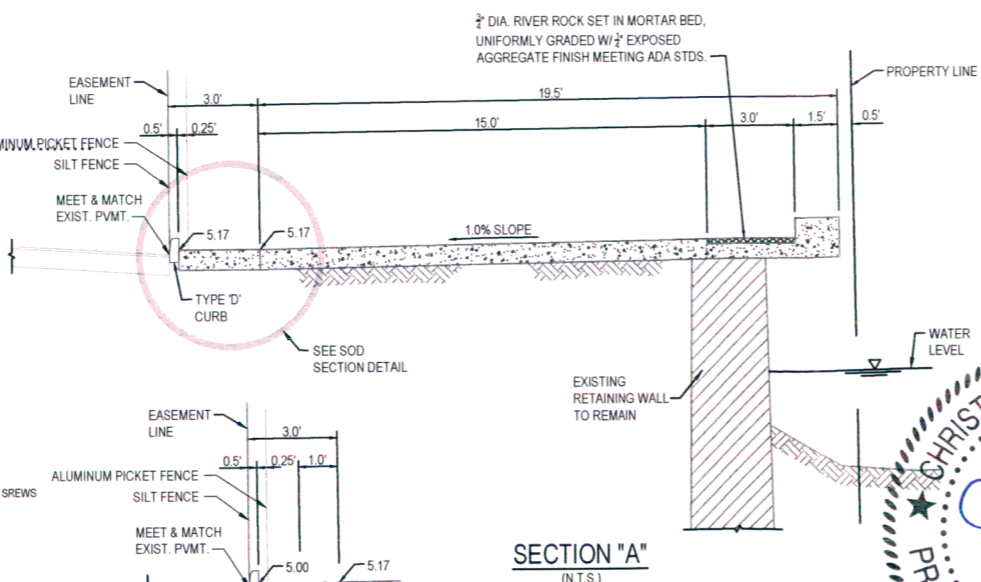

**SOD SECTION DETAIL**  
(N.T.S.)

NO.	TYPE & INSIDE DIMENSION	GRATE/RIM ELEVATION	PIPE INVERT ELEVATION				BOTTOM SLAB TOP ELEV.	PRB	REMARKS:
			N	S	E	W			
S-1	8" YARD DRAIN	4.90			2.40				NYLOPLAST DRAIN BASIN W/ DOME GRATE, HINGED DESIGN & LOCKING OPTON
S-2	8" YARD DRAIN	4.90			2.40				NYLOPLAST DRAIN BASIN W/ DOME GRATE, HINGED DESIGN & LOCKING OPTON
S-3	8" YARD DRAIN	4.90			2.40				NYLOPLAST DRAIN BASIN W/ DOME GRATE, HINGED DESIGN & LOCKING OPTON
S-4	8" YARD DRAIN	4.90			2.40				NYLOPLAST DRAIN BASIN W/ DOME GRATE, HINGED DESIGN & LOCKING OPTON
S-5	8" YARD DRAIN	4.90			2.40				NYLOPLAST DRAIN BASIN W/ DOME GRATE, HINGED DESIGN & LOCKING OPTON
S-6	8" YARD DRAIN	4.90			2.40				NYLOPLAST DRAIN BASIN W/ DOME GRATE, HINGED DESIGN & LOCKING OPTON
S-7	8" YARD DRAIN	4.90			2.40				NYLOPLAST DRAIN BASIN W/ DOME GRATE, HINGED DESIGN & LOCKING OPTON
S-8	8" YARD DRAIN	4.90			2.40				NYLOPLAST DRAIN BASIN W/ DOME GRATE, HINGED DESIGN & LOCKING OPTON
S-9	8" YARD DRAIN	4.90			2.40				NYLOPLAST DRAIN BASIN W/ DOME GRATE, HINGED DESIGN & LOCKING OPTON
S-10	8" YARD DRAIN	4.90			2.40				NYLOPLAST DRAIN BASIN W/ DOME GRATE, HINGED DESIGN & LOCKING OPTON
S-11	8" YARD DRAIN	4.90			2.40				NYLOPLAST DRAIN BASIN W/ DOME GRATE, HINGED DESIGN & LOCKING OPTON
S-12	12" DRAIN BASIN	4.00		1.85		1.85			NYLOPLAST DRAIN BASIN W/ SOLID DUCTILE IRON COVER, HINGED DESIGN & LOCKING OPTON
S-13	4 FT-DIAMETER DOWNSTREAM DEFENDER	5.07	1.57		1.57		(-) 4.93		HYDRO INTERNATIONAL - MODEL 4-FT DIAMETER DOWNSTREAM DIAMETER

**NOT FOR CONSTRUCTION - CONTACT HYDRO INTERNATIONAL FOR SITE SPECIFIC DRAWINGS**

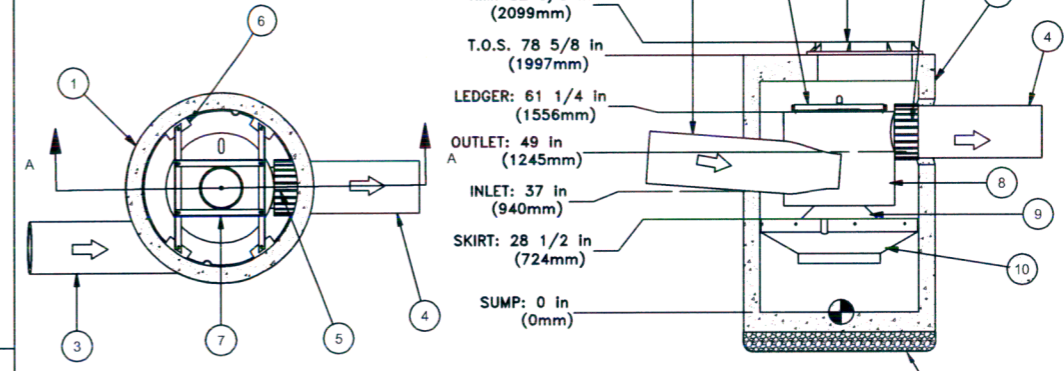

- CAPACITIES:**
- Peak treatment flow: 3.0 cfs (85 l/s)
  - Sediment storage capacity: 0.70 Cu. yd. (0.54 cu. m.)
  - Oil storage capacity: 70 Gal. (265 liters)

ITEM	DESCRIPTION	SIZE
1	PRECAST MANHOLE (BY HYDRO VIA PRECASTER)	48 in
2	FRAME AND COVER	30 in
3	INLET PIPE (BY OTHERS)	12 in
4	OUTLET PIPE (BY OTHERS)	12 in
5	PIPE COUPLING (BY OTHERS)	
6	LEDGER ANGLE	
7	SUPPORT FRAME	
8	DIP PLATE	
9	CENTER SHAFT AND CONE	
10	BENCHING SKIRT	

- ADDITIONAL DESIGN INFORMATION:**
- The outlet pipe stub (not shown) is a roto-molded product with an I.D. of 12 in. that cannot be modified. To avoid the use of a reducer or expander on the outlet a 12 in. outlet pipe should be used if possible. The orientation of the outlet pipe can be adjusted to suit site conditions.
  - Maximum pipe size is 12 in. The inlet pipe invert should be placed one inlet pipe diameter below the outlet pipe invert. The I.D. of the inlet pipe should be placed tangent to the I.D. of the manhole. The orientation of the inlet pipe can be adjusted to suit site conditions. Headloss at 3.0 cfs with a 12 in. inlet: 8 in. (203 mm). Headloss will increase with smaller inlet pipes.
  - Sediment shall be stored in a zone that is isolated from the main flow path and protected from re-entrainment by the benching skirt.
  - Dimensions are general and intended for guidance only.

Any warranty made by Hydro International only applies to those items supplied by it. Hydro International does not accept and expressly disclaims any responsibility or liability for any structures, plants or equipment (or the performance thereof) designed, built, manufactured or supplied by any third party. Hydro International has a policy of continuous product development and reserves the right to amend the specifications of any of its products or equipment at any time. Hydro International expressly disclaims any liability for the performance of its equipment (or any part thereof) used or made subject to conditions outside of the conditions set forth in Hydro International's design specifications. Hydro International owns the copyright in and to this drawing, which is supplied in confidence, and all intended recipients of the drawing, by their use thereof, agree to hold the drawing in confidence and not to use it for any purpose other than for which it was supplied and not reproduce, in whole or in part, the drawing or any of the equipment or structures depicted therein, without prior written permission of Hydro International.



151022-6

RECEIVED

OCT 22 2015

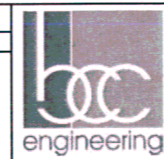

Christopher A. Zavatsky, P.E.  
Florida License No. 76885  
7300 N Kendall Drive, Suite 400  
Miami, Florida 33156  
Phone: (305) 670-2350  
Fax: (305) 670-2351  
Certificate of Authorization No. 7184

CITY OF MIAMI CAPITAL IMPROVEMENTS PROGRAM	
PROJECT NAME	PROJECT ID
MIAMI WOMAN'S CLUB SEAWALL & BAYWALK	B-30731

WATER RESOURCE REGULATION		SHEET NO. 6
ENGINEERING DETAILS		

REVISIONS					
DATE	BY	DESCRIPTION	DATE	BY	DESCRIPTION

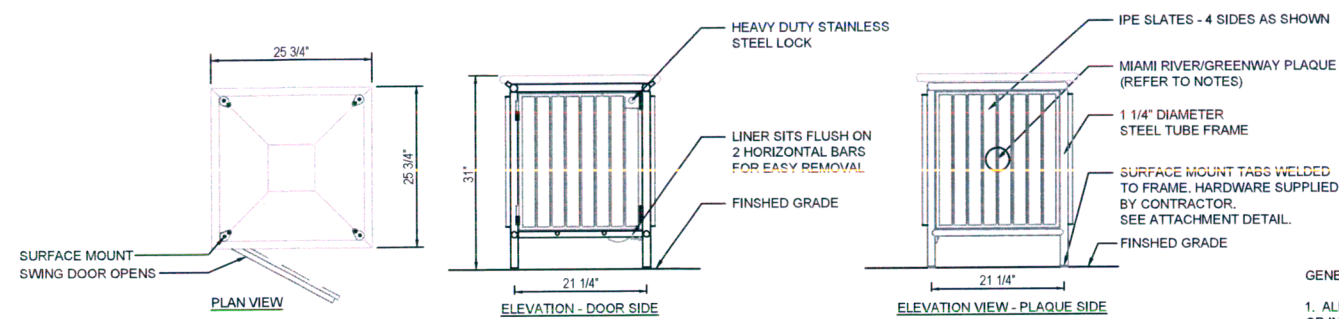

**NOTES:**  
 MANUFACTURER: LANDSCAPE FORMS, INC.  
 VENDOR: GAP ARCHITECTURAL PRODUCTS (407) 645-2854.  
 LITTER MODEL: PLAINWELL WASHINGTON SQUARE  
 LITTER RECEPTACLE WITH PLAQUE, IPE SLATS, HEAVY DUTY STAINLESS STEEL LOCK, SM TABS SURFACE MOUNT  
 STYLE: SIDE OPENING  
 MOUNTING: SURFACE-MOUNTING  
 LINER COLOR: BLACK  
 FINISH: PANGARD II® POLYESTER POWDERCOAT  
 FINISH COLOR: BLACK  
 ANCHORS: STAINLESS STEEL  
**NOTES:**  
 1. ALL HARDWARE SUPPLIED BY CONTRACTOR TO BE STAINLESS STEEL.  
 2. ANCHORS TO BE 3/8" DIA., STUD TYPE EXPANSION ANCHOR, MIN. OF 2-1/2" LONG MOUNTING HOLES ARE 7/16" DIA.  
 3. LINER TO HAVE (5) 1/2" DIAMETER HOLES TO ALLOW FOR DRAINAGE.  
 4. CONTRACTOR TO MANUFACTURE AND SUPPLY MIAMI RIVERWALK/GREENWAY PLAQUE AS PER "MIAMI RIVER REGULATORY DESIGN STANDARDS," CENTER ON PANEL OPPOSITE OF DOOR. PLAQUE INSTALLED BY LANDSCAPE FORMS, INC.

**GENERAL AMENITY FURNISHING NOTES:**  
 1. ALL SITE FURNISHINGS SHALL MEET OR EXCEED ASTM, BIFMA OR INDUSTRY STANDARDS.  
 2. SITE FURNISHING SHALL BE INSTALLED PER MANUFACTURER'S RECOMMENDATIONS.  
 3. INSTALL SITE FURNISHINGS WITH TAMPER-PROOF BOLTS OR SIMILAR AS SPECIFIED BY MANUFACTURER.  
 4. REFER TO MANUFACTURER'S PRODUCT SPECIFICATIONS FOR ALL MATERIAL SPECIFICATIONS AND INSTALLATION INSTRUCTIONS.  
 5. ALL SITE FURNISHINGS TO BE FIELD LOCATED.  
 6. MANUFACTURER NOTE: CONTRACTOR TO COORDINATE AND MANUFACTURER MIAMI RIVER/GREENWAY LOGO AS PER "MIAMI REGULATORY DESIGN STANDARDS," TO BE MOUNTED ON BENCH AND TRASH RECEPTACLE.  
 7. SUBMIT FOR REVIEW CUT SHEETS FOR ALL SITE FURNISHINGS PRIOR TO INSTALLATION. CUT SHEETS TO INCLUDE INSTALLATION METHODS OF ATTACHMENT TO CONCRETE SURFACE.

**LITTER RECEPTACLE - SURFACE MOUNTED**  
(N.T.S.)

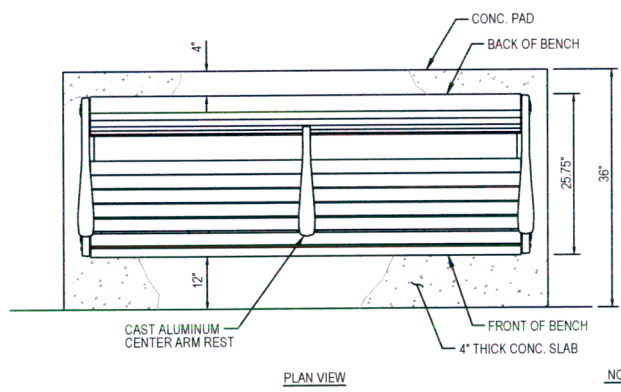

**NOTES:**  
 1. ALL HARDWARE SUPPLIED BY CONTRACTOR TO BE STAINLESS STEEL.  
 2. INSTALL PER MANUFACTURER'S SPECIFICATIONS.  
 3. SURFACE MOUNT ANCHORING TO BE USED WITH CORROSION-RESISTANT HARDWARE W/ 13/32" DIA. HOLES WITH COUNTERBORE PROVIDED FOR SOCKET HEAD CAP SCREWS.

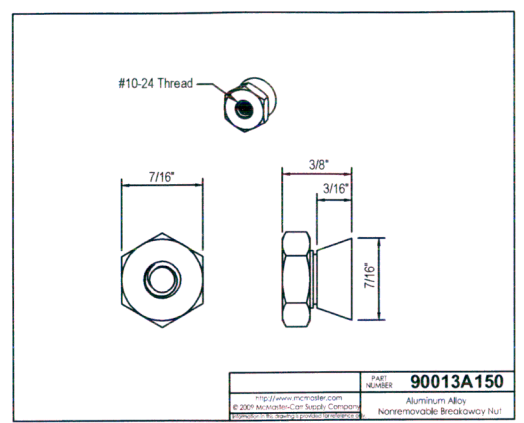

**BENCH ATTACHMENT DETAIL**  
(N.T.S.)

BENCH (PLAINWELL BENCH, 72" LENGTH, IPE WOOD SLAT PANELS WITH ALUMINUM CENTER ARM REST, COLOR: BLACK, SURFACE MOUNTED TO CONCRETE PAD)

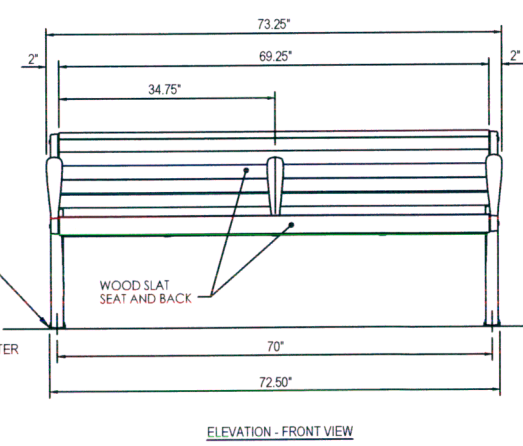

**BENCH DETAIL**  
(N.T.S.)

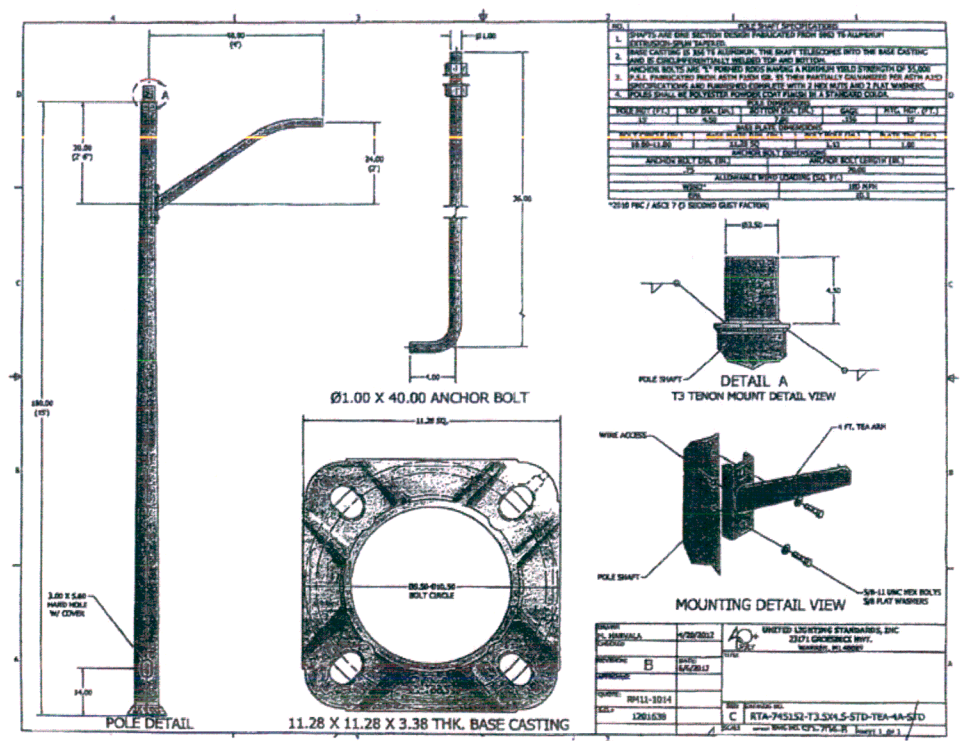
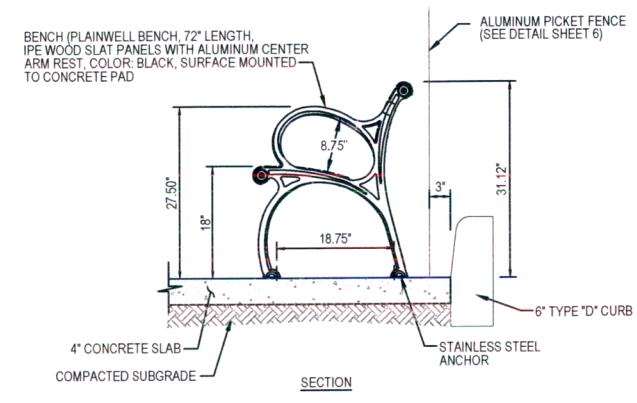

**GENERAL LIGHTING NOTES:**

- GOVERNING STANDARDS AND SPECIFICATIONS ARE: THE DESIGN STANDARDS OF 2013, THE FLORIDA DEPARTMENT OF TRANSPORTATION STANDARD SPECIFICATIONS FOR ROAD AND BRIDGE CONSTRUCTION, THE 2005 NATIONAL ELECTRICAL CODE, NATIONAL ELECTRICAL SAFETY CODE OR LATER EDITION AND LOCAL CODES WHICH EXCEEDS THESE SPECIFICATIONS.
- GROUND RODS ARE TO BE LOCATED AT EACH PULL BOX ASSOCIATED WITH A LIGHTING POLE. THE MIAMI-DADE PUBLIC WORKS STANDARDS REQUIRES A 5/8" X 20" COPPER CLAD STEEL GROUNDING ELECTRODE.
- ALL GROUNDING CONNECTIONS SHALL BE EXOTHERMICALLY WELDED AS PER FDOT SPECIFICATIONS SECTION 715-11 AND MIAMI-DADE COUNTY MAINTENANCE AGENCY NEW SPECIFICATIONS.
- LIGHT POLES SHALL BE GROUNDED WITH INSULATED GREEN THW CONDUCTORS RUNNING INSIDE THE CONDUIT.
- THE CONTRACTOR SHALL CHECK THE CONTINUITY OF GROUNDING CONDUCTOR USING MEGGER OR EQUAL LOW RESISTANCE/HIGH CAPACITY OHMMETER CALIBRATED WITHIN THE PAST 180 DAYS, A NEUTRAL/GROUND LOOP RESISTANCE OF MORE THAN 0.5 OHMS-PER THOUSAND FEET SHALL BE CONSIDERED INADEQUATE.
- PULL BOX COVER SHALL BE BOLTED TO THE PULL BOX USING A TAMPER PROOF NUT.
- THE CONTRACTOR SHALL CONSTRUCT CONCRETE SLABS AROUND ALL PULL BOXES LOCATED IN UNPAVED/GRASS AREA. SEE INDEX 17500 FOR DETAILS AND NOTES.
- CONTRACTOR IS RESPONSIBLE FOR LOCATING AND PROTECTING EXISTING UTILITIES PRIOR TO CONSTRUCTION.
- LUMINAIRE SHALL BE A 40 WATT CARMANAH EVERGEN SOLAR LED SERIES 1710 WITH A MOUNTING HEIGHT OF 15 FT.
- FOUNDATION TO BE DESIGNED BY A FLORIDA LICENSED PROFESSIONAL ENGINEER.

151022-6

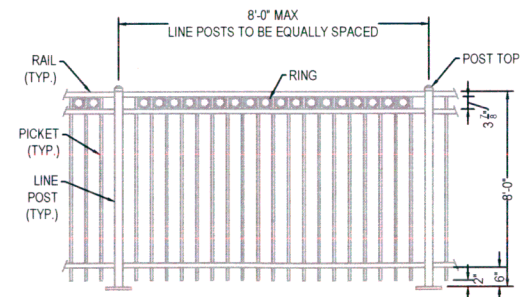

**PICKET FENCE DETAIL**  
(N.T.S.)

**NOTES:**  
 1. PICKET FENCE TO BE PAINTED GREEN.  
 2. CONTRACTOR TO RETAIN DELEGATED ENGINEER TO DESIGN FENCE ELEMENTS. SUBMIT SIGNED AND SEALED SHOP DRAWING CALCULATIONS.

RECEIVED  
OCT 22 2015

WATER RESOURCE REGULATION

Scanned 10/22/2015 16:20 SH

REVISIONS							Christopher A. Zavatsky, P.E. Florida License No. 76885 7300 N Kendall Drive, Suite 400 Miami, Florida 33156 Phone: (305) 670-2350 Fax: (305) 670-2351 Certificate of Authorization No. 7184	CITY OF MIAMI CAPITAL IMPROVEMENTS PROGRAM		SHEET NO.  7
DATE	BY	DESCRIPTION	DATE	BY	DESCRIPTION			PROJECT NAME	PROJECT ID	
							MIAMI WOMAN'S CLUB SEAWALL & BAYWALK	B-30731		

**GENERAL NOTES**

- THE GOVERNING CODE FOR THIS PROJECT IS THE FLORIDA BUILDING CODE, 2010 EDITION. THIS CODE PRESCRIBES WHICH EDITION OF EACH REFERENCED STANDARD APPLIES TO THIS PROJECT.
- TO THE BEST OF OUR KNOWLEDGE, THE STRUCTURAL DRAWINGS COMPLY WITH THE APPLICABLE REQUIREMENTS OF THE GOVERNING BUILDING CODE.
- CONSTRUCTION IS TO COMPLY WITH THE REQUIREMENTS OF THE GOVERNING BUILDING CODE AND ALL OTHER APPLICABLE FEDERAL, STATE, AND LOCAL CODES, STANDARDS, REGULATIONS AND LAWS.
- THE STRUCTURAL DOCUMENTS ARE TO BE USED IN CONJUNCTION WITH THE CIVIL DOCUMENTS. IF A CONFLICT EXISTS, THE MORE STRINGENT GOVERNS.
- DETAILS LABELED "TYPICAL" APPLY TO ALL SITUATIONS THAT ARE THE SAME OR SIMILAR TO THOSE SPECIFICALLY REFERENCED, WHETHER OR NOT THEY ARE KEYPED IN AT EACH LOCATION. QUESTIONS REGARDING THE APPLICABILITY OF TYPICAL DETAILS SHALL BE RESOLVED BY THE ENGINEER.
- CONTRACTORS WHO DISCOVER DISCREPANCIES, OMISSIONS OR VARIATIONS IN THE CONTRACT DOCUMENTS DURING BIDDING OR CONSTRUCTION SHALL IMMEDIATELY NOTIFY THE ENGINEER. THE ENGINEER WILL RESOLVE THE CONDITION AND ISSUE A WRITTEN CLARIFICATION.
- THE GENERAL CONTRACTOR SHALL COORDINATE ALL CONTRACT DOCUMENTS WITH FIELD CONDITIONS AND DIMENSIONS AND PROJECT SHOP DRAWINGS PRIOR TO CONSTRUCTION. DO NOT SCALE DRAWINGS; USE ONLY PRINTED DIMENSIONS. REPORT ANY DISCREPANCIES IN WRITING TO THE ENGINEER PRIOR TO PROCEEDING WITH WORK. DO NOT CHANGE SIZE OR LOCATION OF STRUCTURAL MEMBERS WITHOUT WRITTEN INSTRUCTIONS FROM THE STRUCTURAL ENGINEER OF RECORD.
- THE CONTRACTOR SHALL PROTECT ADJACENT PROPERTY, HIS OWN WORK AND THE PUBLIC FROM HARM. THE CONTRACTOR IS SOLELY RESPONSIBLE FOR CONSTRUCTION MEANS AND METHODS, AND JOBSITE SAFETY INCLUDING ALL OSHA REQUIREMENTS.
- THE STRUCTURE IS DESIGNED TO BE STRUCTURALLY SOUND WHEN COMPLETED. PRIOR TO COMPLETION, THE CONTRACTOR IS RESPONSIBLE FOR STABILITY AND TEMPORARY BRACING. WHEREVER THE CONTRACTOR IS UNSURE OF THESE REQUIREMENTS, THE CONTRACTOR SHALL RETAIN A FLORIDA LICENSED ENGINEER TO DESIGN AND INSPECT THE TEMPORARY BRACING AND STABILITY OF THE STRUCTURE.

**DESIGN SUPERIMPOSED LOADS:**

OCCUPANCY	LIVE LOAD	DEAD LOAD
WALKWAY	100 PSF	25 PSF (RIVER ROCK ADJACENT TO CURB)

**DESIGN WIND LOADS**

GOVERNING CODE	ASCE 7-10
BASIC WIND SPEED	V = 175 MPH
RISK CATEGORY	II
DIRECTIONALITY FACTOR	KD = 0.85
EXPOSURE - MWFRS	D
- COMPONENTS AND CLADDING	D
INTERNAL PRESSURE COEFFICIENT	GCP1 = 0.55
MEAN ROOF HEIGHT	5 FEET

**SHOP DRAWINGS AND OTHER SUBMITTALS**

- SUBMIT SPECIFIC COMPONENTS, SUCH AS BEAMS, PLANKS, ETC., IN A SINGLE PACKAGE.
- ON FIRST SUBMITTAL, CLEARLY FLAG AND CLOUD ALL DIFFERENCES FROM THE CONTRACT DOCUMENTS. ON RESUBMITTALS, FLAG AND CLOUD ALL CHANGES AND ADDITIONS TO PREVIOUS SUBMITTAL; ONLY CLOUDED ITEMS WILL BE REVIEWED.
- SUBMITTALS FOR SPECIAL STRUCTURAL, LOAD-CARRYING ITEMS THAT ARE REQUIRED BY CODES OR STANDARDS TO RESIST FORCES MUST BE PREPARED BY, OR UNDER THE DIRECT SUPERVISION OF, A DELEGATED ENGINEER. EXAMPLES INCLUDE PRECAST, PRESTRESSED CONCRETE PLANK AND PRECAST, PRESTRESSED CONCRETE PILES.
- A DELEGATED ENGINEER IS DEFINED AS A FLORIDA LICENSED ENGINEER WHO SPECIALIZES IN AND UNDERTAKES THE DESIGN OF STRUCTURAL COMPONENTS OR STRUCTURAL SYSTEMS INCLUDED IN A SPECIFIC SUBMITTAL PREPARED FOR THIS PROJECT AND IS AN EMPLOYEE OR OFFICER OF, OR CONSULTANT TO, THE CONTRACTOR OR FABRICATOR RESPONSIBLE FOR THE SUBMITTAL. THE DELEGATED ENGINEER SHALL SIGN, SEAL AND DATE THE SUBMITTAL, INCLUDING CALCULATIONS AND DRAWINGS.
- THE TRADE CONTRACTOR IS RESPONSIBLE FOR CONFIRMING AND CORRELATING DIMENSIONS AT THE JOB SITES, FOR TOLERANCES, CLEARANCES, QUANTITIES, FABRICATION PROCESSES AND TECHNIQUES OF CONSTRUCTION, COORDINATION OF THE WORK WITH OTHER TRADES AND FULL COMPLIANCE WITH THE CONTRACT DOCUMENTS.
- THE GENERAL CONTRACTOR/CONSTRUCTION MANAGER SHALL REVIEW AND APPROVE SUBMITTALS AND SHALL SIGN AND DATE EACH DRAWING PRIOR TO SUBMITTING TO THE ARCHITECT. THIS APPROVAL IS TO CONFIRM THAT THE SUBMITTAL IS COMPLETE, COMPLIES WITH THE SUBMITTAL REQUIREMENTS AND IS COORDINATED WITH FIELD DIMENSIONS, OTHER TRADES, ERECTION SEQUENCING AND CONSTRUCTABILITY.
- THE STRUCTURAL ENGINEER REVIEWS SUBMITTALS TO CONFIRM THAT THE SUBMITTAL IS IN GENERAL CONFORMANCE WITH THE DESIGN CONCEPT PRESENTED IN THE CONTRACT DOCUMENTS. QUANTITIES AND DIMENSIONS ARE NOT CHECKED. NOTATIONS ON SUBMITTALS DO NOT AUTHORIZE CHANGES TO THE CONTRACT SUM. CHECKING OF THE SUBMITTAL BY THE STRUCTURAL ENGINEER SHALL NOT RELIEVE THE CONTRACTOR OF RESPONSIBILITY FOR DEVIATIONS FROM THE CONTRACT DOCUMENTS AND FROM ERRORS OR OMISSIONS IN THE SUBMITTAL.
- IN ADDITION TO THE ABOVE, THE STRUCTURAL ENGINEER'S REVIEW OF DELEGATED ENGINEER SUBMITTALS IS LIMITED TO VERIFYING THAT THE SPECIFIED STRUCTURAL SUBMITTAL HAS BEEN FURNISHED, SIGNED AND SEALED BY THE DELEGATED ENGINEER AND THAT THE DELEGATED ENGINEER HAS UNDERSTOOD THE DESIGN INTENT AND USED THE SPECIFIED STRUCTURAL CRITERIA. NO DETAILED CHECK OF CALCULATIONS WILL BE MADE. THE DELEGATED ENGINEER IS SOLELY RESPONSIBLE FOR HIS/HER DESIGN, INCLUDING BUT NOT LIMITED TO THE ACCURACY OF HIS/HER CALCULATIONS AND COMPLIANCE WITH THE APPLICABLE CODES AND STANDARDS.

**DRIVEN PILES**

- FOUNDATION DESIGN IS BASED ON GEOTECHNICAL INVESTIGATION, DATA, AND RECOMMENDATIONS IN REPORT #21172 BY GEOSOL DATED JANUARY 11, 2012.
- STRUCTURAL DESIGN OF PILES SHALL BE BY A DELEGATED ENGINEER IN ACCORDANCE WITH FLORIDA BUILDING CODE SECTION 1825 AND ACI 543R-12.
- USE THE FOLLOWING PRECAST PRESTRESSED CONCRETE PILES:

PILE SIZE	MIN. LONGITUDINAL STRANDS	BEARING CAPACITY	LATERAL CAPACITY	MAX. CASTING LENGTH
14x14	4-7/16"	15 TONS	2 TONS	30'

USE ASTM A-416, 7 WIRE STRANDS, CONFINE WITH NO. 5 GAGE SPIRAL TIES WITH EACH END HAVING 5 TURNS AT 1" PITCH, 16 TURNS AT 3" PITCH AND THE INTERIOR TURNS AT 8" PITCH.

- CONCRETE STRENGTH SHALL BE MINIMUM 3000 PSI AT RELEASE AND MINIMUM 5000 PSI AT TIME OF DRIVING.
- INSTALL PILES IN ACCORDANCE WITH SECTION 455.B OF THE FLORIDA DEPARTMENT OF TRANSPORTATION STANDARD SPECIFICATIONS FOR ROAD AND BRIDGE CONSTRUCTION.
- PILE HAMMER AND ASSOCIATED EQUIPMENT SHALL BE LOCATED LANDWARD OF EXISTING RETAINING WALL.
- CENTER SINGLE PILES UNDER BEAMS. PLACE ALL PILES WITHIN 3" OF SPECIFIED LOCATION AND 2X OF PLUMBNESS.
- PROVIDE A SURVEY OF AS-BUILT PILE LOCATIONS. REFERENCE ALL PILES TO THEIR LOCATION SPECIFIED ON THE STRUCTURAL DRAWINGS AND FLAG ALL PILES WHICH EXCEED ALLOWABLE TOLERANCE OR ARE DAMAGED. SUBMIT SURVEY AT LEAST 48 HOURS PRIOR TO POURING AFFECTED BEAMS.

**EXCAVATION AND BACKFILL**

- THE CONTRACTOR IS SOLELY RESPONSIBLE FOR ALL EXCAVATION PROCEDURES INCLUDING LAGGING, SHORING, AND PROTECTION OF ADJACENT PROPERTY, STRUCTURES, STREETS AND UTILITIES IN ACCORDANCE WITH THE REQUIREMENTS OF THE LOCAL BUILDING DEPARTMENT AND OSHA REGULATIONS. DO NOT EXCAVATE WITHIN ONE FOOT OF THE ANGLE OF REPOSE OF ANY SOIL BEARING FOUNDATION UNLESS THE FOUNDATION IS PROPERLY PROTECTED AGAINST SETTLEMENT.
- DO NOT BACKFILL AGAINST NEW RETAINING WALLS UNTIL 7 DAYS AFTER THE WALLS ARE BRACED BY THE STRUCTURE OR ARE TEMPORARILY BRACED.

**SLABS ON GRADE**

- REFER TO GEOTECHNICAL REPORT FOR SUBGRADE PREPARATION MORE THAN 12" BELOW BOTTOM OF SLAB.
- ABOVE SUBGRADE, USE FILL CONTAINING NOT MORE THAN 10% PASSING #200 SIEVE AND MAXIMUM 1 INCH DIAMETER. COMPACT TO 95% OF MAXIMUM DRY DENSITY AS DETERMINED BY MODIFIED PROCTOR ASTM D-1557. EACH LAYER OF FILL SHALL NOT EXCEED 6" LOOSE THICKNESS. COMPACT PRIOR TO PLACEMENT OF THE NEXT LAYER.
- FILL PLACEMENT AND COMPACTION SHALL BE MONITORED AND ACCEPTED BY THE TESTING AGENCY. TAKE A MINIMUM OF TWO FIELD DENSITY TESTS (ASTM D-1556 OR D-2922). THE TESTING AGENCY SHALL RANDOMLY SELECT TEST LOCATIONS.
- DO NOT USE ANY POLYETHYLENE SHEETING BELOW EXTERIOR CONCRETE SLABS.
- USE WELDED WIRE REINFORCEMENT SUPPLIED IN FLAT SHEETS ONLY. USE CHAIRS TO SUPPORT WIRE FABRIC IN THE CENTER OF SLAB.
- PROVIDE CRACK CONTROL JOINTS AT 10 FEET MAXIMUM TO LIMIT AREAS BETWEEN JOINTS TO 100 SQ. FT. IN ALL FLOATING SLABS ON GRADE.

**REINFORCED CONCRETE**

- COMPLY WITH ACI 301-10 AND ACI 318-08.
- PROVIDE STRUCTURAL CONCRETE WITH A MINIMUM ULTIMATE COMPRESSIVE DESIGN STRENGTH IN 28 DAYS AS FOLLOWS:

ELEMENT	STRENGTH
FOOTINGS	4,000 PSI
WALLS	4,000 PSI
ELEVATED SLABS & BEAMS	5,000 PSI MAX. W/C=0.40 MAX. CHLORIDE ION CONTENT=0.15
SLABS ON GRADE	4,000 PSI

ELEVATED SLAB INCLUDES BACKUP SPAN CAST ON GRADE.

- USE NORMAL WEIGHT CONCRETE FOR ALL STRUCTURAL MEMBERS.
- PROVIDE ASTM A-615 GRADE 60 REINFORCING STEEL. REINFORCING SHALL BE ACCURATELY PLACED, RIGIDLY SUPPORTED AND FIRMLY TIED IN PLACE WITH APPROPRIATE BAR SUPPORTS AND SPACERS. LAP CONTINUOUS REINFORCING 48 BAR DIA. LAP BOTTOM STEEL OVER SUPPORTS AND TOP STEEL AT MIDSPAN (U.O.N.). HOOK DISCONTINUOUS ENDS OF ALL TOP BARS. PROVIDE COVER OVER REINFORCING AS FOLLOWS:

ELEMENT	BOTTOM	TOP	SIDES
FOOTINGS	3"	2"	3"
ELEVATED SLABS & BEAMS	1-1/2"	1-1/2"	1-1/2"
SLABS ON GRADE	3"	2"	2"
WALLS RETAINING FILL	-	-	2"

- WHERE SPECIFIED, PROVIDE PLAIN, COLD-DRAWN ELECTRICALLY-WELDED WIRE REINFORCEMENT CONFORMING TO ASTM A-185. SUPPLY IN FLAT SHEETS ONLY. LAP SPLICE ONE CROSS WIRE SPACING PLUS TWO INCHES.
- PROVIDE CONSTRUCTION JOINTS IN ACCORDANCE WITH ACI 318, SECTION 6.4. PROVIDE KEYWAYS AND ADEQUATE DOWELS. SUBMIT DRAWINGS SHOWING LOCATION OF CONSTRUCTION JOINTS AND DIRECTION OF POUR FOR REVIEW.
- PROVIDE 3/4" CHAMFER FOR ALL EXPOSED CORNERS.
- PROVIDE REINFORCING STEEL PLACER WITH A SET OF STRUCTURAL DRAWINGS FOR FIELD REFERENCE. INSPECT REINFORCING STEEL PLACING FROM STRUCTURAL DRAWINGS.
- CONCRETE COLOR SHALL BE STANDARD GRAY (NO PIGMENTS REQUIRED).
- CONCRETE SHALL BE BRUSH FINISHED IN ACCORDANCE WITH SECTION 408-B OF THE CITY OF MIAMI STANDARD SPECIFICATIONS FOR PUBLIC WORKS PROJECTS.

**DEMOLITION**

- SAWCUT PORTION OF EXISTING RETAINING WALL TO BE REMOVED. PROVIDE NETTING ON SEAWARD SIDE OF WALL TO PREVENT DEBRIS FROM FALLING INTO BAY.
- AT ALL LOCATIONS WHERE THE DEMOLITION OF A CONCRETE MEMBER LEAVES THE ENDS OF REINFORCING STEEL EXPOSED, CHIP CONCRETE AROUND THE STEEL TO A DEPTH OF 1", CUT OFF REINFORCING STEEL 3/4" BELOW THE CONCRETE SURFACE AND FILL THE CAVITY FLUSH WITH A CEMENTITIOUS REPAIR MORTAR.
- REMOVE COMPLETELY FROM THE SITE AND LEGALLY DISPOSE OF ALL DEBRIS GENERATED BY THE DEMOLITION WORK.

**EXPANSION ANCHORS**

- USE WEDGE-TYPE EXPANSION ANCHORS SUCH AS THE HILTI KWIK BOLT II, ITW RAMSET RED HEAD TRUBOLT WEDGE, POWERS RAWL POWER-STUD, SIMPSON STRONG-TIE WEDGE-ALL OR ACCEPTED EQUIVALENT. FOLLOW MANUFACTURER'S SPECIFICATIONS FOR USE AND INSTALLATION.
- CONFIRM THE ABSENCE OF REINFORCING STEEL BY DRILLING A 1/4" DIAMETER PILOT HOLE FOR EACH ANCHOR. DO NOT CUT REINFORCING STEEL WITHOUT APPROVAL OF THE STRUCTURAL ENGINEER.
- PROVIDE ANCHOR EMBEDMENT, SPACING AND EDGE DISTANCE AS SHOWN ON THE DRAWINGS.

**CHEMICAL ADHESIVE FOR ANCHORING REINFORCING BARS, THREADED BARS AND ANCHOR BOLTS**

- USE AN EPOXY, ACRYLIC OR POLYESTER RESIN ADHESIVE SYSTEM SUCH AS THE HILTI HIT HY150, ITW RAMSET/RED HEAD EPCON A7 OR C6 INJECTION SYSTEM, POWERS RAWL POWER-FAST SYSTEM, SIMPSON STRONG-TIE AT OR ET, ALLIED FASTENER ALLIED GOLD A-1000, OR ACCEPTED EQUIVALENT. FOLLOW MANUFACTURER'S SPECIFICATIONS FOR USE AND INSTALLATION.
- CONFIRM THE ABSENCE OF REINFORCING STEEL BY DRILLING A 1/4" DIAMETER PILOT HOLE FOR EACH ANCHOR. DO NOT CUT REINFORCING STEEL WITHOUT APPROVAL OF THE STRUCTURAL ENGINEER.
- REFER TO MANUFACTURER'S INSTALLATION INSTRUCTIONS FOR APPROPRIATE DRILL SIZE. THOROUGHLY CLEAN HOLE INCLUDING REMOVAL OF DUST PRIOR TO FILLING WITH EPOXY.
- PROVIDE ANCHOR EMBEDMENT, SPACING AND EDGE DISTANCE AS SHOWN ON THE DRAWINGS.
- THREADED RODS ARE A-36 GALVANIZED STEEL, U.O.N.

**FLOOD PANEL**

- CONTRACTOR SHALL FURNISH FLOOD PANEL TO BE INSTALLED AT LOCATION INDICATED ON PLAN DURING TROPICAL STORM / HURRICANE WARNINGS.
- PANEL SHALL BE DESIGNED BY A FLORIDA LICENSED DELEGATED ENGINEER RETAINED BY PANEL SUPPLIER. SUBMIT SIGNED AND SEALED SHOP DRAWINGS AND CALCULATIONS.
- PANEL DESIGN LOADS (UNFACTORED SERVICE LOADS):

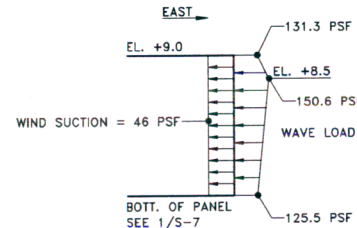

NOTE: WIND LOAD AND WAVE LOAD SHALL BE CONSIDERED SIMULTANEOUSLY AND SHALL BE COMBINED AS PER ASCE 7-10.

**RIP RAP**

- RIP RAP SHALL BE FURNISHED IN ACCORDANCE WITH FLORIDA DEPARTMENT OF TRANSPORTATION STANDARD SPECIFICATIONS FOR ROAD AND BRIDGE CONSTRUCTION (2014), SECTION 530.
  - MATERIAL SHALL BE RUBBLE (BANK AND SHORE PROTECTION) IN ACCORDANCE WITH SECTION 530-2, AND SHALL BE FREE OF PROTRUDING STEEL.
  - INSTALLATION SHALL BE IN ACCORDANCE WITH SECTION 530-3.

**STRUCTURAL SHEET LIST:**

- S-1 GENERAL NOTES
- S-2 KEY PLAN
- S-3 to S-5 PLAN SHEETS
- S-6 & S-7 SECTIONS & DETAILS
- S-8 CONCRETE REPAIR DETAILS



151022-6

RECEIVED

OCT 22 2015

WATER RESOURCE REGULATION

**REVISIONS**

DATE	BY	DESCRIPTION	DATE	BY	DESCRIPTION

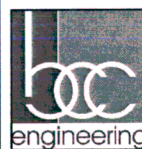

Steven Goldstein  
Florida License No. 44423  
7300 N Kendall Drive, Suite 400  
Miami, Florida 33156  
Phone: (305) 670-2380  
Fax: (305) 670-2361  
Certificate of Authorization No. 7184

**CITY OF MIAMI**  
**CAPITAL IMPROVEMENTS PROGRAM**

PROJECT NAME: MIAMI WOMAN'S CLUB SEAWALL & BAYWALK  
PROJECT ID: B-30731

**STRUCTURAL NOTES**

SHEET NO.

S-1

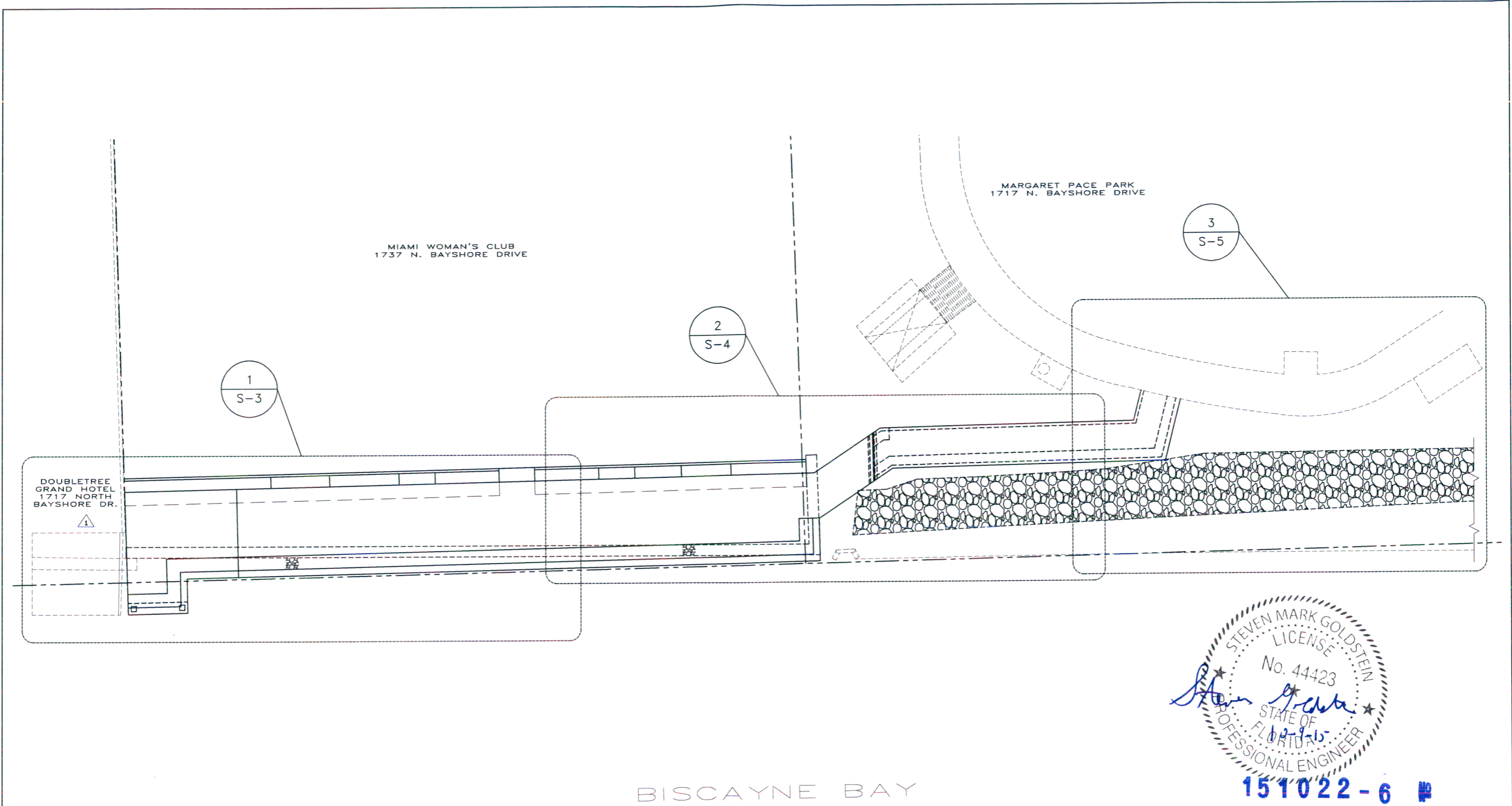

STEVEN MARK GOLDSTEIN  
LICENSE  
No. 44423  
STATE OF FLORIDA  
PROFESSIONAL ENGINEER  
151022-6

KEY PLAN  
SCALE: 1" = 20'-0"

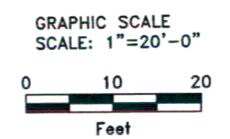

RECEIVED  
OCT 22 2015

WATER RESOURCE REGULATION

REVISIONS					
DATE	BY	DESCRIPTION	DATE	BY	DESCRIPTION
8/3/15	SG	⚠ SOUTH PROPERTY LINE REVISION			

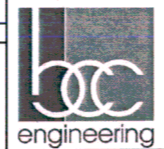

Steven Goldstein  
Florida License No. 44423  
7300 N Kendall Drive, Suite 400  
Miami, Florida 33156  
Phone: (305) 670-2390  
Fax: (305) 670-2361  
Certificate of Authorization No. 7184

CITY OF MIAMI CAPITAL IMPROVEMENTS PROGRAM	
PROJECT NAME MIAMI WOMAN'S CLUB SEAWALL & BAYWALK	PROJECT ID B-30731

<b>KEY PLAN</b>		SHEET NO. S-2
-----------------	--	------------------

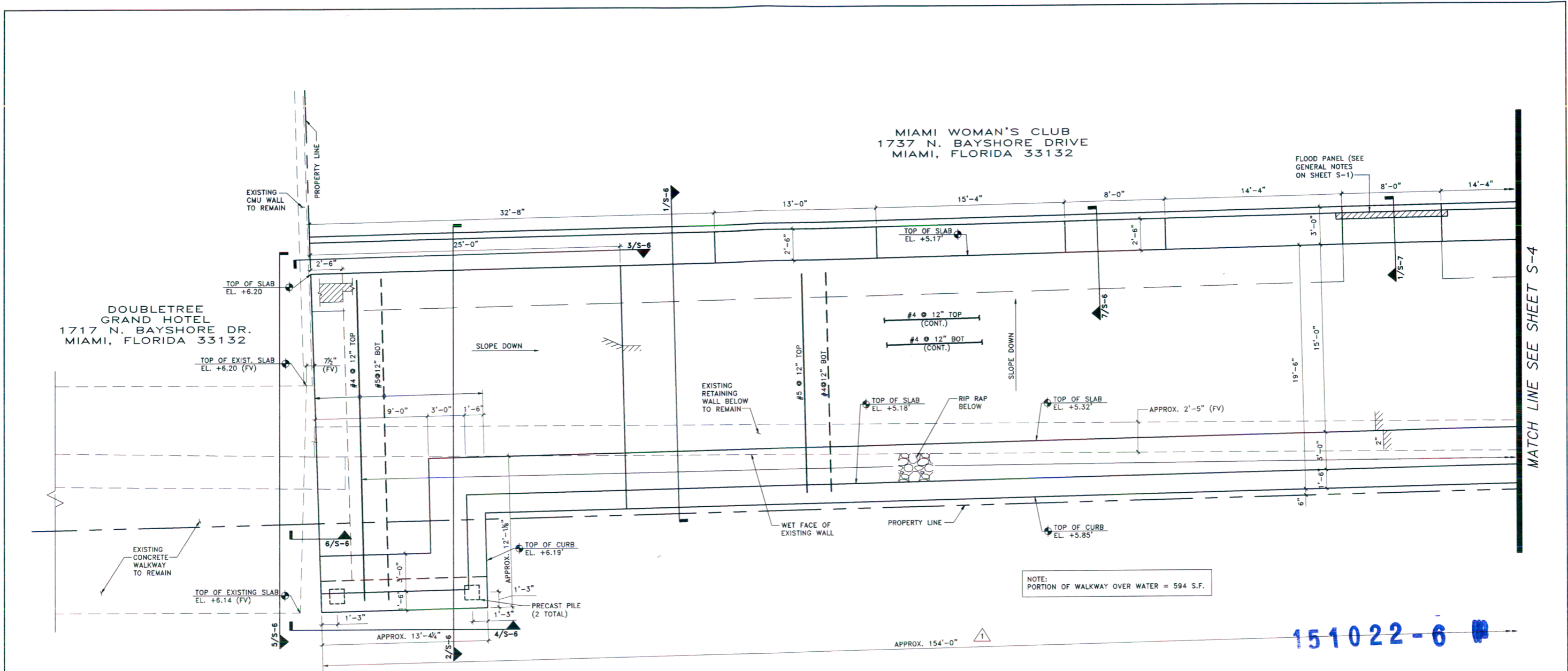

BISCAYNE BAY

**1 PLAN No. 1**  
SCALE: 1/8" = 1'-0"

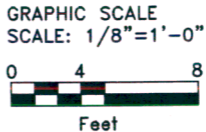

RECEIVED  
OCT 22 2015

Scanned 10/22/2015 16:20 SH

REVISIONS							Steven Goldstein Florida License No. 44423 7300 N Kendall Drive, Suite 400 Miami, Florida 33156 Phone: (305) 670-2360 Fax: (305) 670-2361 Certificate of Authorization No. 7164	CITY OF MIAMI CAPITAL IMPROVEMENTS PROGRAM		WATER RESOURCE REGULATION  <b>PLAN No. 1</b>	SHEET NO.  S-3
DATE	BY	DESCRIPTION	DATE	BY	DESCRIPTION			PROJECT NAME	PROJECT ID		
8/3/15	SG	△ SOUTH PROPERTY LINE REVISION					MIAMI WOMAN'S CLUB SEAWALL & BAYWALK	B-30731			

MARGARET PACE PARK  
1775 N. BAYSHORE DRIVE  
MIAMI, FLORIDA 33132

MIAMI WOMAN'S CLUB  
1737 N. BAYSHORE DRIVE  
MIAMI, FLORIDA 33132

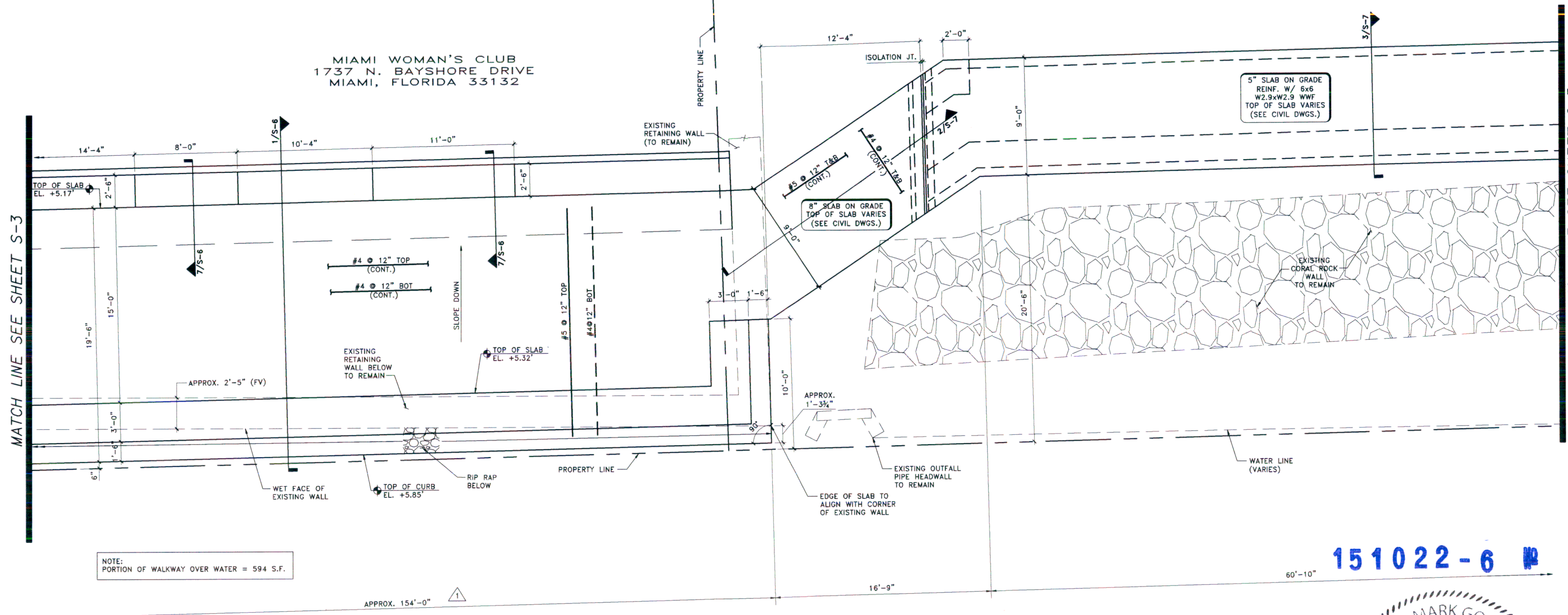

151022-6

BISCAYNE BAY

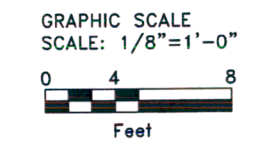

RECEIVED  
OCT 22 2015

REVISIONS					
DATE	BY	DESCRIPTION	DATE	BY	DESCRIPTION
8/3/15	SG	△ SOUTH PROPERTY LINE REVISION			

**engineering**

Steven Goldstein  
Florida License No. 44423  
7300 N Kendall Drive, Suite 400  
Miami, Florida 33158  
Phone: (305) 670-2360  
Fax: (305) 670-2361  
Certificate of Authorization No. 7164

**CITY OF MIAMI**  
**CAPITAL IMPROVEMENTS PROGRAM**

PROJECT NAME: MIAMI WOMAN'S CLUB SEAWALL & BAYWALK  
PROJECT ID: B-30731

WATER RESOURCE REGULATION

**PLAN No. 2**

SHEET NO. S-4

MARGARET PACE PARK  
1775 N. BAYSHORE DRIVE  
MIAMI, FLORIDA 33132

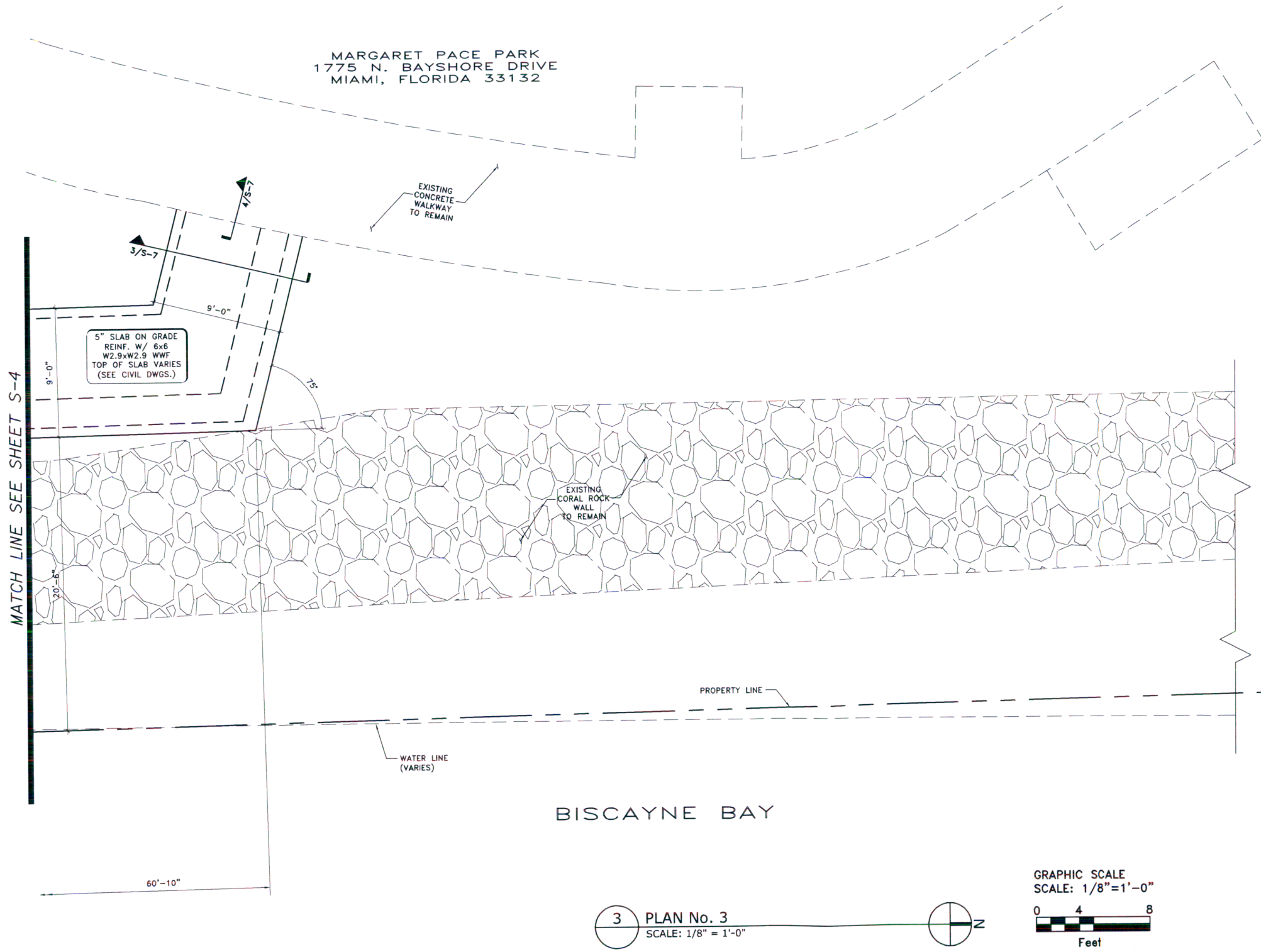

151022-6

RECEIVED

OCT 22 2015

WATER RESOURCE REGULATION

3 PLAN No. 3  
SCALE: 1/8" = 1'-0"

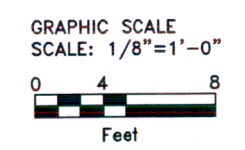

Scanned 10/22/2015 16:20 SH

REVISIONS						 Steven Goldstein Florida License No. 44423 7300 N Kendall Drive, Suite 400 Miami, Florida 33156 Phone: (305) 670-2350 Fax: (305) 670-2351 Certificate of Authorization No. 7184	CITY OF MIAMI CAPITAL IMPROVEMENTS PROGRAM		PLAN No. 3	SHEET NO.
DATE	BY	DESCRIPTION	DATE	BY	DESCRIPTION		PROJECT NAME	PROJECT ID		S-5
						MIAMI WOMAN'S CLUB SEAWALL & BAYWALK	B-30731			





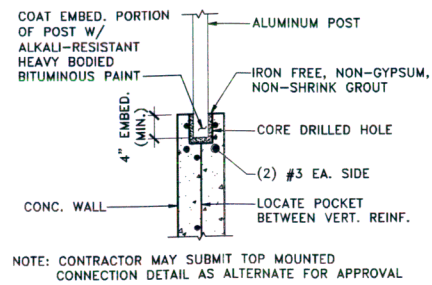

**8 TOP OF WALL DETAIL**  
SCALE: 3/4" = 1'-0"

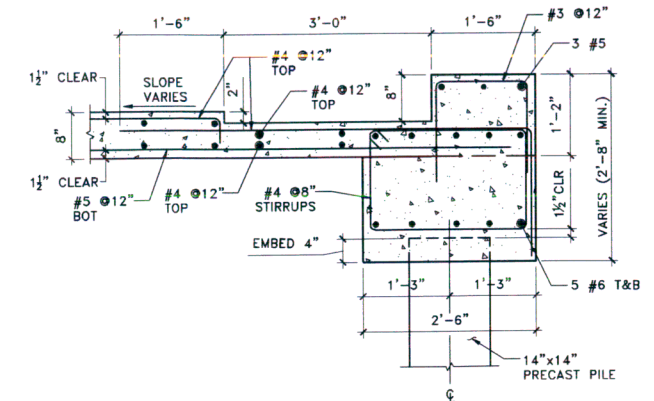

**7 BEAM DETAIL**  
SCALE: 3/4" = 1'-0"

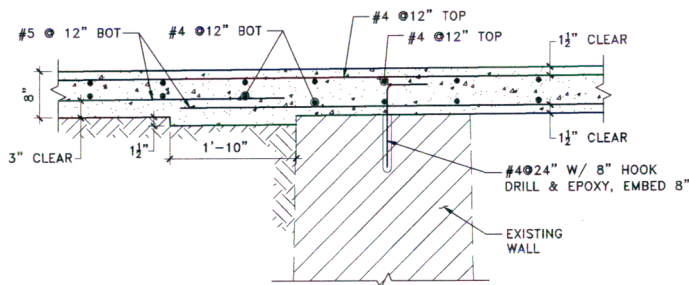

**6 WALL CONNECTION DETAIL**  
SCALE: 3/4" = 1'-0"

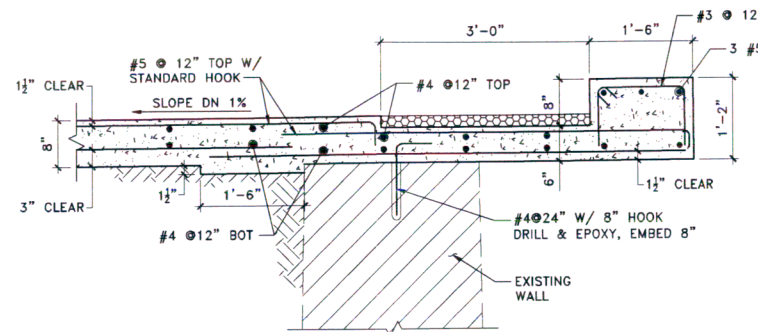

**5 SLAB EDGE DETAIL**  
SCALE: 3/4" = 1'-0"

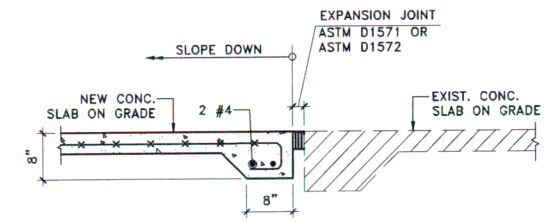

**4 SECTION AT EXISTING WALKWAY**  
SCALE: 3/4" = 1'-0"

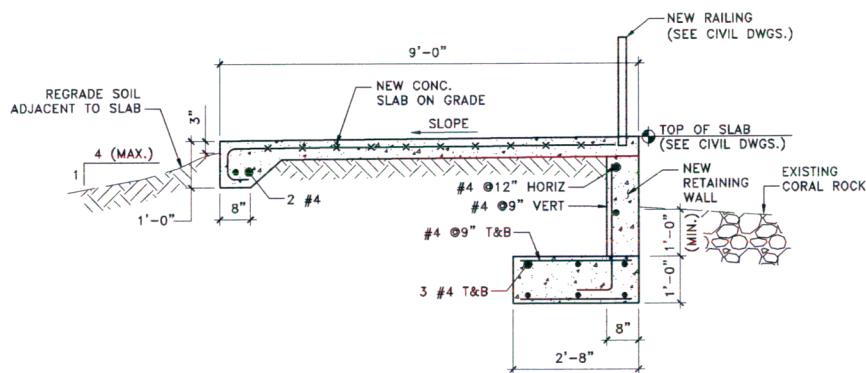

**3 SECTION THROUGH WALKWAY ON GRADE**  
SCALE: 1/2" = 1'-0"

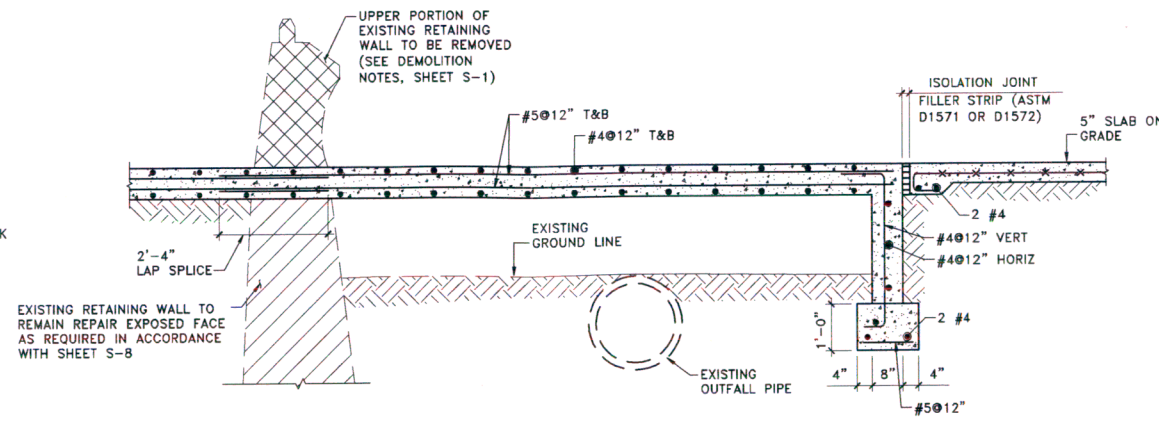

**2 SECTION AT EXPANSION JOINT AT MARGARET PACE PARK**  
SCALE: 1/2" = 1'-0"

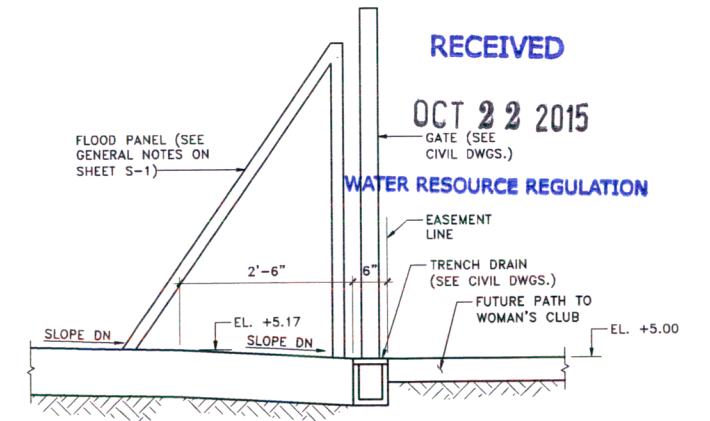

**1 SECTION AT PATH TO WOMAN'S CLUB**  
SCALE: 3/4" = 1'-0"

151022-6

RECEIVED

OCT 22 2015

WATER RESOURCE REGULATION

Scanned 10/22/2015 16:20 SH

REVISIONS							CITY OF MIAMI		SHEET NO.
DATE	BY	DESCRIPTION	DATE	BY	DESCRIPTION		CAPITAL IMPROVEMENTS PROGRAM		
						7300 N Kendall Drive, Suite 400 Miami, Florida 33108 Phone: (305) 670-2360 Fax: (305) 670-2361 Certificate of Authorization No. 7184	PROJECT NAME	PROJECT ID	<b>SECTIONS AND DETAILS</b> S-7
							MIAMI WOMAN'S CLUB SEAWALL & BAYWALK	B-30731	

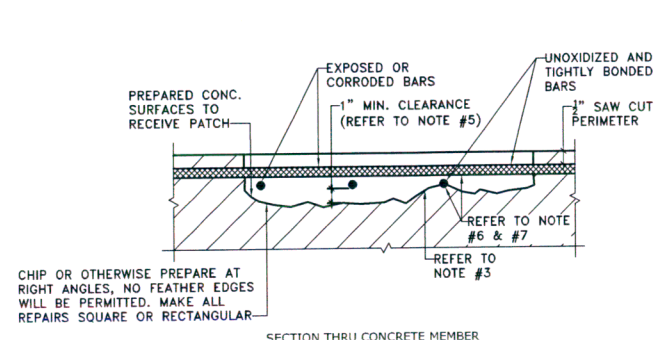

- CONCRETE DELAMINATION/SPALL REPAIR NOTES: (WITH REINFORCEMENT)**
1. PRIOR TO COMMENCING THE REPAIRS, CONTRACTOR SHALL FIELD VERIFY ALL EXISTING CONDITIONS AND NOTIFY ENGINEER OF RECORD OF ANY DISCREPANCIES.
  2. PRIOR TO COMMENCING DEMOLITION, CONTRACTOR SHALL INSTALL SHORING AS SHOWN ON PLAN.
  3. REMOVE DETERIORATED, POROUS, LOOSE, DELAMINATED CONCRETE ABOVE OXIDIZED REINFORCING STEEL. BEGIN WITH 1/2" DEEP SAWCUT OF PERIMETER. USE ONLY LIGHT ELECTRIC CHIPPING HAMMERS. NO HAMMER DRILLS. NO FEATHER EDGES PERMITTED. MAKE ALL REPAIRS SQUARE OR RECTANGULAR.
  4. ONCE INITIAL REMOVALS ARE MADE, PROCEED WITH THE UNDERCUTTING OF ALL EXPOSED OXIDIZED (CORRODED) BARS.
  5. PROVIDE MINIMUM 1" CLEARANCE BETWEEN EXPOSED REBARS AND SURROUNDING CONCRETE.
  6. CONCRETE REMOVAL SHALL EXTEND ALONG THE BARS TO A LOCATION ALONG THE BARS FREE OF BOND INHIBITING CONDITIONS, AND WHERE THE BAR IS WELL BONDED TO SOUND, NON-POROUS SURROUNDING CONCRETE.
  7. IF UNOXIDIZED REINFORCING STEEL IS EXPOSED DURING THE UNDERCUTTING PROCESS, CARE SHALL BE TAKEN NOT TO DAMAGE THE BAR'S BOND TO SURROUNDING CONCRETE. IF BOND BETWEEN BAR AND CONCRETE IS BROKEN, UNDERCUTTING OF THE BAR SHALL BE REQUIRED.
  8. CONTRACTOR SHALL NOTIFY THE ENGINEER OF RECORD IF SECTION LOSS IS GREATER THAN 20% AND/OR MORE THAN 2" UNDERCUTTING OF THE REINFORCING IS NECESSARY.
  9. SANDBLAST STEEL OR MECHANICALLY REMOVE CORROSION, SPLICE NEW BARS OF EQUAL SIZE WHERE GREATER THAN 15% TO 20% SECTION LOSS OCCURS. SPLICE LENGTH SHALL BE A MINIMUM OF 24 BAR DIAMETERS. POWER TOOL CLEANING MAY BE USED FOR SMALL SECTIONS.
  10. COAT ALL EXPOSED REINFORCING AND CONCRETE SURFACES WITH SIKA ARMATEC 110 EPOCEM (OR EQUIVALENT).
  11. PATCH WITH SIKATOP 123 PLUS (OR EQUIVALENT) WITH 3/8" AGGREGATE.

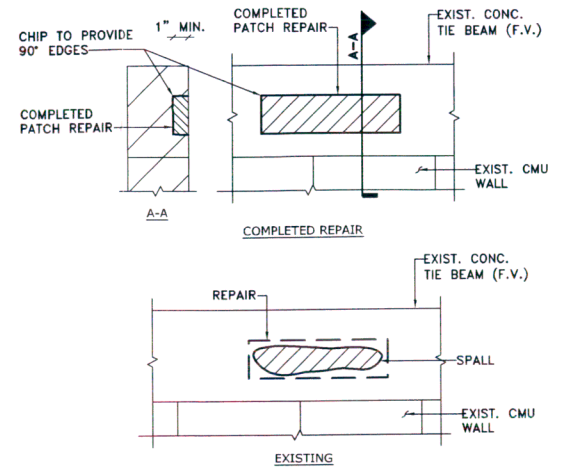

- CONCRETE DELAMINATION/SPALL REPAIR NOTES: (WITHOUT REINFORCEMENT)**
1. PRIOR TO COMMENCING THE REPAIRS, CONTRACTOR SHALL FIELD VERIFY ALL EXISTING CONDITIONS AND NOTIFY ENGINEER OF RECORD OF ANY DISCREPANCIES.
  2. CONTRACTOR SHALL NOTIFY THE ENGINEER OF RECORD IF SECTION LOSS IS GREATER THAN 20%.
  3. FOLLOW MANUFACTURER'S INSTRUCTIONS FOR SURFACE PREPARATION AND INSTALLATION.
  4. PATCH WITH SIKATOP 123 PLUS (OR EQUIVALENT).

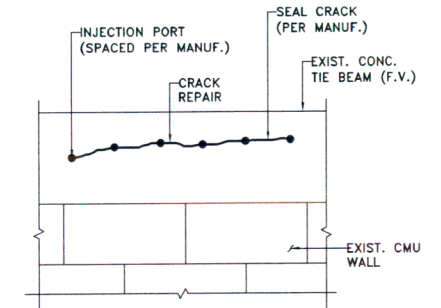

- CRACK REPAIR NOTES:**
1. PRIOR TO COMMENCING THE REPAIRS, CONTRACTOR SHALL FIELD VERIFY ALL EXISTING CONDITIONS AND NOTIFY ENGINEER OF RECORD OF ANY DISCREPANCIES.
  2. INJECT ALL CRACKS WITH SIKA CRACK FIX (OR EQUIV.) AND SIKADUR 32 HI-MOD LV (OR EQUIV.) IN ACCORDANCE WITH MANUFACTURER'S INSTRUCTIONS.

**1 CONCRETE REPAIR DETAILS**  
N.T.S.

151022-6



RECEIVED  
OCT 22 2015

Scanned 10/22/2015 16:20 SH

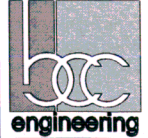
REVISIONS						 Steven Goldstein Florida License No. 44423 7300 N. Kendall Drive, Suite 400 Miami, Florida 33156 Phone: (305) 670-2350 Fax: (305) 670-2351 Certificate of Authorization No. 7184	CITY OF MIAMI CAPITAL IMPROVEMENTS PROGRAM		WATER RESOURCE REGULATION <b>CONCRETE REPAIR DETAILS</b>	SHEET NO.
DATE	BY	DESCRIPTION	DATE	BY	DESCRIPTION		PROJECT NAME	PROJECT ID		S-8
						MIAMI WOMAN'S CLUB SEAWALL & BAYWALK	B-30731			