



Wayfinding & Signage System Program

Downtown Miami, FL



Downtown Miami District ID Program

Sign No.
606



Downtown
Miami District
ID Program



DESTINATIONS

DOWNTOWN DISTRICTS

- Arts & Entertainment
- Central Business District
- Brickell

SUBDISTRICTS

- Flagler St Shopping
- Brickell Village

Transportation

- State/US Road

Wayfinding & Signage System Program

Downtown Miami, Florida

SIGN NO. 606

Location Aerial View:

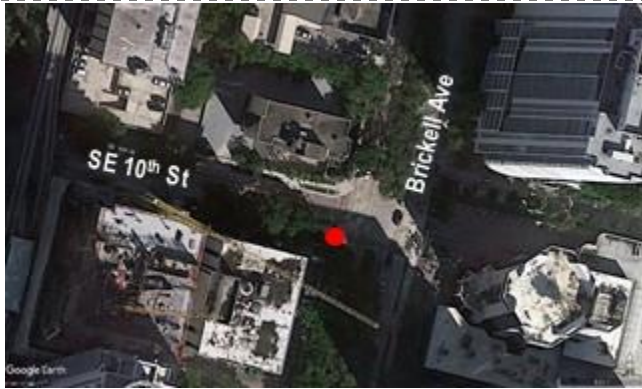

Location Photo:



Sign Type: DistID.3

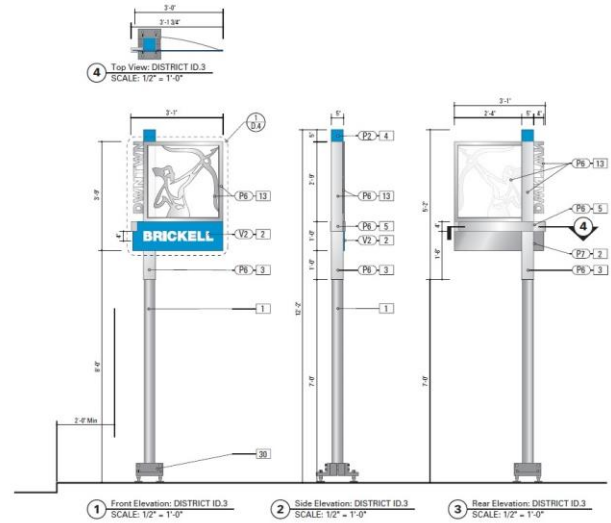

Sign Message:

Face A	Brickell District
Face B	None

Ground Condition: Concrete

Foundation Type: 2' X 3' 10" Square

Reference Intersection: SE 10th St @ Brickell Ave

Detailed Location: Replace existing district sign

Orientation: EB

Right-of-Way Summary	Utilities Summary
City of Miami	Traffic Signal TV Cable Water Main

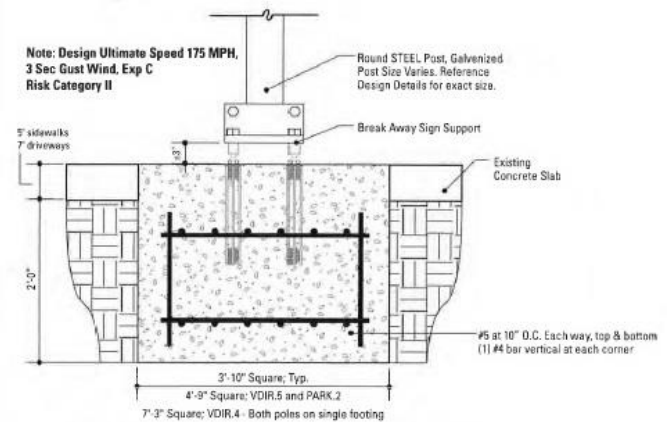

SPECIFIC PURPOSE SURVEY PROPOSED POLE 606

SURVEYOR'S REPORT :

- THE SPECIFIC PURPOSE OF THIS SURVEY IS TO SHOW THE LOCATION OF THE PROPOSED POLE IN RELATION TO THE MONUMENT LINES AND RIGHT-OF-WAY LINES.
- THIS IS NOT A BOUNDARY SURVEY
- THE LOCATION OF THE PROPOSED POLE SHOWN HEREON WAS PROVIDED BY THE CLIENT.
- THERE ARE EXISTING IMPROVEMENTS LYING WITHIN THE LIMITS OF THE SKETCH, WHICH ARE NOT SHOWN ON THIS SURVEY.
- REVIEW OF TITLE SEARCH WAS NOT PART OF THE SCOPE OF SERVICES.
- RIGHT-OF-WAY LINES AND MAPPED (ZONED) STREET LINES ARE AS PER CITY OF MIAMI ATLAS SHEET AND MIAMI-DADE COUNTY PLATS OF RECORD.
- POLE 606 LIES WITHIN THE JURISDICTION OF CITY OF MIAMI.
- INFORMATION REGARDING STREET JURISDICTION WAS TAKEN FROM MAP ENTITLED : DOWNTOWN MIAMI STREETS BY JURISDICTION PREPARED BY CITY OF MIAMI DATED SEPTEMBER 1, 2015 AND FURNISHED BY THE CLIENT.

SURVEYOR'S CERTIFICATION :

I HEREBY CERTIFY THAT THIS SPECIFIC PURPOSE SURVEY WAS PREPARED UNDER MY DIRECT SUPERVISION AND THAT IT IS TRUE AND CORRECT TO THE BEST OF MY KNOWLEDGE AND BELIEF AND I FURTHER CERTIFY THAT SAID SURVEY IS IN COMPLIANCE WITH THE STANDARDS OF PRACTICE AS SET FORTH BY THE FLORIDA BOARD OF LAND SURVEYORS AND MAPPERS IN CHAPTER 5J-17 FLORIDA ADMINISTRATIVE CODE PURSUANT TO SECTION 472.027 OF THE FLORIDA STATUTES.

 MANUEL G. VERA JR.
 PROFESSIONAL SURVEYOR AND MAPPER No. 5291
 STATE OF FLORIDA
 NOTICE: NOT VALID WITHOUT THE SIGNATURE AND ORIGINAL RAISED SEAL OF THE FLORIDA LICENSED SURVEYOR AND MAPPER.
 EACH SHEET AS INCORPORATED HEREIN SHALL NOT BE CONSIDERED FULL, VALID AND COMPLETE UNLESS ATTACHED TO THE OTHERS.

FOR SKETCH SEE SHEET 2

MANUEL G.VERA AND ASSOCIATES, INC.
 ENGINEERS-SURVEYORS & MAPPERS
 13960 S.W. 47th ST. MIAMI, FLORIDA 33175 L.B. No.2439
 PHONE: (305) 221-6210 e-mail: mverajr@mgvera.com

PROJECT NUMBER: 16-574		
TYPE OF PROJECT: SPECIFIC PURPOSE SURVEY		
PROJECT NAME: POLE LOCATION		
DATE: 06-27-2016	SCALE	SHEET
DRAWN BY: JCF	N.A.	1 OF 2

NOT A BOUNDARY SURVEY

SPECIFIC PURPOSE SURVEY PROPOSED POLE 606

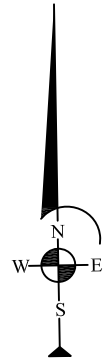

LEGEND:

- EXISTING RIGHT OF WAY LINE
- EXISTING LIMITED ACCESS RIGHT OF WAY LINE
- - - MAPPED (ZONED) STREET LINE
- ⊕ CENTER LINE
- M MONUMENT LINE

MANUEL G.VERA AND ASSOCIATES, INC.
 ENGINEERS-SURVEYORS & MAPPERS
 13960 S.W. 47th ST. MIAMI, FLORIDA 33175 L.B. No.2439
 PHONE: (305) 221-6210 e-mail: mverajr@mgvera.com

NOT A BOUNDARY SURVEY

PROJECT NUMBER: 16-574		
TYPE OF PROJECT: SPECIFIC PURPOSE SURVEY		
PROJECT NAME: POLE LOCATION		
DATE: 06-27-2016	SCALE	SHEET
DRAWN BY: JCF	1"=30'	2 OF 2



LOCATION DESCRIPTION:

Brickell Ave. S/O SE 10th St.

FOR EXACT SIGN POST LOCATION
PLEASE REFER TO ATTACHED
SPECIFIC PURPOSE SURVEY SKETCH

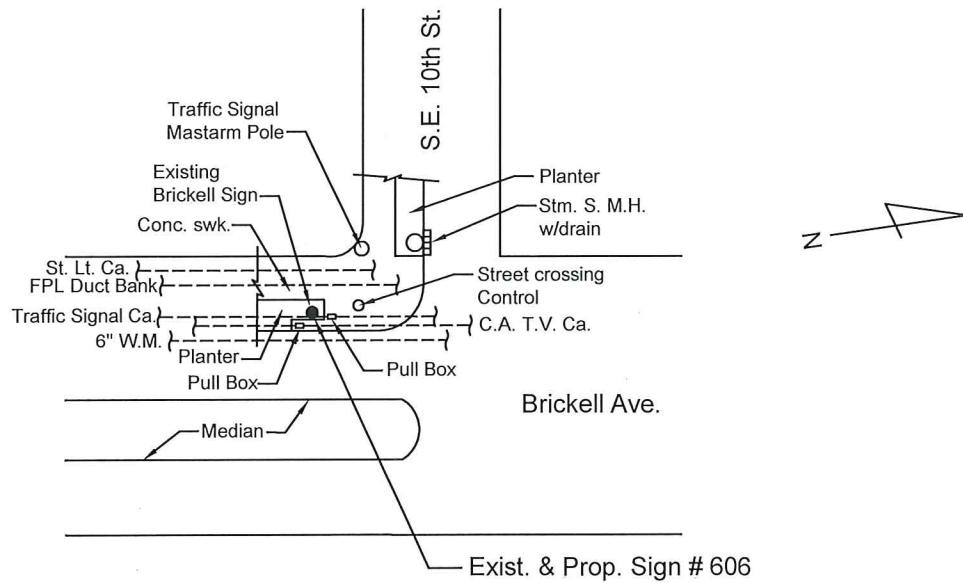

PLAN
NTS

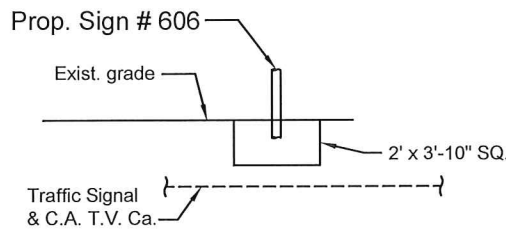

PROFILE
NTS

COMMENTS: Best Footer for Prop. Sign # 606 is: 2' x 3'-10" SQ.

MIAMI DDA - WAYFINDING AND SIGNAGE SYSTEM PROGRAM

DISCLAIMER:
This sketch has been prepared
for utility coordination purposes only.
This sketch is Not for Construction.

Utility coordination done by:
JRA Inc.
engineers-planners
10661 N Kendall Dr., Ste. 206B
Miami, FL 33176-1550
Phone 305-270-7800
CA 7613

CITY OF MIAMI

SIGN No. 606

Type Dist - ID.3

DATE: 03-28-2017

Sign No.
607



Downtown
Miami District
ID Program



Wayfinding & Signage System Program

Downtown Miami, Florida

SIGN NO. 607

Location Aerial View:



Location Photo:

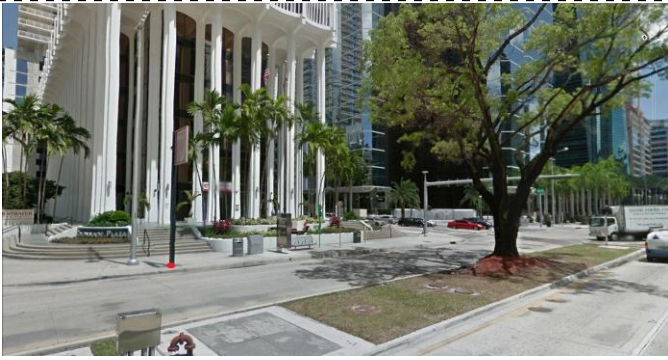

Sign Type: DistID.3

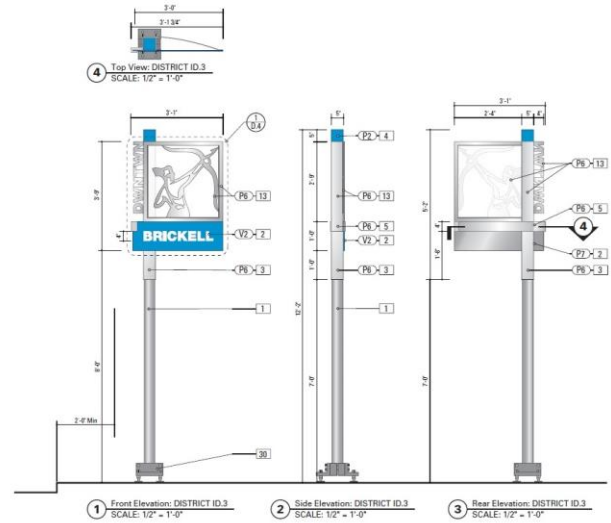

Sign Message:

Face A	Brickell District
Face B	None

Ground Condition: Concrete

Foundation Type: 5' 6" X 3' Diameter

Reference Intersection: SE 13th St @ Brickell Ave

Detailed Location: North of 13th St. Replace existing district sign

Orientation: EB

Right-of-Way Summary	Utilities Summary
City of Miami	Street Light Cable Comcast Cable

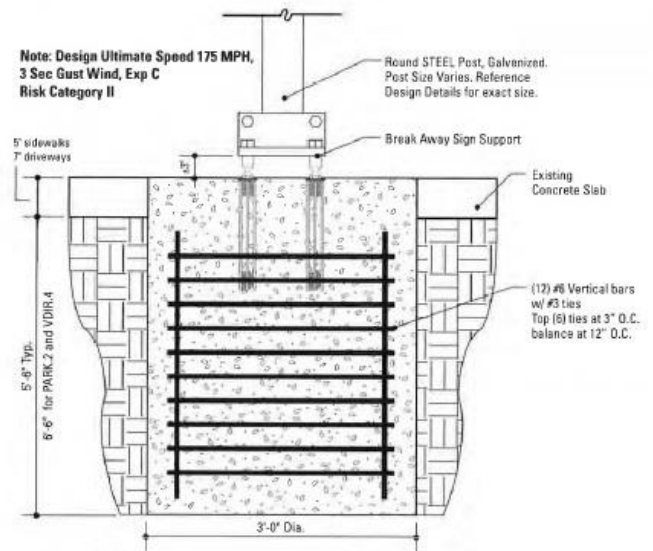

SPECIFIC PURPOSE SURVEY PROPOSED POLE 607

SURVEYOR'S REPORT :

- THE SPECIFIC PURPOSE OF THIS SURVEY IS TO SHOW THE LOCATION OF THE PROPOSED POLE IN RELATION TO THE MONUMENT LINES AND RIGHT-OF-WAY LINES.
- THIS IS NOT A BOUNDARY SURVEY
- THE LOCATION OF THE PROPOSED POLE SHOWN HEREON WAS PROVIDED BY THE CLIENT.
- THERE ARE EXISTING IMPROVEMENTS LYING WITHIN THE LIMITS OF THE SKETCH, WHICH ARE NOT SHOWN ON THIS SURVEY.
- REVIEW OF TITLE SEARCH WAS NOT PART OF THE SCOPE OF SERVICES.
- RIGHT-OF-WAY LINES AND MAPPED (ZONED) STREET LINES ARE AS PER CITY OF MIAMI ATLAS SHEET AND MIAMI-DADE COUNTY PLATS OF RECORD.
- POLE 607 LIES WITHIN THE JURISDICTION OF CITY OF MIAMI.
- INFORMATION REGARDING STREET JURISDICTION WAS TAKEN FROM MAP ENTITLED : DOWNTOWN MIAMI STREETS BY JURISDICTION PREPARED BY CITY OF MIAMI DATED SEPTEMBER 1, 2015 AND FURNISHED BY THE CLIENT.

SURVEYOR'S CERTIFICATION :

I HEREBY CERTIFY THAT THIS SPECIFIC PURPOSE SURVEY WAS PREPARED UNDER MY DIRECT SUPERVISION AND THAT IT IS TRUE AND CORRECT TO THE BEST OF MY KNOWLEDGE AND BELIEF AND I FURTHER CERTIFY THAT SAID SURVEY IS IN COMPLIANCE WITH THE STANDARDS OF PRACTICE AS SET FORTH BY THE FLORIDA BOARD OF LAND SURVEYORS AND MAPPERS IN CHAPTER 5J-17 FLORIDA ADMINISTRATIVE CODE PURSUANT TO SECTION 472.027 OF THE FLORIDA STATUTES.

 MANUEL G. VERA JR.
 PROFESSIONAL SURVEYOR AND MAPPER No. 5291
 STATE OF FLORIDA
 NOTICE: NOT VALID WITHOUT THE SIGNATURE AND ORIGINAL RAISED SEAL OF THE FLORIDA LICENSED SURVEYOR AND MAPPER.
 EACH SHEET AS INCORPORATED HEREIN SHALL NOT BE CONSIDERED FULL, VALID AND COMPLETE UNLESS ATTACHED TO THE OTHERS.

FOR SKETCH SEE SHEET 2

MANUEL G.VERA AND ASSOCIATES, INC.
 ENGINEERS-SURVEYORS & MAPPERS
 13960 S.W. 47th ST. MIAMI, FLORIDA 33175 L.B. No.2439
 PHONE: (305) 221-6210 e-mail: mverajr@mgvera.com

PROJECT NUMBER: 16-574		
TYPE OF PROJECT: SPECIFIC PURPOSE SURVEY		
PROJECT NAME: POLE LOCATION		
DATE: 06-27-2016	SCALE	SHEET
DRAWN BY: JCF	N.A.	1 OF 2

NOT A BOUNDARY SURVEY

SPECIFIC PURPOSE SURVEY PROPOSED POLE 607

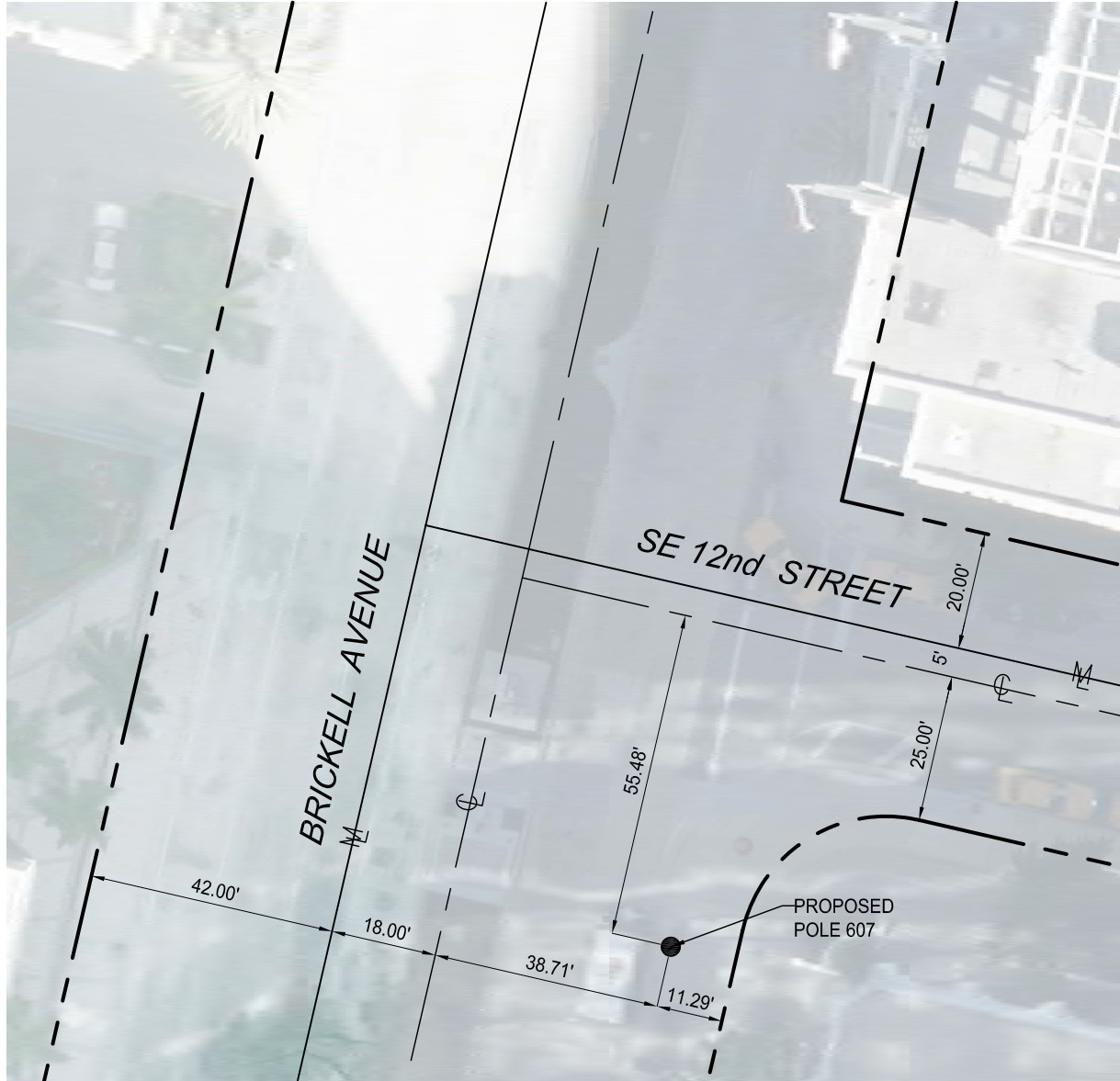
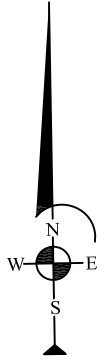

LEGEND:

- EXISTING RIGHT OF WAY LINE
- EXISTING LIMITED ACCESS RIGHT OF WAY LINE
- - - MAPPED (ZONED) STREET LINE
- ⊕ CENTER LINE
- M MONUMENT LINE

NOT A BOUNDARY SURVEY

MANUEL G.VERA AND ASSOCIATES, INC.
 ENGINEERS-SURVEYORS & MAPPERS
 13960 S.W. 47th ST. MIAMI, FLORIDA 33175 L.B. No.2439
 PHONE: (305) 221-6210 e-mail: mverajr@mgvera.com

PROJECT NUMBER: 16-574		
TYPE OF PROJECT: SPECIFIC PURPOSE SURVEY		
PROJECT NAME: POLE LOCATION		
DATE: 06-27-2016	SCALE	SHEET
DRAWN BY: JCF	1"=30'	2 OF 2



LOCATION DESCRIPTION:

Brickell Ave. S/O SE 12th St.

FOR EXACT SIGN POST LOCATION
PLEASE REFER TO ATTACHED
SPECIFIC PURPOSE SURVEY SKETCH

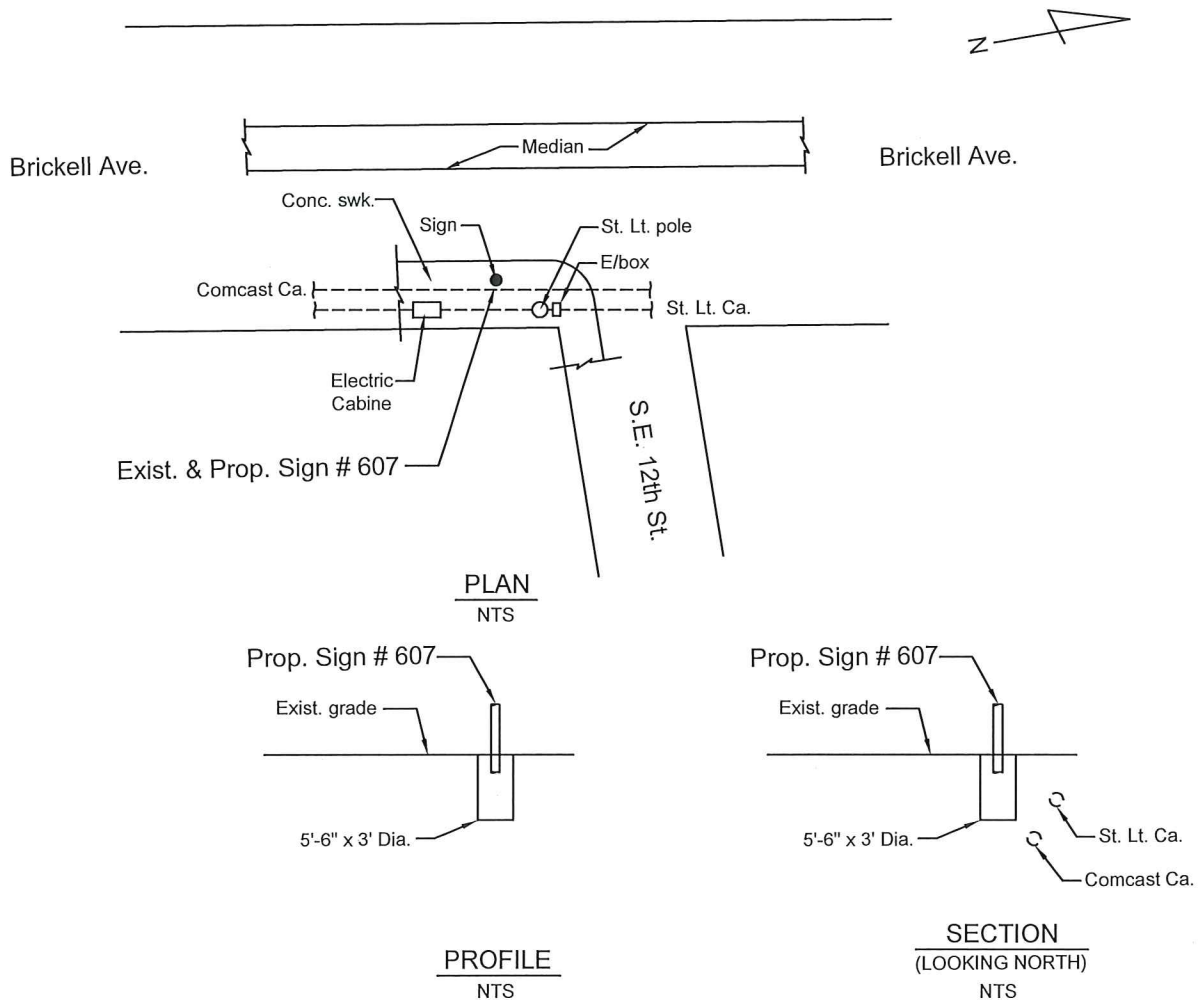

COMMENTS: Best Footer for Prop. Sign # 607 is: 5'-6" x 3' Dia.

MIAMI DDA - WAYFINDING AND SIGNAGE SYSTEM PROGRAM

DISCLAIMER:

This sketch has been prepared for utility coordination purposes only. This sketch is Not for Construction.

Utility coordination done by:
JRA Inc.
engineers-planners
10661 N Kendall Dr., Ste. 206B
Miami, FL 33176-1550
Phone 305-270-7800
CA 7613

CITY OF MIAMI

SIGN No. 607

Type Dist - ID.3

DATE: 03-28-2017

Sign No.
608



**Downtown
Miami District
ID Program**



Wayfinding & Signage System Program

Downtown Miami, Florida

SIGN NO. 608

Location Aerial View:



Location Photo:

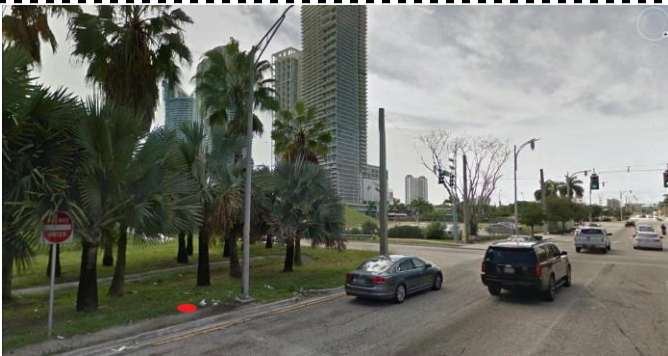

Reference Intersection: NE 13th St @ Bayshore Dr

Detailed Location: 8' west of lamppost in photo

Orientation: WB

Right-of-Way Summary	Utilities Summary
City of Miami	Street Light Cable Fiber Optic Cable Sanitary Sewer Water Main

Sign Type: DistID.3

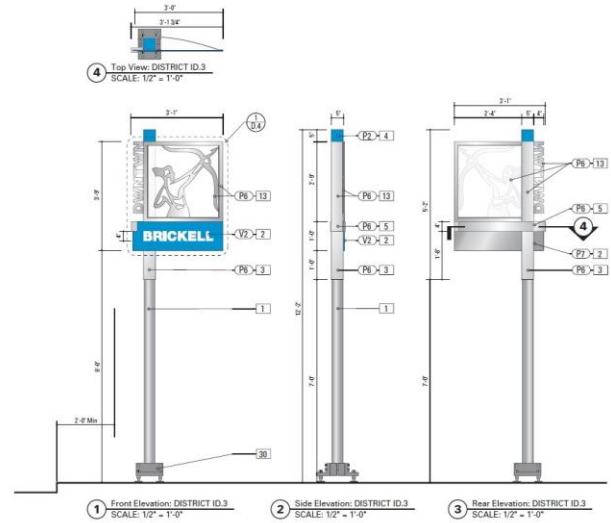

Sign Message:

Face A	Arts & Entertainment
Face B	None

Ground Condition: Grass

Foundation Type: 2' X 3' 10" Square

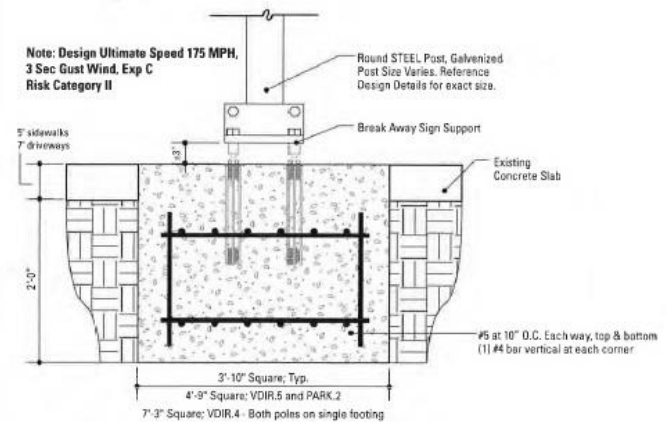

SPECIFIC PURPOSE SURVEY PROPOSED POLES 608

SURVEYOR'S REPORT :

- THE SPECIFIC PURPOSE OF THIS SURVEY IS TO SHOW THE LOCATION OF THE PROPOSED POLE IN RELATION TO THE MONUMENT LINES AND RIGHT-OF-WAY LINES.
- THIS IS NOT A BOUNDARY SURVEY
- THE LOCATION OF THE PROPOSED POLE SHOWN HEREON WAS PROVIDED BY THE CLIENT.
- THERE ARE EXISTING IMPROVEMENTS LYING WITHIN THE LIMITS OF THE SKETCH, WHICH ARE NOT SHOWN ON THIS SURVEY.
- REVIEW OF TITLE SEARCH WAS NOT PART OF THE SCOPE OF SERVICES.
- RIGHT-OF-WAY LINES AND MAPPED (ZONED) STREET LINES ARE AS PER CITY OF MIAMI ATLAS SHEET AND MIAMI-DADE COUNTY PLATS OF RECORD.
- POLE 608 LIES WITHIN THE JURISDICTION OF CITY OF MIAMI.
- INFORMATION REGARDING STREET JURISDICTION WAS TAKEN FROM MAP ENTITLED : DOWNTOWN MIAMI STREETS BY JURISDICTION PREPARED BY CITY OF MIAMI DATED SEPTEMBER 1, 2015 AND FURNISHED BY THE CLIENT.

SURVEYOR'S CERTIFICATION :

I HEREBY CERTIFY THAT THIS SPECIFIC PURPOSE SURVEY WAS PREPARED UNDER MY DIRECT SUPERVISION AND THAT IT IS TRUE AND CORRECT TO THE BEST OF MY KNOWLEDGE AND BELIEF AND I FURTHER CERTIFY THAT SAID SURVEY IS IN COMPLIANCE WITH THE STANDARDS OF PRACTICE AS SET FORTH BY THE FLORIDA BOARD OF LAND SURVEYORS AND MAPPERS IN CHAPTER 5J-17 FLORIDA ADMINISTRATIVE CODE PURSUANT TO SECTION 472.027 OF THE FLORIDA STATUTES.

 MANUEL G. VERA JR.
 PROFESSIONAL SURVEYOR AND MAPPER No. 5291
 STATE OF FLORIDA
 NOTICE: NOT VALID WITHOUT THE SIGNATURE AND ORIGINAL RAISED SEAL OF THE FLORIDA LICENSED SURVEYOR AND MAPPER.
 EACH SHEET AS INCORPORATED HEREIN SHALL NOT BE CONSIDERED FULL, VALID AND COMPLETE UNLESS ATTACHED TO THE OTHERS.

FOR SKETCH SEE SHEET 2

MANUEL G.VERA AND ASSOCIATES, INC.
 ENGINEERS-SURVEYORS & MAPPERS
 13960 S.W. 47th ST. MIAMI, FLORIDA 33175 L.B. No.2439
 PHONE: (305) 221-6210 e-mail: mverajr@mgvera.com

PROJECT NUMBER: 16-574		
TYPE OF PROJECT: SPECIFIC PURPOSE SURVEY		
PROJECT NAME: POLE LOCATION		
DATE: 07-11-2016	SCALE	SHEET
DRAWN BY: JCF	N.A.	1 OF 2

NOT A BOUNDARY SURVEY

SPECIFIC PURPOSE SURVEY PROPOSED POLE 608

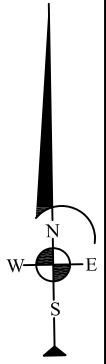

LEGEND:

- EXISTING RIGHT OF WAY LINE
- //--- EXISTING LIMITED ACCESS RIGHT OF WAY LINE
- - - MAPPED (ZONED) STREET LINE
- ⊕ CENTER LINE
- M MONUMENT LINE

ABBREVIATIONS:

- SR - STATE ROAD
- US - UNITED STATE HIGHWAY

NOT A BOUNDARY SURVEY

MANUEL G.VERA AND ASSOCIATES, INC.
 ENGINEERS-SURVEYORS & MAPPERS
 13960 S.W. 47th ST. MIAMI, FLORIDA 33175 L.B. No.2439
 PHONE: (305) 221-6210 e-mail: mverajr@mgvera.com

PROJECT NUMBER: 16-574		
TYPE OF PROJECT: SPECIFIC PURPOSE SURVEY		
PROJECT NAME: POLE LOCATION		
DATE: 07-11-2016	SCALE	SHEET
DRAWN BY: JCF	1"=30'	2 OF 2



LOCATION DESCRIPTION:

NE 13th St E/O N Bayshore Dr.

FOR EXACT SIGN POST LOCATION
PLEASE REFER TO ATTACHED
SPECIFIC PURPOSE SURVEY SKETCH

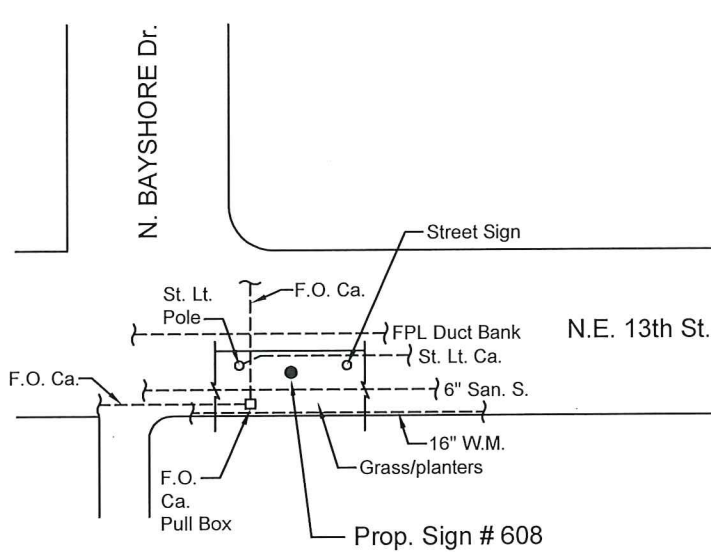

PLAN
NTS

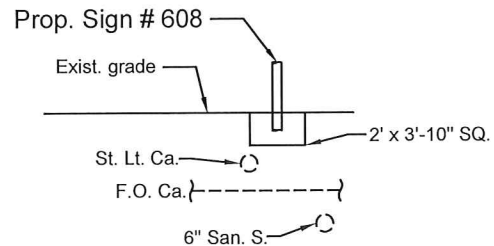
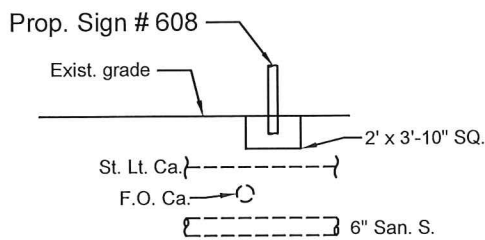

PROFILE
NTS

SECTION
(LOOKING EAST)
NTS

COMMENTS: Best Footer for Prop. Sign # 608 is: 2' x 3'-10" SQ.

MIAMI DDA - WAYFINDING AND SIGNAGE SYSTEM PROGRAM

DISCLAIMER:

This sketch has been prepared
for utility coordination purposes only.
This sketch is Not for Construction.

Utility coordination done by:
JRA Inc.
engineers-planners
10661 N Kendall Dr., Ste. 206B
Miami, FL 33176-1550
Phone 305-270-7800
CA 7613

CITY OF MIAMI

SIGN No. 608

Type Dist - ID.3

DATE: 03-28-2017

Sign No.
611B



Downtown
Miami District
ID Program



Wayfinding & Signage System Program

Downtown Miami, Florida

SIGN NO. 611B

Location Aerial View:



Location Photo:

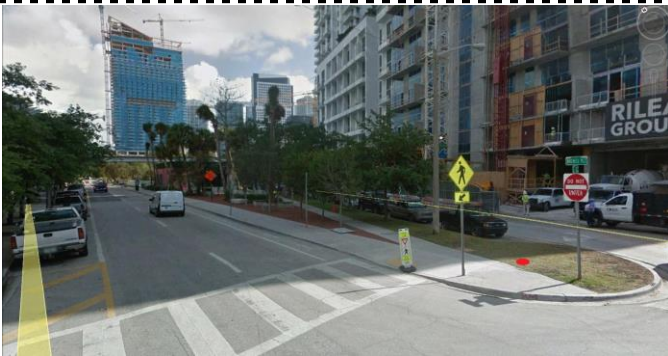

Reference Intersection: S Miami Ave @ SE 12th St

Detailed Location: 8' north of curb, in grass parallel with stop sign to avoid line of sight conflict

Orientation: NB

Right-of-Way Summary	Utilities Summary
City of Miami	AT&T Sanitary Sewer MCI/Verizon F.O.

Sign Type: DistID.3

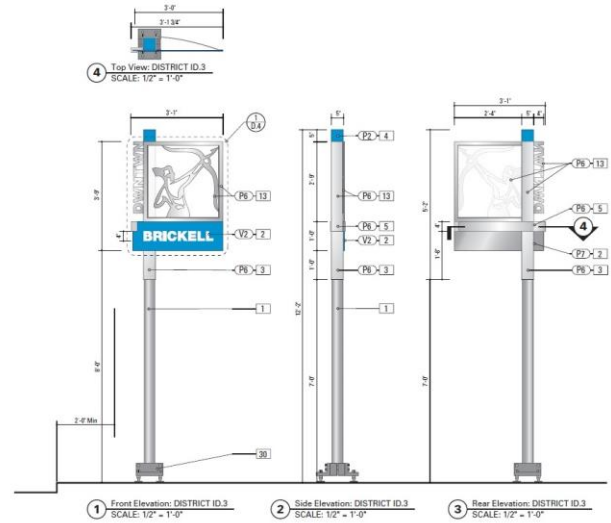

Sign Message:

Face A	Brickell District
Face B	None

Ground Condition: Grass

Foundation Type: 5' 6" X 3' Diameter

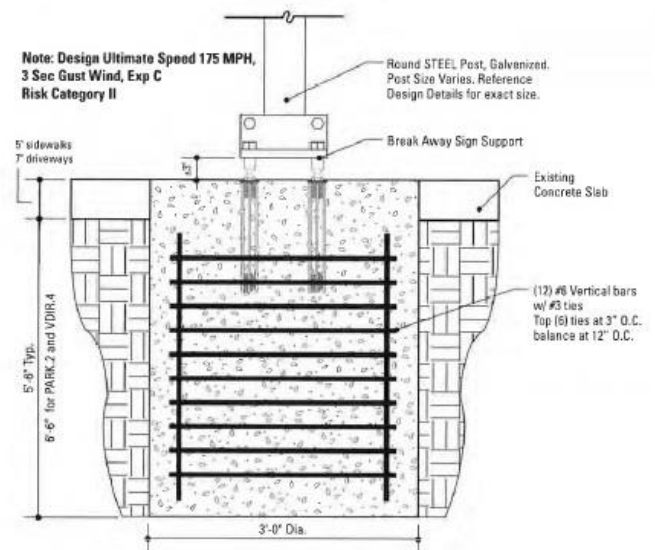

SPECIFIC PURPOSE SURVEY PROPOSED POLE 611B

SURVEYOR'S REPORT :

- THE SPECIFIC PURPOSE OF THIS SURVEY IS TO SHOW THE LOCATION OF THE PROPOSED POLE IN RELATION TO THE MONUMENT LINES AND RIGHT-OF-WAY LINES.
- THIS IS NOT A BOUNDARY SURVEY
- THE LOCATION OF THE PROPOSED POLE SHOWN HEREON WAS PROVIDED BY THE CLIENT.
- THERE ARE EXISTING IMPROVEMENTS LYING WITHIN THE LIMITS OF THE SKETCH, WHICH ARE NOT SHOWN ON THIS SURVEY.
- REVIEW OF TITLE SEARCH WAS NOT PART OF THE SCOPE OF SERVICES.
- RIGHT-OF-WAY LINES AND MAPPED (ZONED) STREET LINES ARE AS PER CITY OF MIAMI ATLAS SHEET AND MIAMI-DADE COUNTY PLATS OF RECORD.
- POLE 611B LIES WITHIN THE JURISDICTION OF CITY OF MIAMI.
- INFORMATION REGARDING STREET JURISDICTION WAS TAKEN FROM MAP ENTITLED : DOWNTOWN MIAMI STREETS BY JURISDICTION PREPARED BY CITY OF MIAMI DATED SEPTEMBER 1, 2015 AND FURNISHED BY THE CLIENT.

SURVEYOR'S CERTIFICATION :

I HEREBY CERTIFY THAT THIS SPECIFIC PURPOSE SURVEY WAS PREPARED UNDER MY DIRECT SUPERVISION AND THAT IT IS TRUE AND CORRECT TO THE BEST OF MY KNOWLEDGE AND BELIEF AND I FURTHER CERTIFY THAT SAID SURVEY IS IN COMPLIANCE WITH THE STANDARDS OF PRACTICE AS SET FORTH BY THE FLORIDA BOARD OF LAND SURVEYORS AND MAPPERS IN CHAPTER 5J-17 FLORIDA ADMINISTRATIVE CODE PURSUANT TO SECTION 472.027 OF THE FLORIDA STATUTES.

 MANUEL G. VERA JR.
 PROFESSIONAL SURVEYOR AND MAPPER No. 5291
 STATE OF FLORIDA
 NOTICE: NOT VALID WITHOUT THE SIGNATURE AND ORIGINAL RAISED SEAL OF THE FLORIDA LICENSED SURVEYOR AND MAPPER.
 EACH SHEET AS INCORPORATED HEREIN SHALL NOT BE CONSIDERED FULL, VALID AND COMPLETE UNLESS ATTACHED TO THE OTHERS.

FOR SKETCH SEE SHEET 2

MANUEL G.VERA AND ASSOCIATES, INC.
 ENGINEERS-SURVEYORS & MAPPERS
 13960 S.W. 47th ST. MIAMI, FLORIDA 33175 L.B. No.2439
 PHONE: (305) 221-6210 e-mail: mverajr@mgvera.com

PROJECT NUMBER: 16-574		
TYPE OF PROJECT: SPECIFIC PURPOSE SURVEY		
PROJECT NAME: POLE LOCATION		
DATE: 06-28-2016	SCALE	SHEET
DRAWN BY: JCF	N.A.	1 OF 2

NOT A BOUNDARY SURVEY

SPECIFIC PURPOSE SURVEY PROPOSED POLE 611B

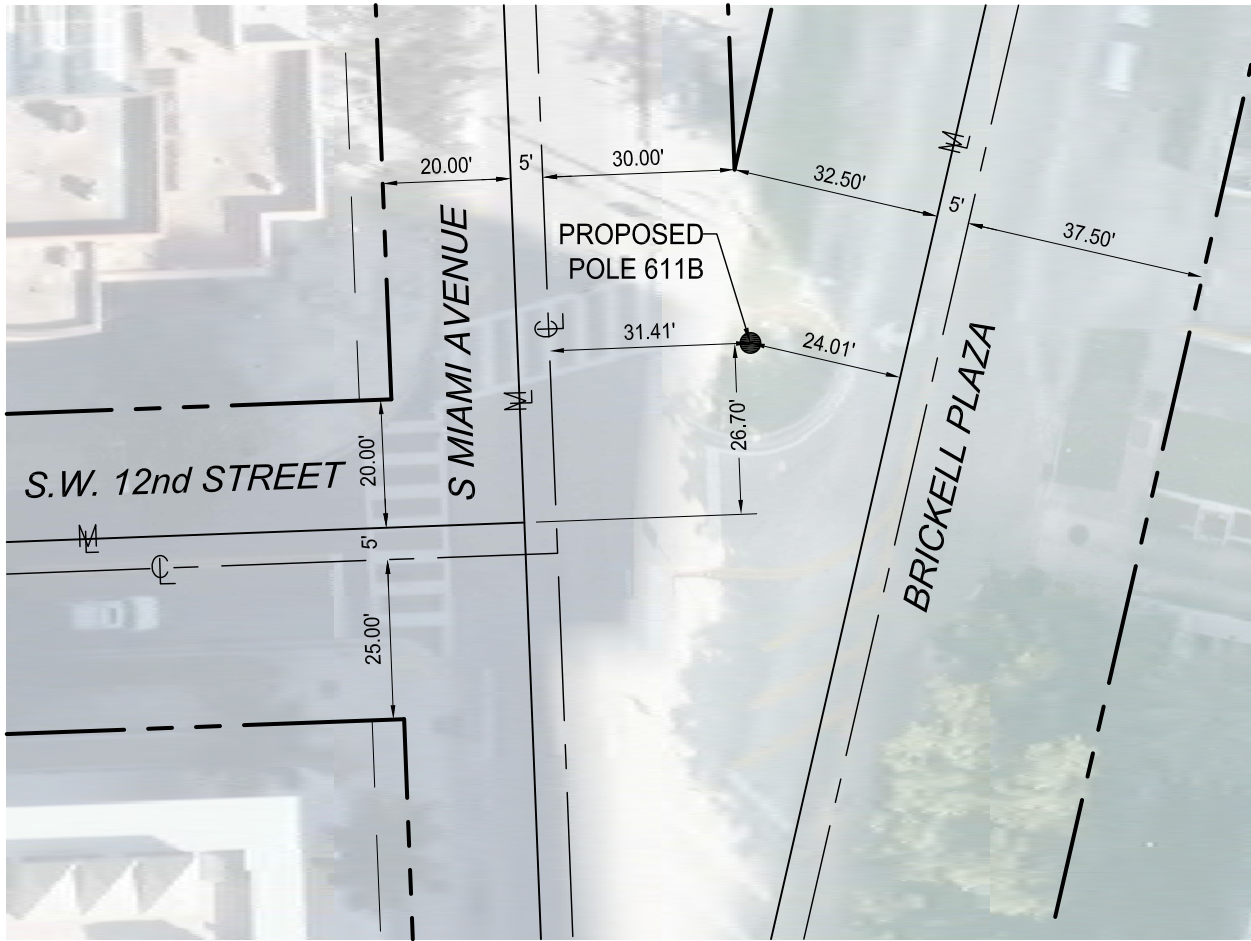
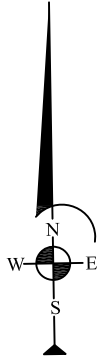
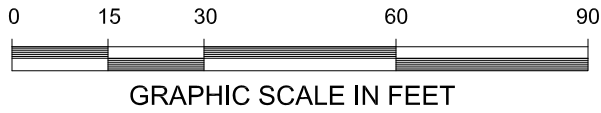

LEGEND:

- EXISTING RIGHT OF WAY LINE
- - - MAPPED (ZONED) STREET LINE
- ⊕ CENTER LINE
- M MONUMENT LINE

MANUEL G.VERA AND ASSOCIATES, INC.
 ENGINEERS-SURVEYORS & MAPPERS
 13960 S.W. 47th ST. MIAMI, FLORIDA 33175 L.B. No.2439
 PHONE: (305) 221-6210 e-mail: mverajr@mgvera.com

NOT A BOUNDARY SURVEY

PROJECT NUMBER: 16-574		
TYPE OF PROJECT: SPECIFIC PURPOSE SURVEY		
PROJECT NAME: POLE LOCATION		
DATE: 06-28-2016	SCALE	SHEET
DRAWN BY: JCF	1"=30'	2 OF 2

Z:\DESIGN 2016\16574_of_City_of_Miami_Pole_Locations\ACAD_SKETCH\16_574_POLE_611B.dwg



LOCATION DESCRIPTION:

S Miami Ave N/O SW 12th St.

FOR EXACT SIGN POST LOCATION
PLEASE REFER TO ATTACHED
SPECIFIC PURPOSE SURVEY SKETCH

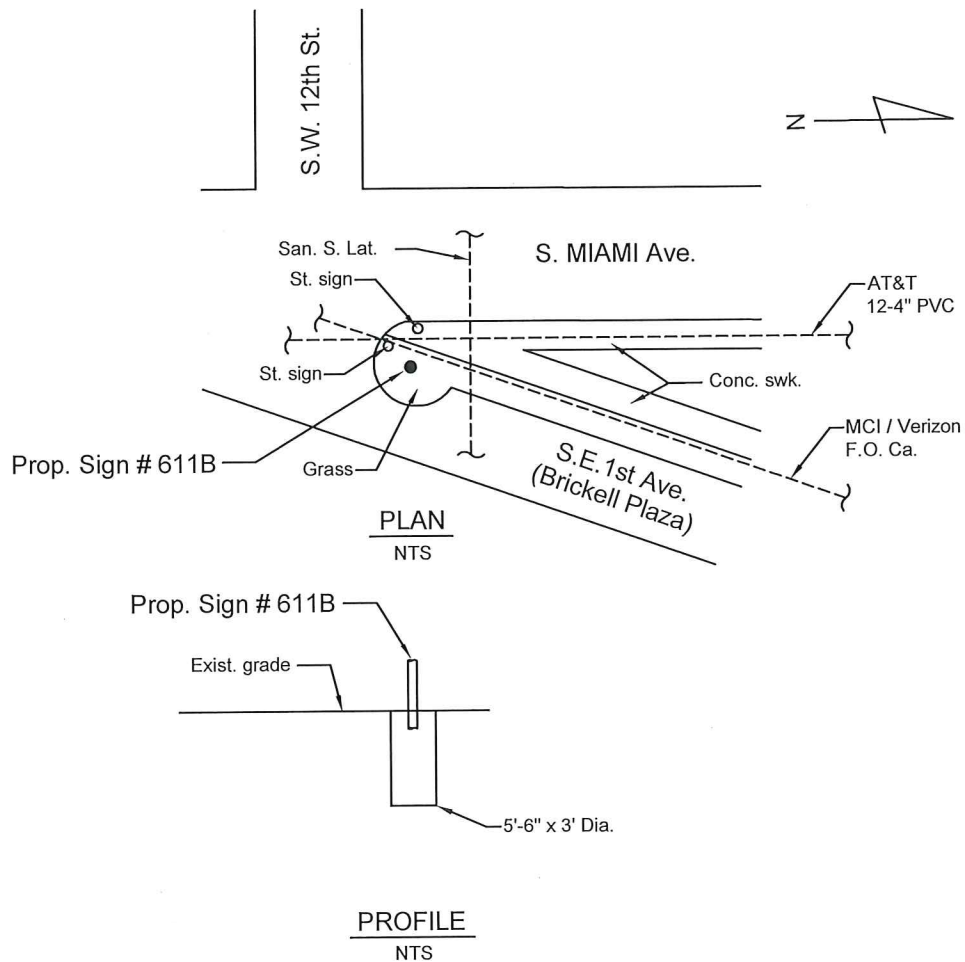

COMMENTS: Best Footer for Prop. Sign # 611B is: 5'-6" x 3' Dia.

MIAMI DDA - WAYFINDING AND SIGNAGE SYSTEM PROGRAM

DISCLAIMER:

This sketch has been prepared for utility coordination purposes only. This sketch is Not for Construction.

Utility coordination done by:
JRA Inc.
engineers-planners
10661 N Kendall Dr., Ste. 206B
Miami, FL 33176-1550
Phone 305-270-7800
CA 7613

CITY OF MIAMI

SIGN No. 611B

Type Dist - ID.3

DATE: 03-28-2017

Sign No.
612



Downtown
Miami District
ID Program

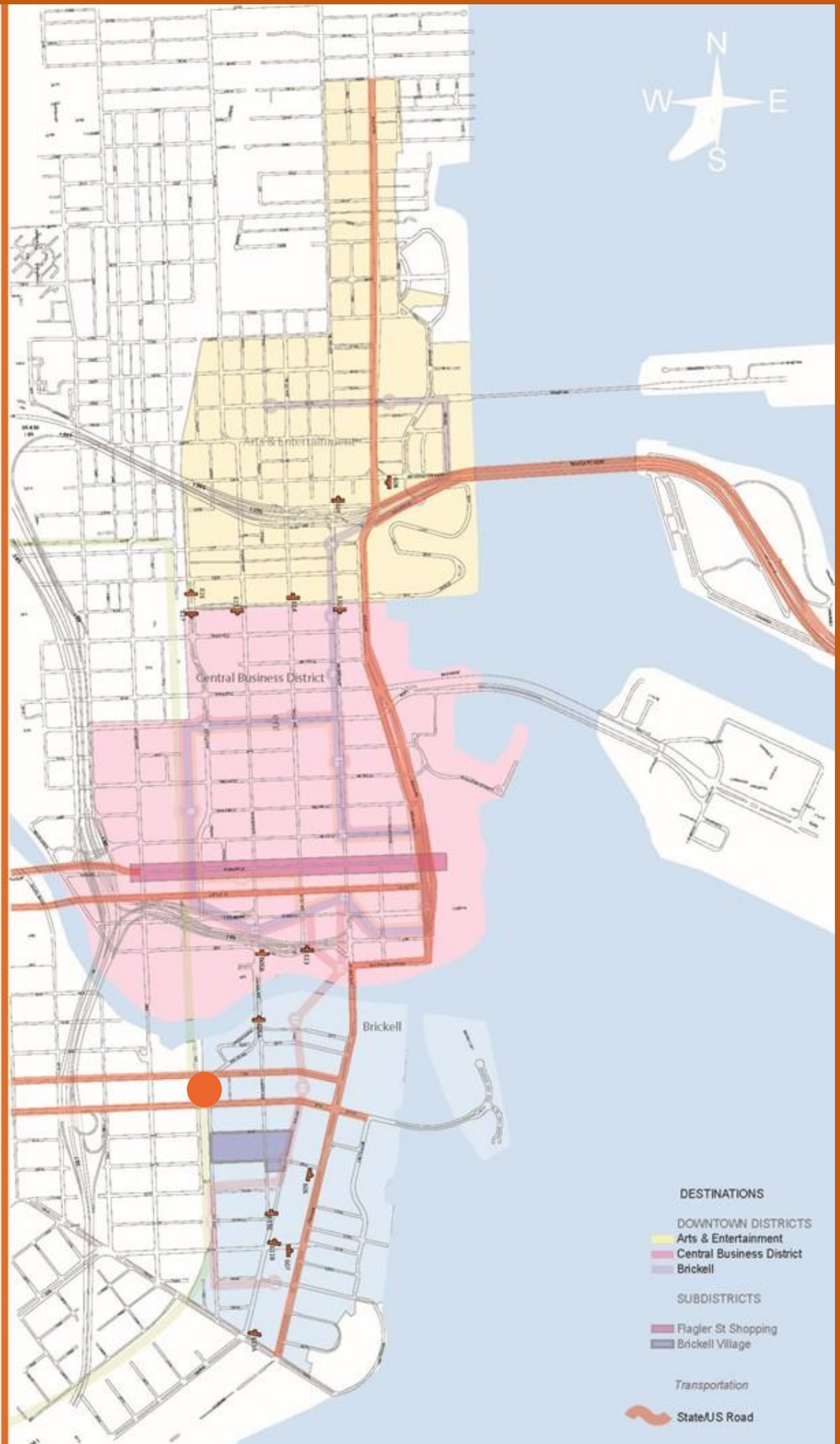

Wayfinding & Signage System Program

Downtown Miami, Florida

SIGN NO. 612

Location Aerial View:



Location Photo:



Reference Intersection: SW 1st Ave @ SW 7th St

Detailed Location: Edge of concrete, where sidewalk begins to widen at turn

Orientation: SB

Right-of-Way Summary	Utilities Summary
City of Miami (MetroRail ROW)	ATT PVC

Sign Type: DistID.3

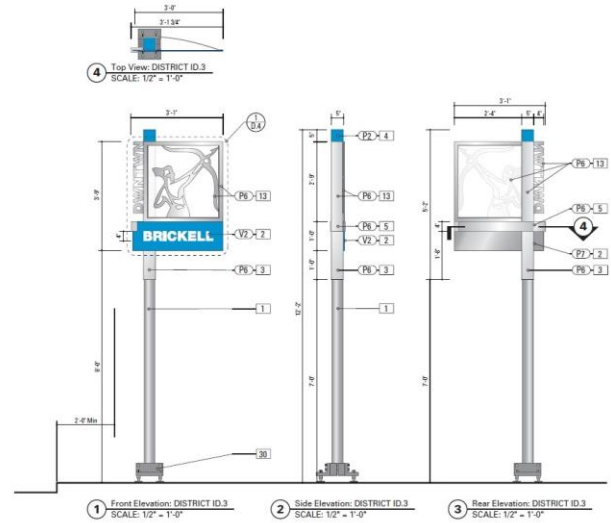

Sign Message:

Face A	Brickell District
Face B	None

Ground Condition: Concrete

Foundation Type: 5' 6" X 3' Diameter

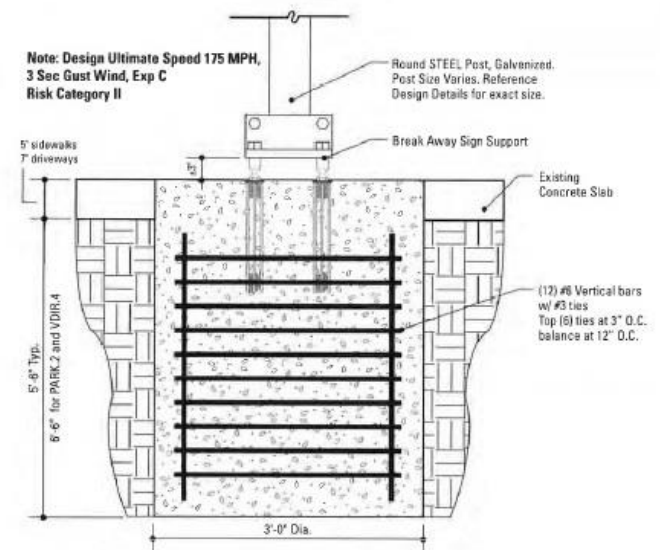

SPECIFIC PURPOSE SURVEY PROPOSED POLE 612

SURVEYOR'S REPORT :

- THE SPECIFIC PURPOSE OF THIS SURVEY IS TO SHOW THE LOCATION OF THE PROPOSED POLE IN RELATION TO THE MONUMENT LINES AND RIGHT-OF-WAY LINES.
- THIS IS NOT A BOUNDARY SURVEY
- THE LOCATION OF THE PROPOSED POLE SHOWN HEREON WAS PROVIDED BY THE CLIENT.
- THERE ARE EXISTING IMPROVEMENTS LYING WITHIN THE LIMITS OF THE SKETCH, WHICH ARE NOT SHOWN ON THIS SURVEY.
- REVIEW OF TITLE SEARCH WAS NOT PART OF THE SCOPE OF SERVICES.
- RIGHT-OF-WAY LINES AND MAPPED (ZONED) STREET LINES ARE AS PER CITY OF MIAMI ATLAS SHEET AND MIAMI-DADE COUNTY PLATS OF RECORD.
- POLE 612 LIES WITHIN THE JURISDICTION OF CITY OF MIAMI.
- INFORMATION REGARDING STREET JURISDICTION WAS TAKEN FROM MAP ENTITLED : DOWNTOWN MIAMI STREETS BY JURISDICTION PREPARED BY CITY OF MIAMI DATED SEPTEMBER 1, 2015 AND FURNISHED BY THE CLIENT.

SURVEYOR'S CERTIFICATION :

I HEREBY CERTIFY THAT THIS SPECIFIC PURPOSE SURVEY WAS PREPARED UNDER MY DIRECT SUPERVISION AND THAT IT IS TRUE AND CORRECT TO THE BEST OF MY KNOWLEDGE AND BELIEF AND I FURTHER CERTIFY THAT SAID SURVEY IS IN COMPLIANCE WITH THE STANDARDS OF PRACTICE AS SET FORTH BY THE FLORIDA BOARD OF LAND SURVEYORS AND MAPPERS IN CHAPTER 5J-17 FLORIDA ADMINISTRATIVE CODE PURSUANT TO SECTION 472.027 OF THE FLORIDA STATUTES.

 MANUEL G. VERA JR.
 PROFESSIONAL SURVEYOR AND MAPPER No. 5291
 STATE OF FLORIDA
 NOTICE: NOT VALID WITHOUT THE SIGNATURE AND ORIGINAL RAISED SEAL OF THE FLORIDA LICENSED SURVEYOR AND MAPPER.
 EACH SHEET AS INCORPORATED HEREIN SHALL NOT BE CONSIDERED FULL, VALID AND COMPLETE UNLESS ATTACHED TO THE OTHERS.

FOR SKETCH SEE SHEET 2

MANUEL G.VERA AND ASSOCIATES, INC.
 ENGINEERS-SURVEYORS & MAPPERS
 13960 S.W. 47th ST. MIAMI, FLORIDA 33175 L.B. No.2439
 PHONE: (305) 221-6210 e-mail: mverajr@mgvera.com

PROJECT NUMBER: 16-574		
TYPE OF PROJECT: SPECIFIC PURPOSE SURVEY		
PROJECT NAME: POLE LOCATION		
DATE: 07-27-2016	SCALE	SHEET
DRAWN BY: JCF	N.A.	1 OF 2

NOT A BOUNDARY SURVEY

SPECIFIC PURPOSE SURVEY PROPOSED POLE 612

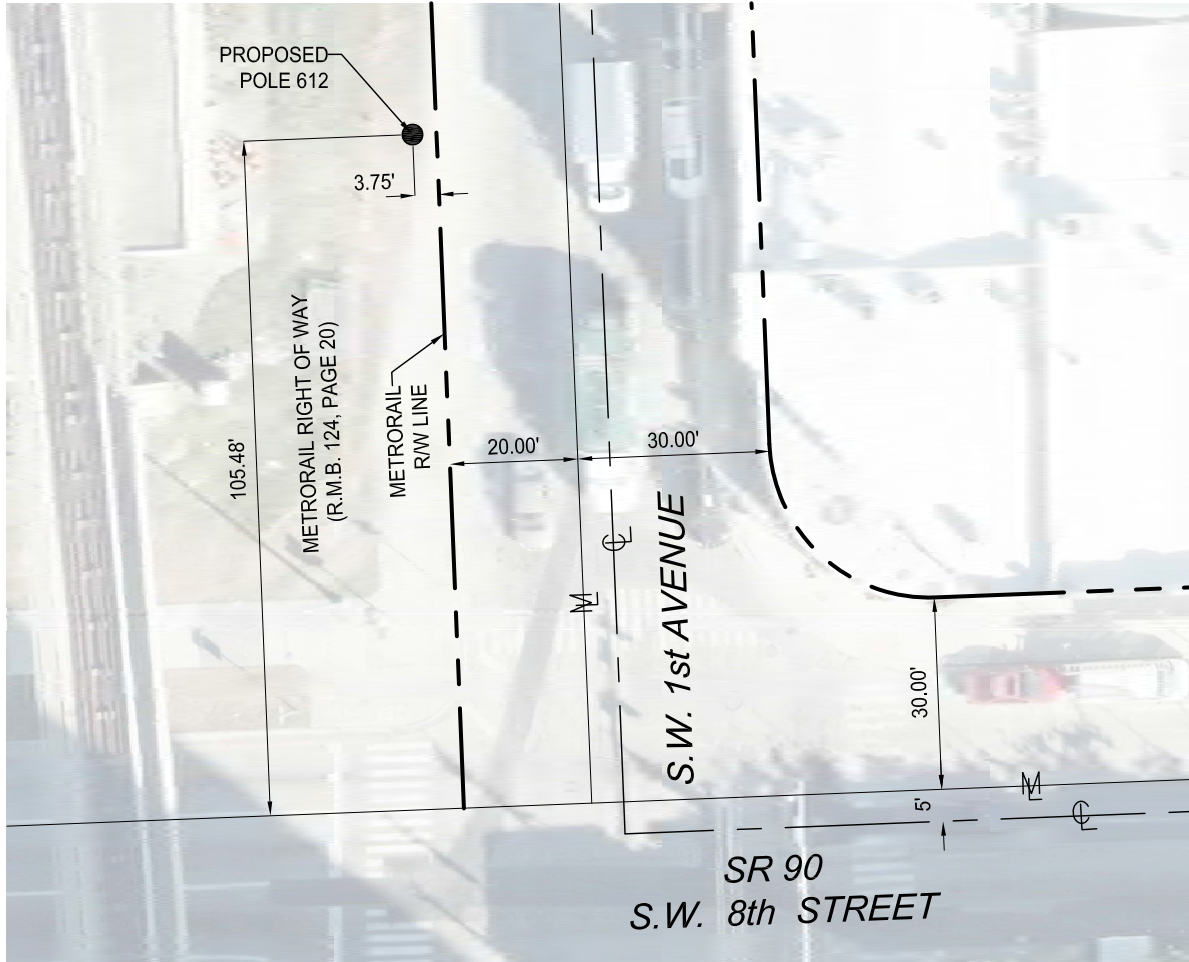
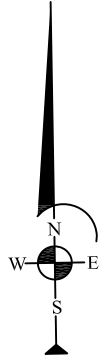
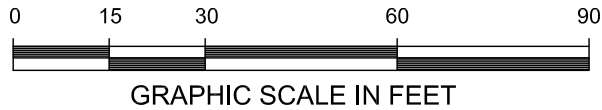

LEGEND:

- EXISTING RIGHT OF WAY LINE
- EXISTING LIMITED ACCESS RIGHT OF WAY LINE
- - - MAPPED (ZONED) STREET LINE
- ⊕ CENTER LINE
- M MONUMENT LINE

ABBREVIATIONS:

- R.M.B. -RIGHT OF WAY MAP BOOK
- SR -STATE ROAD

NOT A BOUNDARY SURVEY

MANUEL G.VERA AND ASSOCIATES, INC.
ENGINEERS-SURVEYORS & MAPPERS
 13960 S.W. 47th ST. MIAMI, FLORIDA 33175 L.B. No.2439
 PHONE: (305) 221-6210 e-mail: mverajr@mgvera.com

PROJECT NUMBER: 16-574		
TYPE OF PROJECT: SPECIFIC PURPOSE SURVEY		
PROJECT NAME: POLE LOCATION		
DATE: 07-27-2016	SCALE	SHEET
DRAWN BY: JCF	1"=30'	2 OF 2



LOCATION DESCRIPTION:

SW 1st Ave N/O SW 8th St

FOR EXACT SIGN POST LOCATION
PLEASE REFER TO ATTACHED
SPECIFIC PURPOSE SURVEY SKETCH

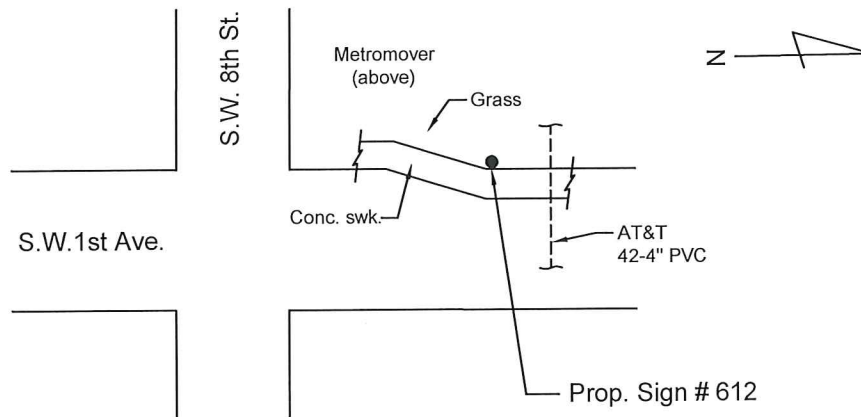

PLAN
NTS

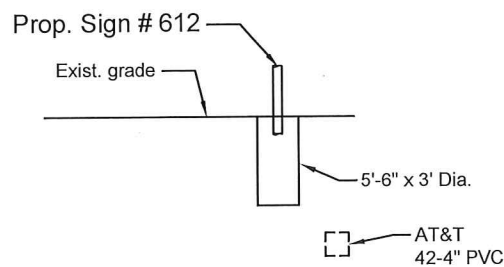

PROFILE
NTS

COMMENTS: Best Footer for Prop. Sign # 612 is: 5'-6" x 3' Dia.

MIAMI DDA - WAYFINDING AND SIGNAGE SYSTEM PROGRAM

DISCLAIMER:

This sketch has been prepared
for utility coordination purposes only.
This sketch is Not for Construction.

Utility coordination done by:
JRA Inc.
engineers-planners
10661 N Kendall Dr., Ste. 206B
Miami, FL 33176-1550
Phone 305-270-7800
CA 7613

CITY OF MIAMI

SIGN No. 612

Type Dist - ID.3

DATE: 03-28-2017

Sign No.
613



**Downtown
Miami District
ID Program**

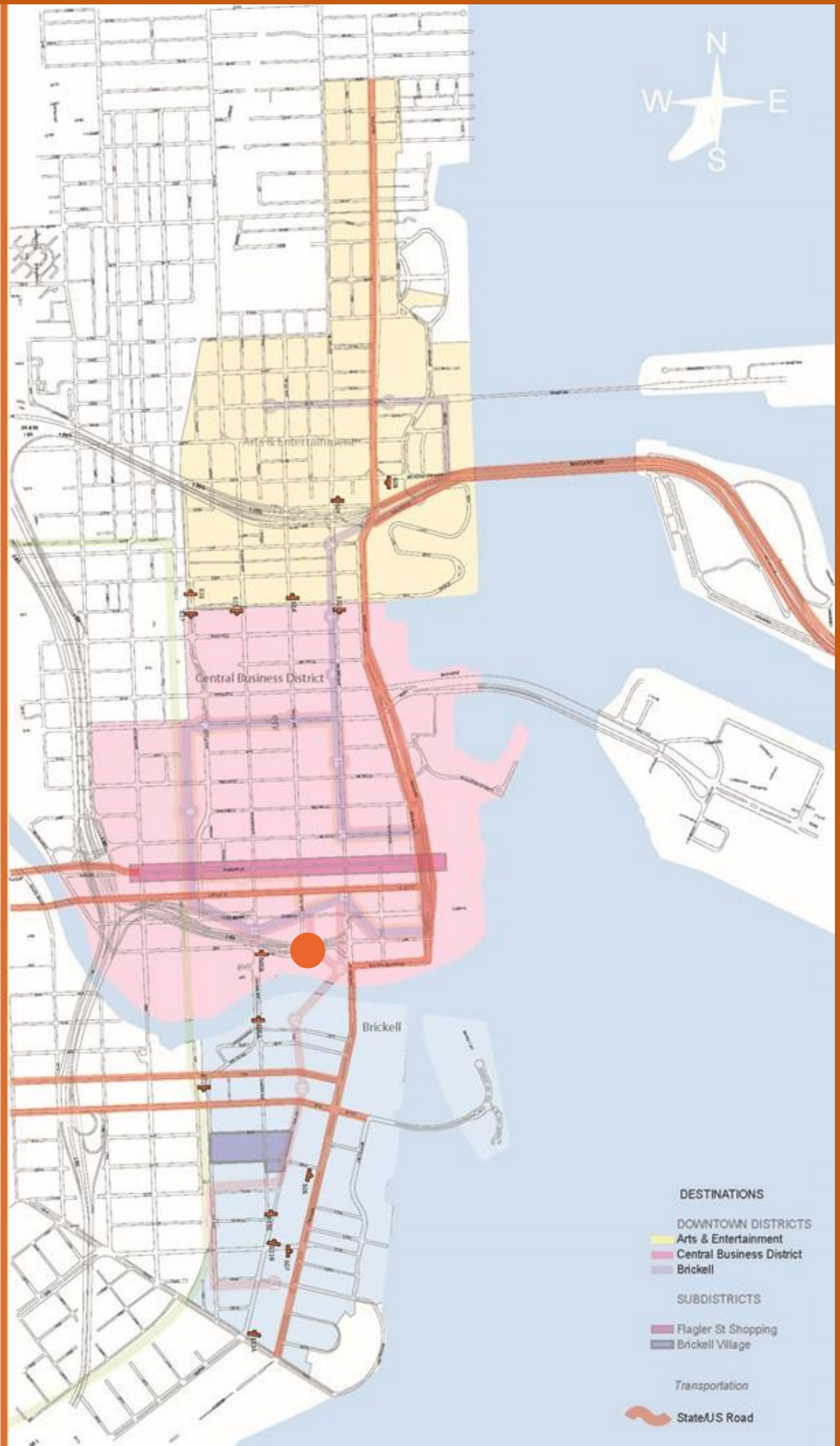

Wayfinding & Signage System Program

Downtown Miami, Florida

SIGN NO. 613

Location Aerial View:



Location Photo:



Reference Intersection: SE 1st Ave @ SE 4th St

Detailed Location: In planter area of MPA lot

Orientation: NB

Right-of-Way Summary	Utilities Summary
City of Miami	FPL Duct Bank Storm Sewer

Sign Type: DistID.3

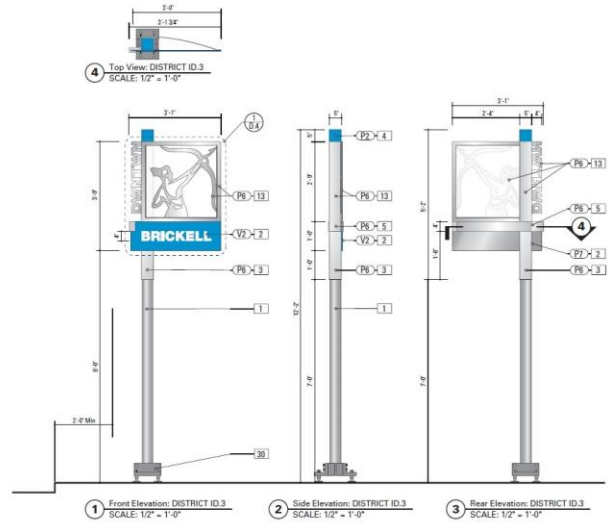

Sign Message:

Face A	Central Business District
Face B	None

Ground Condition: Grass

Foundation Type: 2' X 3' 10" Square

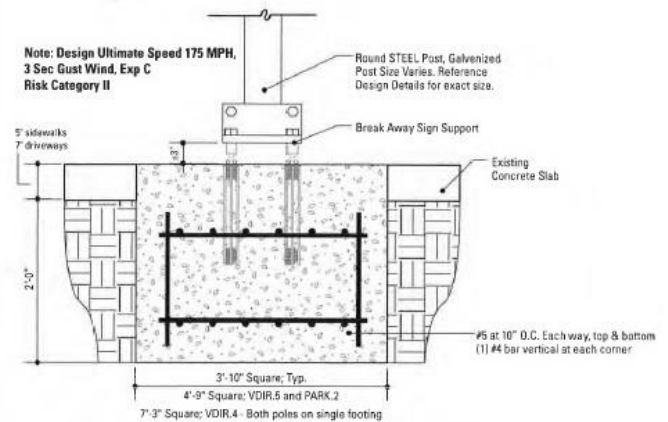

SPECIFIC PURPOSE SURVEY PROPOSED POLE 613

SURVEYOR'S REPORT :

- THE SPECIFIC PURPOSE OF THIS SURVEY IS TO SHOW THE LOCATION OF THE PROPOSED POLE IN RELATION TO THE MONUMENT LINES AND RIGHT-OF-WAY LINES.
- THIS IS NOT A BOUNDARY SURVEY
- THE LOCATION OF THE PROPOSED POLE SHOWN HEREON WAS PROVIDED BY THE CLIENT.
- THERE ARE EXISTING IMPROVEMENTS LYING WITHIN THE LIMITS OF THE SKETCH, WHICH ARE NOT SHOWN ON THIS SURVEY.
- REVIEW OF TITLE SEARCH WAS NOT PART OF THE SCOPE OF SERVICES.
- RIGHT-OF-WAY LINES AND MAPPED (ZONED) STREET LINES ARE AS PER CITY OF MIAMI ATLAS SHEET AND MIAMI-DADE COUNTY PLATS OF RECORD.
- POLE 613 LIES WITHIN THE JURISDICTION OF CITY OF MIAMI.
- INFORMATION REGARDING STREET JURISDICTION WAS TAKEN FROM MAP ENTITLED : DOWNTOWN MIAMI STREETS BY JURISDICTION PREPARED BY CITY OF MIAMI DATED SEPTEMBER 1, 2015 AND FURNISHED BY THE CLIENT.

SURVEYOR'S CERTIFICATION :

I HEREBY CERTIFY THAT THIS SPECIFIC PURPOSE SURVEY WAS PREPARED UNDER MY DIRECT SUPERVISION AND THAT IT IS TRUE AND CORRECT TO THE BEST OF MY KNOWLEDGE AND BELIEF AND I FURTHER CERTIFY THAT SAID SURVEY IS IN COMPLIANCE WITH THE STANDARDS OF PRACTICE AS SET FORTH BY THE FLORIDA BOARD OF LAND SURVEYORS AND MAPPERS IN CHAPTER 5J-17 FLORIDA ADMINISTRATIVE CODE PURSUANT TO SECTION 472.027 OF THE FLORIDA STATUTES.

 MANUEL G. VERA JR.
 PROFESSIONAL SURVEYOR AND MAPPER No. 5291
 STATE OF FLORIDA
 NOTICE: NOT VALID WITHOUT THE SIGNATURE AND ORIGINAL RAISED SEAL OF THE FLORIDA LICENSED SURVEYOR AND MAPPER.
 EACH SHEET AS INCORPORATED HEREIN SHALL NOT BE CONSIDERED FULL, VALID AND COMPLETE UNLESS ATTACHED TO THE OTHERS.

FOR SKETCH SEE SHEET 2

MANUEL G.VERA AND ASSOCIATES, INC.
 ENGINEERS-SURVEYORS & MAPPERS
 13960 S.W. 47th ST. MIAMI, FLORIDA 33175 L.B. No.2439
 PHONE: (305) 221-6210 e-mail: mverajr@mgvera.com

PROJECT NUMBER: 16-574		
TYPE OF PROJECT: SPECIFIC PURPOSE SURVEY		
PROJECT NAME: POLE LOCATION		
DATE: 08-3-2016	SCALE	SHEET
DRAWN BY: JCF	N.A.	1 OF 2

NOT A BOUNDARY SURVEY

SPECIFIC PURPOSE SURVEY PROPOSED POLE 613

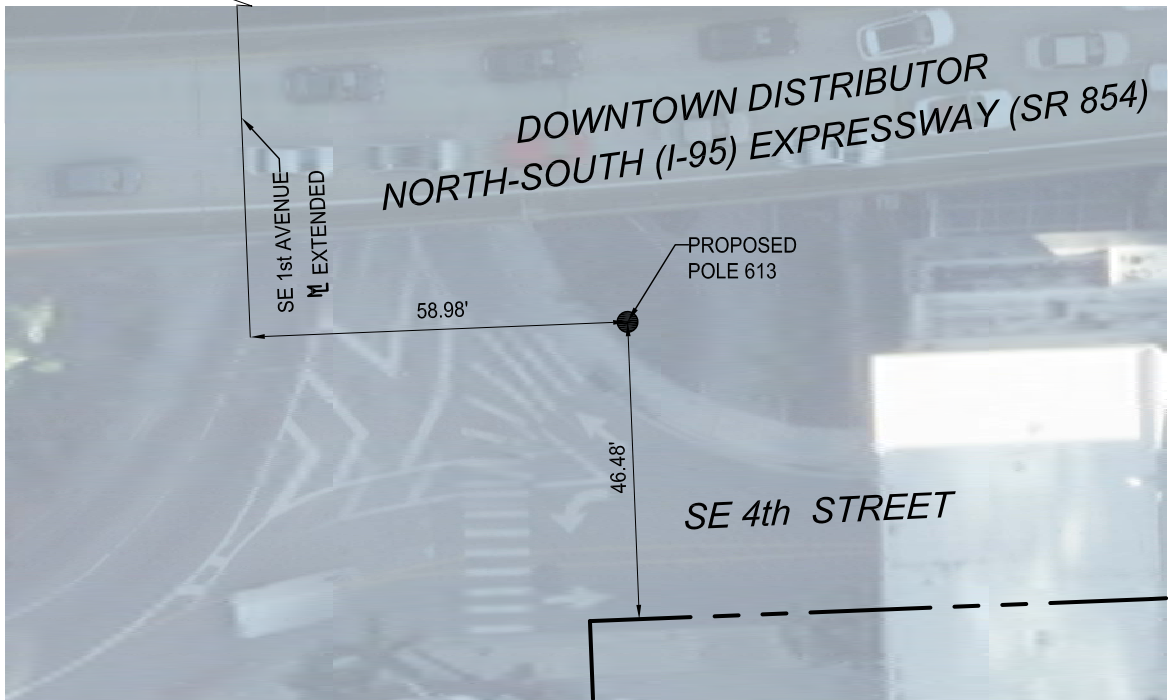
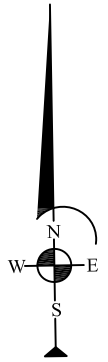
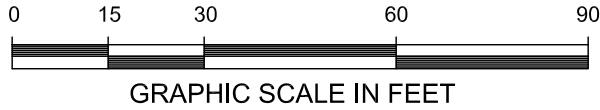

LEGEND:

- EXISTING RIGHT OF WAY LINE
- - - MAPPED (ZONED) STREET LINE
- ⊙ CENTER LINE
- M MONUMENT LINE

ABBREVIATIONS:

- SR - STATE ROAD
- R/W - RIGHT OF WAY

NOT A BOUNDARY SURVEY

MANUEL G.VERA AND ASSOCIATES, INC.
ENGINEERS-SURVEYORS & MAPPERS
 13960 S.W. 47th ST. MIAMI, FLORIDA 33175 L.B. No.2439
 PHONE: (305) 221-6210 e-mail: mverajr@mgvera.com

PROJECT NUMBER: 16-574		
TYPE OF PROJECT: SPECIFIC PURPOSE SURVEY		
PROJECT NAME: POLE LOCATION		
DATE: 08-3-2016	SCALE	SHEET
DRAWN BY: JCF	1"=30'	2 OF 2



LOCATION DESCRIPTION:

SE 1st Ave @ SE 4th St

FOR EXACT SIGN POST LOCATION
PLEASE REFER TO ATTACHED
SPECIFIC PURPOSE SURVEY SKETCH

Downtown Distributor
(I-95 SR-854)

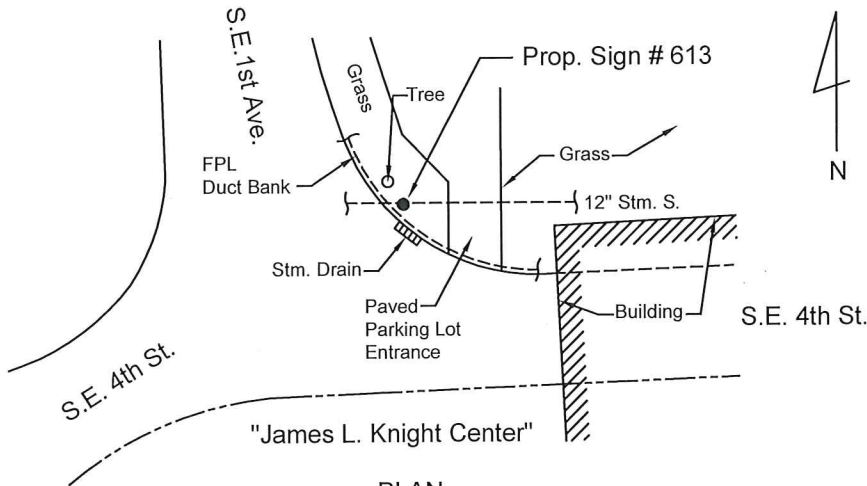

PLAN
NTS

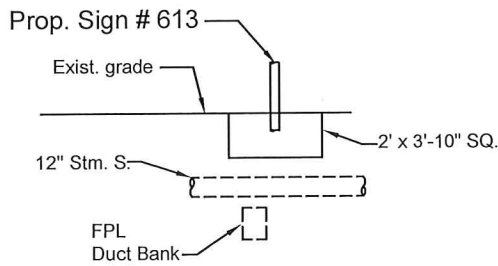

PROFILE
NTS

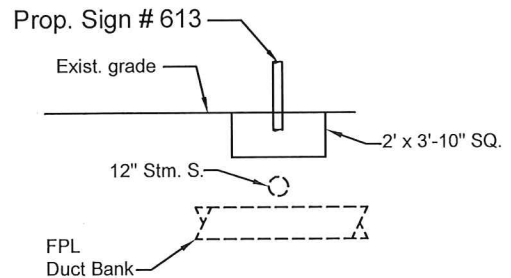

SECTION
(LOOKING EAST)
NTS

COMMENTS: Best Footer for Prop. Sign # 613 is: 2' x 3'-10" SQ.

MIAMI DDA - WAYFINDING AND SIGNAGE SYSTEM PROGRAM

DISCLAIMER:

This sketch has been prepared
for utility coordination purposes only.
This sketch is Not for Construction.

Utility coordination done by:
JRA Inc.
engineers-planners
10661 N Kendall Dr., Ste. 206B
Miami, FL 33176-1550
Phone 305-270-7800
CA 7613

CITY OF MIAMI

SIGN No. 613

Type Dist - ID.3

DATE: 03-28-2017

Sign No.
616



Downtown
Miami District
ID Program

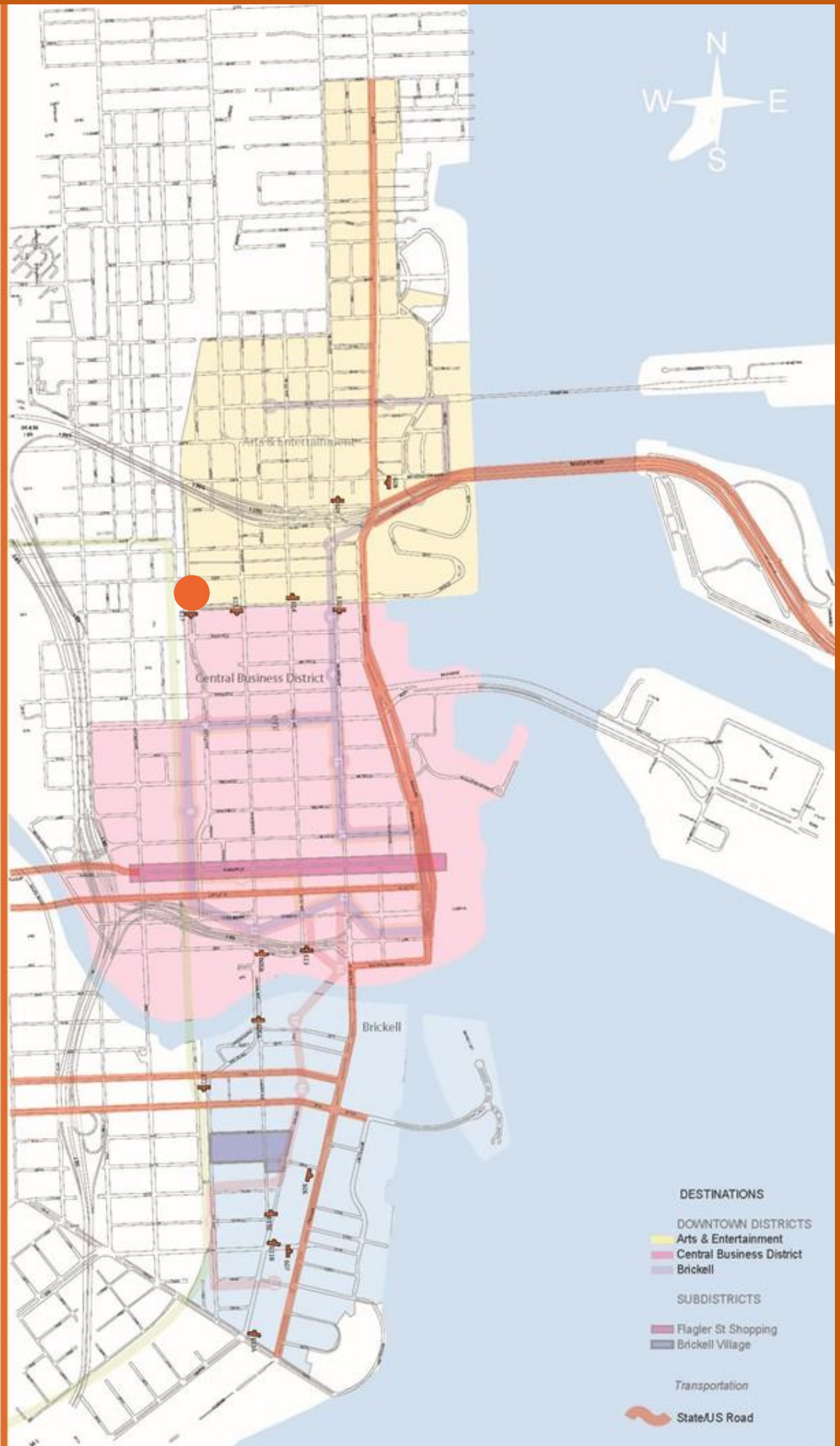

Wayfinding & Signage System Program

Downtown Miami, Florida

SIGN NO. 616

Location Aerial View:



Location Photo:

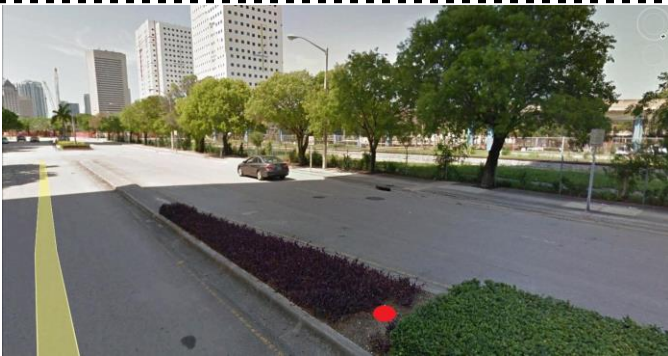

Reference Intersection: NW 1st Ave @ NW 9th St

Detailed Location: In planted median, where median becomes 8' wide

Orientation: NB

Right-of-Way Summary	Utilities Summary
City of Miami	Sanitary Sewer Unknown Pipe

Sign Type: DistID.3

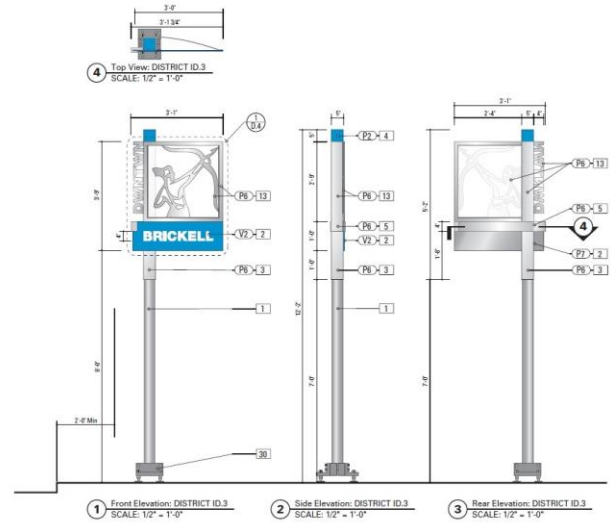

Sign Message:

Face A	Arts & Entertainment
Face B	None

Ground Condition: Grass

Foundation Type: 2' X 3' 10" Square

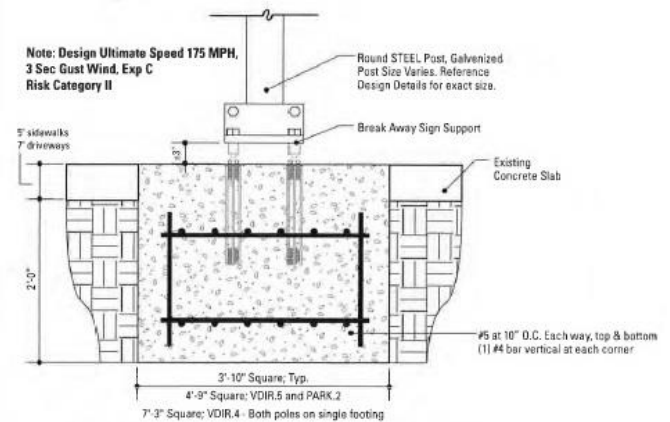

SPECIFIC PURPOSE SURVEY PROPOSED POLE 616

SURVEYOR'S REPORT :

- THE SPECIFIC PURPOSE OF THIS SURVEY IS TO SHOW THE LOCATION OF THE PROPOSED POLE IN RELATION TO THE MONUMENT LINES AND RIGHT-OF-WAY LINES.
- THIS IS NOT A BOUNDARY SURVEY
- THE LOCATION OF THE PROPOSED POLE SHOWN HEREON WAS PROVIDED BY THE CLIENT.
- THERE ARE EXISTING IMPROVEMENTS LYING WITHIN THE LIMITS OF THE SKETCH, WHICH ARE NOT SHOWN ON THIS SURVEY.
- REVIEW OF TITLE SEARCH WAS NOT PART OF THE SCOPE OF SERVICES.
- RIGHT-OF-WAY LINES AND MAPPED (ZONED) STREET LINES ARE AS PER CITY OF MIAMI ATLAS SHEET AND MIAMI-DADE COUNTY PLATS OF RECORD.
- POLE 616 LIES WITHIN THE JURISDICTION OF CITY OF MIAMI.
- INFORMATION REGARDING STREET JURISDICTION WAS TAKEN FROM MAP ENTITLED : DOWNTOWN MIAMI STREETS BY JURISDICTION PREPARED BY CITY OF MIAMI DATED SEPTEMBER 1, 2015 AND FURNISHED BY THE CLIENT.

SURVEYOR'S CERTIFICATION :

I HEREBY CERTIFY THAT THIS SPECIFIC PURPOSE SURVEY WAS PREPARED UNDER MY DIRECT SUPERVISION AND THAT IT IS TRUE AND CORRECT TO THE BEST OF MY KNOWLEDGE AND BELIEF AND I FURTHER CERTIFY THAT SAID SURVEY IS IN COMPLIANCE WITH THE STANDARDS OF PRACTICE AS SET FORTH BY THE FLORIDA BOARD OF LAND SURVEYORS AND MAPPERS IN CHAPTER 5J-17 FLORIDA ADMINISTRATIVE CODE PURSUANT TO SECTION 472.027 OF THE FLORIDA STATUTES.

 MANUEL G. VERA JR.
 PROFESSIONAL SURVEYOR AND MAPPER No. 5291
 STATE OF FLORIDA
 NOTICE: NOT VALID WITHOUT THE SIGNATURE AND ORIGINAL RAISED SEAL OF THE FLORIDA LICENSED SURVEYOR AND MAPPER.
 EACH SHEET AS INCORPORATED HEREIN SHALL NOT BE CONSIDERED FULL, VALID AND COMPLETE UNLESS ATTACHED TO THE OTHERS.

FOR SKETCH SEE SHEET 2

MANUEL G.VERA AND ASSOCIATES, INC.
 ENGINEERS-SURVEYORS & MAPPERS
 13960 S.W. 47th ST. MIAMI, FLORIDA 33175 L.B. No.2439
 PHONE: (305) 221-6210 e-mail: mvera jr@mgvera.com

PROJECT NUMBER: 16-574		
TYPE OF PROJECT: SPECIFIC PURPOSE SURVEY		
PROJECT NAME: POLE LOCATION		
DATE: 07-14-2016	SCALE	SHEET
DRAWN BY: JCF	N.A.	1 OF 2

NOT A BOUNDARY SURVEY

**SPECIFIC PURPOSE SURVEY
PROPOSED POLE 616**

0 15 30 60 90



GRAPHIC SCALE IN FEET

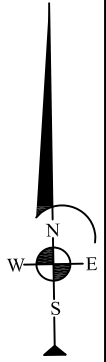

LEGEND:

- EXISTING RIGHT OF WAY LINE
- MAPPED (ZONED) STREET LINE
- CENTER LINE
- MONUMENT LINE

Z:\DESIGN 2016\16574_OF_City of Miami_Pole Locations\ACAD SKETCH\16 574 POLE 616.dwg

NOT A BOUNDARY SURVEY

MANUEL G.VERA AND ASSOCIATES, INC.
 ENGINEERS-SURVEYORS & MAPPERS
 13960 S.W. 47th ST. MIAMI, FLORIDA 33175 L.B. No.2439
 PHONE: (305) 221-6210 e-mail: mverajr@mgvera.com

PROJECT NUMBER: 16-574		
TYPE OF PROJECT: SPECIFIC PURPOSE SURVEY		
PROJECT NAME: POLE LOCATION		
DATE: 07-14-2016	SCALE	SHEET
DRAWN BY: JCF	1"=30'	2 OF 2

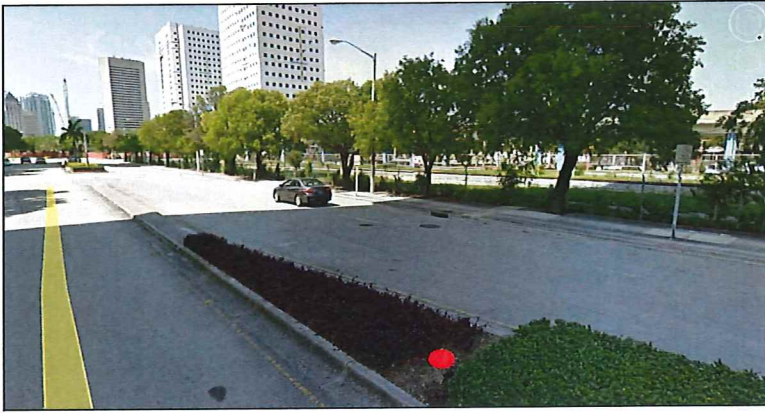

LOCATION DESCRIPTION:

NW 1st Ave S/O NW 10th St

FOR EXACT SIGN POST LOCATION
PLEASE REFER TO ATTACHED
SPECIFIC PURPOSE SURVEY SKETCH

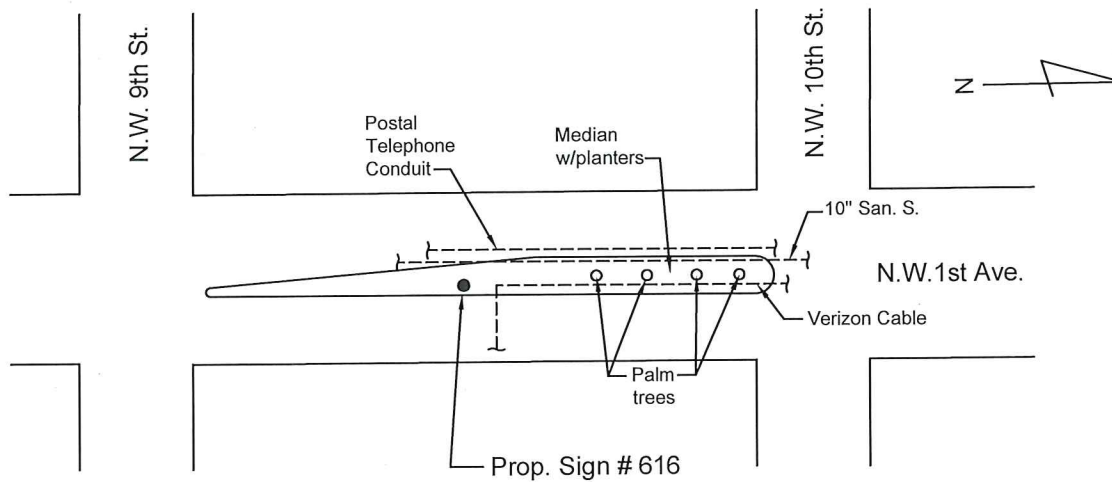

PLAN
NTS

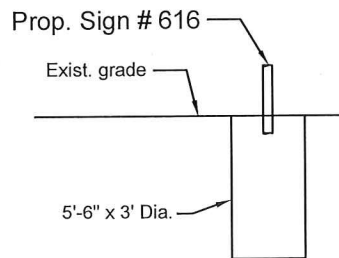

PROFILE
NTS

COMMENTS: Best Footer for Prop. Sign # 616 is: 5'-6" x 3' Dia.

MIAMI DDA - WAYFINDING AND SIGNAGE SYSTEM PROGRAM

DISCLAIMER:

This sketch has been prepared for utility coordination purposes only. This sketch is Not for Construction.

Utility coordination done by:
JRA Inc.
engineers-planners
10661 N Kendall Dr., Ste. 206B
Miami, FL 33176-1550
Phone 305-270-7800
CA 7613

CITY OF MIAMI

SIGN No. 616

Type Dist - ID.3

DATE: 03-28-2017

Sign No.
617



Downtown
Miami District
ID Program

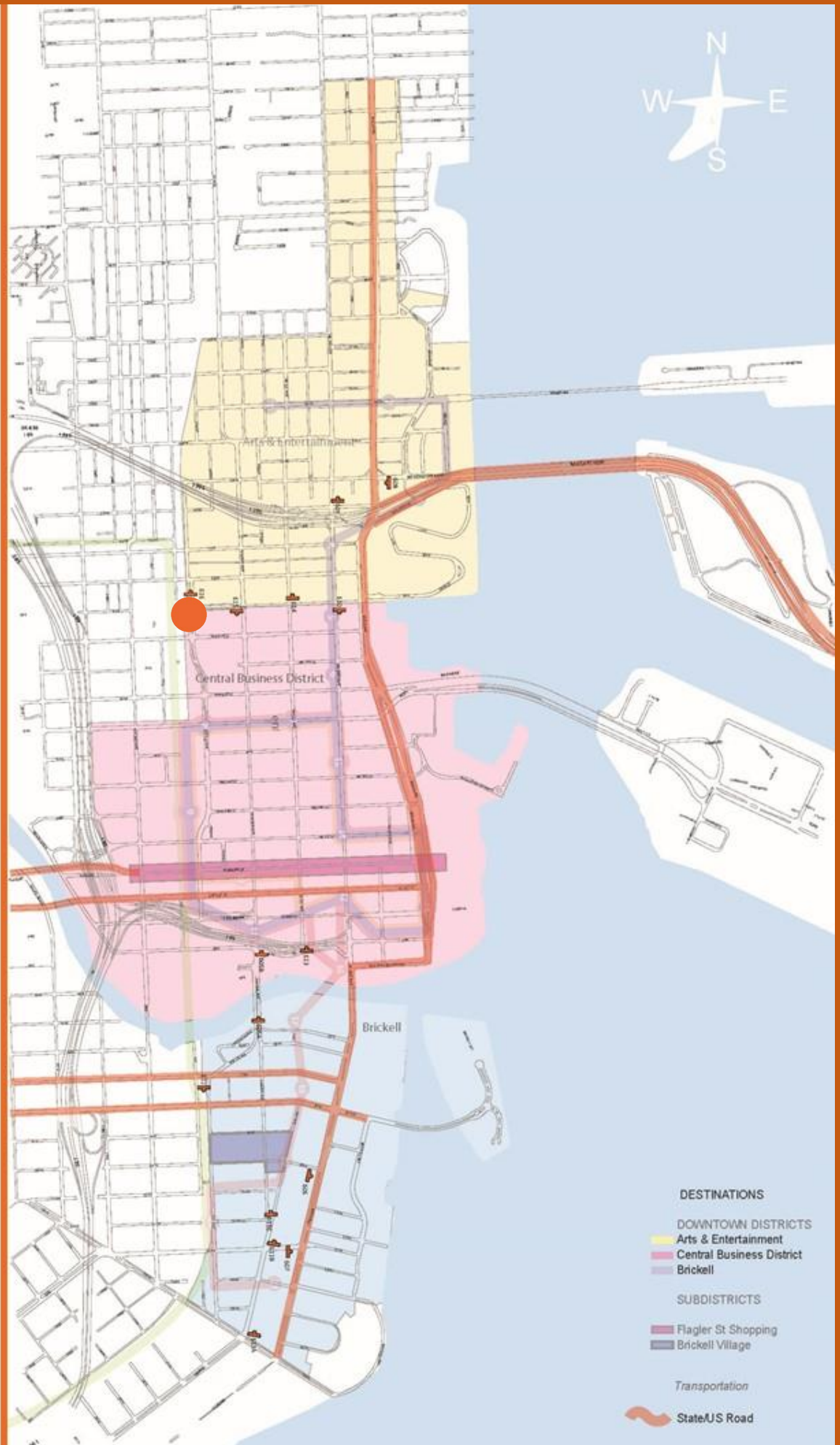

Wayfinding & Signage System Program

Downtown Miami, Florida

SIGN NO. 617

Location Aerial View:



Location Photo:



Reference Intersection: NW 1st Ave @ NW 9th St

Detailed Location: In planted median, 8' south of median's northern edge

Orientation: SB

Right-of-Way Summary	Utilities Summary
City of Miami	Sanitary Sewer

Sign Type: DistID.3

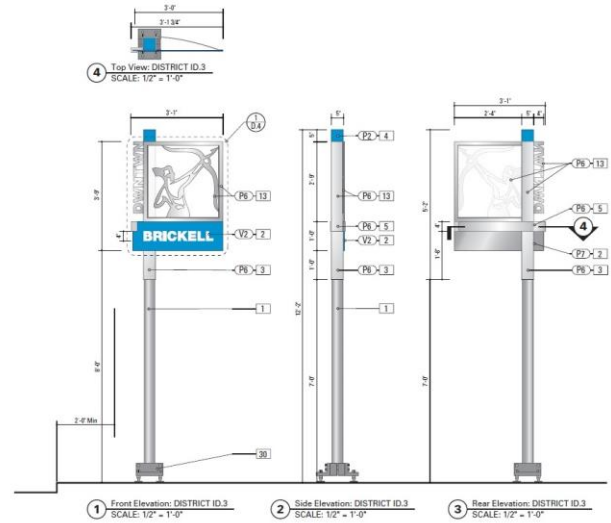

Sign Message:

Face A	Central Business District
Face B	None

Ground Condition: Grass

Foundation Type: 5' 6" X 3' Diameter

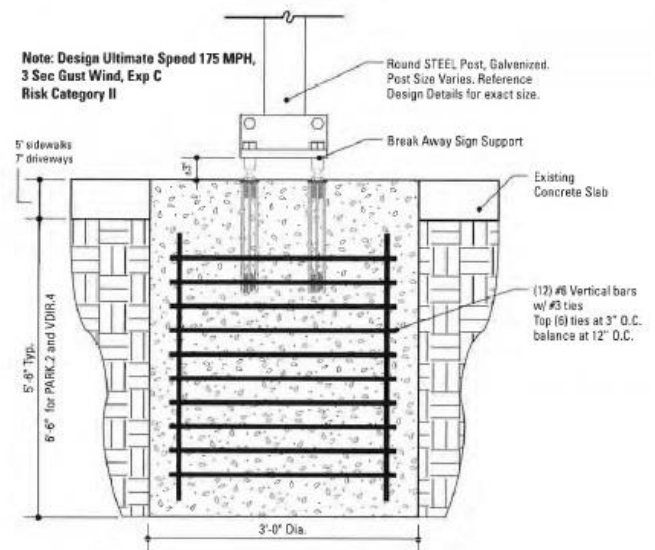

SPECIFIC PURPOSE SURVEY PROPOSED POLE 617

SURVEYOR'S REPORT :

- THE SPECIFIC PURPOSE OF THIS SURVEY IS TO SHOW THE LOCATION OF THE PROPOSED POLE IN RELATION TO THE MONUMENT LINES AND RIGHT-OF-WAY LINES.
- THIS IS NOT A BOUNDARY SURVEY
- THE LOCATION OF THE PROPOSED POLE SHOWN HEREON WAS PROVIDED BY THE CLIENT.
- THERE ARE EXISTING IMPROVEMENTS LYING WITHIN THE LIMITS OF THE SKETCH, WHICH ARE NOT SHOWN ON THIS SURVEY.
- REVIEW OF TITLE SEARCH WAS NOT PART OF THE SCOPE OF SERVICES.
- RIGHT-OF-WAY LINES AND MAPPED (ZONED) STREET LINES ARE AS PER CITY OF MIAMI ATLAS SHEET AND MIAMI-DADE COUNTY PLATS OF RECORD.
- POLE 617 LIES WITHIN THE JURISDICTION OF CITY OF MIAMI.
- INFORMATION REGARDING STREET JURISDICTION WAS TAKEN FROM MAP ENTITLED : DOWNTOWN MIAMI STREETS BY JURISDICTION PREPARED BY CITY OF MIAMI DATED SEPTEMBER 1, 2015 AND FURNISHED BY THE CLIENT.

SURVEYOR'S CERTIFICATION :

I HEREBY CERTIFY THAT THIS SPECIFIC PURPOSE SURVEY WAS PREPARED UNDER MY DIRECT SUPERVISION AND THAT IT IS TRUE AND CORRECT TO THE BEST OF MY KNOWLEDGE AND BELIEF AND I FURTHER CERTIFY THAT SAID SURVEY IS IN COMPLIANCE WITH THE STANDARDS OF PRACTICE AS SET FORTH BY THE FLORIDA BOARD OF LAND SURVEYORS AND MAPPERS IN CHAPTER 5J-17 FLORIDA ADMINISTRATIVE CODE PURSUANT TO SECTION 472.027 OF THE FLORIDA STATUTES.

 MANUEL G. VERA JR.
 PROFESSIONAL SURVEYOR AND MAPPER No. 5291
 STATE OF FLORIDA
 NOTICE: NOT VALID WITHOUT THE SIGNATURE AND ORIGINAL RAISED SEAL OF THE FLORIDA LICENSED SURVEYOR AND MAPPER.
 EACH SHEET AS INCORPORATED HEREIN SHALL NOT BE CONSIDERED FULL, VALID AND COMPLETE UNLESS ATTACHED TO THE OTHERS.

FOR SKETCH SEE SHEET 2

MANUEL G.VERA AND ASSOCIATES, INC.
 ENGINEERS-SURVEYORS & MAPPERS
 13960 S.W. 47th ST. MIAMI, FLORIDA 33175 L.B. No.2439
 PHONE: (305) 221-6210 e-mail: mverajr@mgvera.com

PROJECT NUMBER: 16-574		
TYPE OF PROJECT: SPECIFIC PURPOSE SURVEY		
PROJECT NAME: POLE LOCATION		
DATE: 07-14-2016	SCALE	SHEET
DRAWN BY: JCF	N.A.	1 OF 2

NOT A BOUNDARY SURVEY

**SPECIFIC PURPOSE SURVEY
PROPOSED POLE 617**

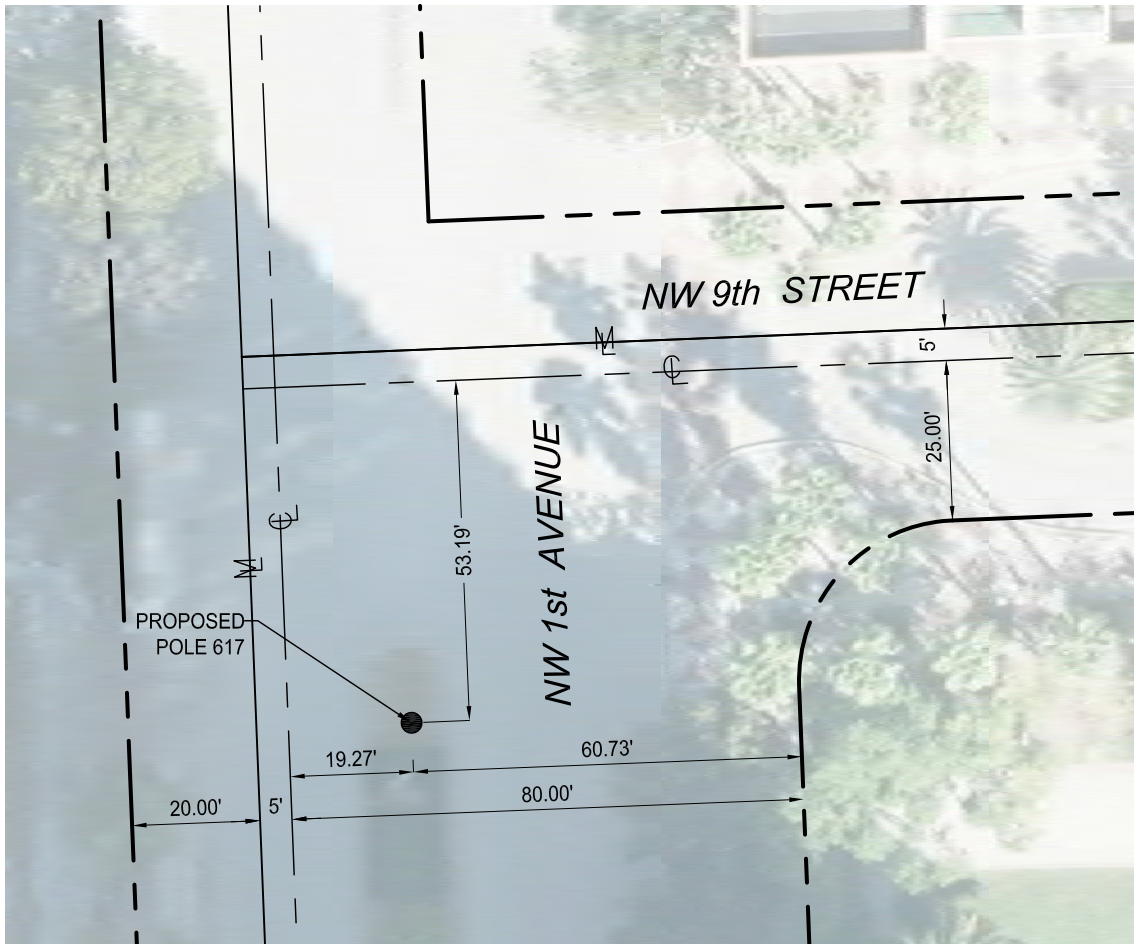
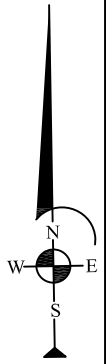
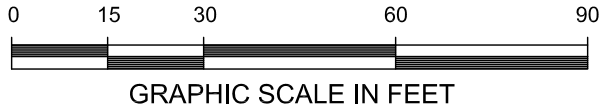

LEGEND:

- EXISTING RIGHT OF WAY LINE
- MAPPED (ZONED) STREET LINE
- CENTER LINE
- MONUMENT LINE

Z:\DESIGN 2016\16574_OF_City of Miami_Pole Locations\ACAD SKETCH\16 574 POLE 617.dwg

NOT A BOUNDARY SURVEY

MANUEL G.VERA AND ASSOCIATES, INC.
 ENGINEERS-SURVEYORS & MAPPERS
 13960 S.W. 47th ST. MIAMI, FLORIDA 33175 L.B. No.2439
 PHONE: (305) 221-6210 e-mail: mverajr@mgvera.com

PROJECT NUMBER: 16-574		
TYPE OF PROJECT: SPECIFIC PURPOSE SURVEY		
PROJECT NAME: POLE LOCATION		
DATE: 07-14-2016	SCALE	SHEET
DRAWN BY: JCF	1"=30'	2 OF 2



LOCATION DESCRIPTION:

NW 1st Ave S/O NW 9th St

FOR EXACT SIGN POST LOCATION
PLEASE REFER TO ATTACHED
SPECIFIC PURPOSE SURVEY SKETCH

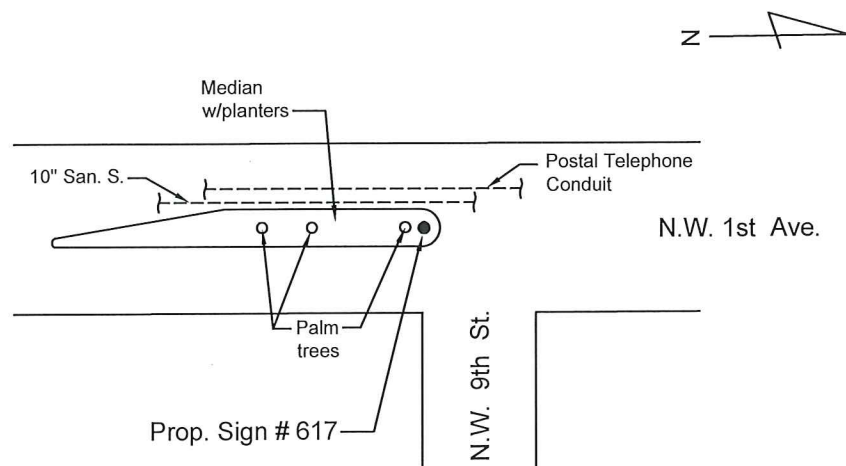

PLAN
NTS

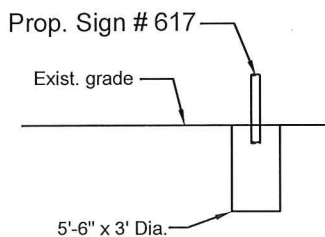

PROFILE
NTS

COMMENTS: Best Footer for Prop. Sign # 617 is: 5'-6" x 3' Dia.

MIAMI DDA - WAYFINDING AND SIGNAGE SYSTEM PROGRAM

DISCLAIMER:
This sketch has been prepared
for utility coordination purposes only.
This sketch is Not for Construction.

Utility coordination done by:
JRA Inc.
engineers-planners
10661 N Kendall Dr., Ste. 206B
Miami, FL 33176-1550
Phone 305-270-7800
CA 7613

CITY OF MIAMI

SIGN No. 617

Type Dist - ID.3

DATE: 03-28-2017