

## SECTION 03300

### CAST-IN-PLACE CONCRETE, REINFORCING AND FORMWORK

#### PART 1 GENERAL

##### 1.01 DESCRIPTION

- A. Work included: Provide all labor, materials, equipment, fabrication, incidentals, transportation, placing and supervision necessary to complete all cast-in-place concrete work, its finishing, and all related work called for by the Plans and/or Specifications, or reasonably inferable from either or both, as needed for a complete and proper installation.
- B. Related work: Work affecting this Section includes, but is not limited to:
  - 1. Shop Drawings - Per General Conditions and as specified herein.
  - 2. Materials and storage thereof.
  - 3. Reinforcing-Bar and fabric.
  - 4. Accessories of every nature, including form tie system.
  - 5. Formwork and removal thereof, including shoring and reshoring.
  - 6. Concrete proportions and mixes.
  - 7. Placing of concrete.
  - 8. Admixtures.
  - 9. Joints, metal joint screeds and joint fillers.
  - 10. Finishes of all types.
  - 11. Protection and curing.
  - 12. Patching.
  - 13. Laboratory Testing.

##### 1.02 QUALITY ASSURANCE

- A. Unless otherwise indicated, all materials, workmanship and practices shall conform to the requirements of ACI 301-96 "Specifications for Structural Concrete for Buildings", except as modified by supplemental requirements hereinafter.

##### 1.03 STANDARDS

- A. ACI 301-10 Specifications for Structural Concrete.
- B. ACI 318-11 Building Code Requirements for Reinforced Concrete.
- C. Florida Building Code, latest edition.
- D. ACI 117-10 Standard Specifications for Tolerances for Concrete Construction and Materials.

## PART 2 PRODUCTS

### 2.01 MATERIALS

#### A. Materials for Concrete:

1. Cement shall conform to the following: Portland Cement ASTM C150, normal, type I or type II. Provide domestic cement of one type and from same source for entire project.
2. Mineral Admixtures:
  - a. Fly Ash: Shall conform to ASTM C618. 20% maximum of total cementitious weight.
  - b. Ground Blast Furnace Slag: Shall conform to ASTM C989-93. 30% maximum of total cementitious weight.
3. Chemical Admixtures: The following admixtures are permitted, but require written approval from the Engineer:
  - a. Air Entraining Admixture: Comply with ASTM C260. "Specifications for Air-Entraining Admixtures for Concrete."
  - b. Water Reducing Admixture: Comply with ASTM C494 "Specifications for Chemical Admixtures for Concrete", Type A and compatible with air entraining admixture.
  - c. Water Reducing and Retarding Admixture: Comply with ASTM C494, "Specifications for Chemical Admixtures for Concrete", Type D, and compatible with air entraining admixture.
  - d. High Range Water Reducing Admixture: Comply with ASTM C494, "Specifications for Chemical Admixtures for Concrete", Type F or G, and compatible with air entraining admixture. (Including superplasticizer to reduce water content.)
  - e. Admixtures containing added calcium chloride are not permitted.
4. Aggregates: Shall conform to ASTM C33 and shall be quarried/mined in fresh water. Aggregates from salt water or brackish water are not permitted.
  - a. Fine aggregate shall be silica (quartz) sand. Manufactured sand and screenings are not permitted.
  - b. Coarse aggregate size shall not exceed:

<u>Concrete Member</u>		<u>Size</u>	
1)	Walls	3/4"	67#
2)	Beams or structural slabs not on ground	3/4"	67#
3)	Columns and all other concrete	1"	57#
4)	Drilling concrete pad or slabs on ground	1"	57#

5. In sanitary sewage applications, where called for in the Plans and/or specifications an antimicrobial admixture as specified below shall be utilized:
  - a. An antimicrobial agent, Con<sup>MIC</sup>Shield<sup>®</sup>, or approved equal, shall be used to render the concrete uninhabitable for bacteria growth.
  - b. Contractor shall mix the liquid antimicrobial additive with the

total water content of the concrete mix design in a proportion of 1 gallon per cubic yard. In the case of repairs to damaged concrete a proportion of 2 gallons per cubic yard shall be utilized.

- c. In some instances all of the concrete in the structure in will receive the additive and in other instances only a portion of the concrete will receive the additive. Hence, the Contractor shall apply the additive only as directed in the specific instance.
  - d. Contractor shall submit a letter of certification to the Department, stating that the correct amount and correct mixing procedure was followed for all antimicrobial concrete.
  - e. Con<sup>MIC</sup>Shield<sup>®</sup> antimicrobial additive shall be as manufactured by Con<sup>MIC</sup>Shield<sup>®</sup> Technologies, Inc.; 541 Tenth Street NW #233, Atlanta, GA 30318; Phone: 877-543-2094.
- B. Portland cement and reinforcing steel: Comply with ACI 301-10 and, with all modifications and supplements thereto listed in Part 3 of these Specifications.
- C. Burlap mats: Conform to AASHTO Specification M182. (Burleen non-staining mats.)
- D. Epoxy bonding agent: A two (2) component, solvent free, moisture insensitive structural epoxy adhesive conforming to ASTM C881-13 Type II, Sikadur 32 Hi-Mod, as manufactured by Sika Corp., Conpressive 1090 Liquid by Master Builders or approved equal.
- E. Anchor bolts, nuts and washers: Conform to ASTM A449-10, hot-dip galvanized.
- F. Dovetail slots: Galvanized steel, 22 gauge, 1 x 1 inch, with 5/8-inch throat, fiber filled.
- G. Forms:
- 1. Plywood Forms: PS-1, B-B Concrete Form, Class I, exterior type, mill oiled and edge sealed. Thickness shall be as required to support concrete at the rate placed, but not less than 3/4-inch.
  - 2. Steel Forms: Uncoated steel, 3/16-inch minimum thickness, fabricated to close tolerances, protected only by the specified release agent, braced so as not to dent, bend or dimple under wet concrete loads, vibrator impact and tool impact. Maintain steel forms in rust free condition by use of steel wool and light grinding, followed by coats of the specified release agent. Forms should be adjustable to be brought into true alignment without steps or ridges.
- H. Form release agent:
- 1. For plywood forms use a natural non-petroleum base, non-staining and non-retarding release agent that will effectively prevent absorption of moisture and prevent bond with concrete, and leaves the concrete with a

- paintable surface.
2. For steel forms, use an approved material that will not stain, color or otherwise affect the finish of the concrete. Form coating shall not be detectable on finished surfaces.
  3. Round column forms: Provide seamless fiber forms with the three plies nearest to the interior surface of the form deckled or scarfed and overlapped to minimize spiral gaps or seams on the column surface.
- I. Form Ties: Steel rod type with integral waterstops and cones, and with ends or end fasteners that can be removed without spalling the concrete and which leave a hole equal in depth to the required reinforcement clearance, but not less than 2 inches from the formed face of the concrete. Wire tie, banding wire and wood spreaders will not be permitted.
- J. Form Inserts:
1. Bevel or chamfer strips: Wood or non-staining plastic, 3/4-inch wide on each leg at exposed edges of concrete members, unless otherwise noted on plans.
  2. Tongue and Groove Joint Forms: Minimum 24 gauge with steel stakes and splice plates. Forms shall be designed for joints not to receive a poured seal.
  3. Pipe hangers and other utility supports: AISI Type 316 stainless steel.
- K. Non-Shrink Grout: Non-shrink, non-metallic grout conforming to ASTM C1107-13 Grade B or Grade C only. Grout must meet ASTM C1107-13 at a temperature range of 50°F to 90°F at a flowable consistency.
- L. Grout for Surface Repair and Bond Coat:
1. For repair, one part Portland cement to two parts fine sand, and a 50% of water and 50% Acryl 60 or equal (Thoroseal or Acryl Set Bonding Agent by Master Builders) to produce a stiff mortar.
  2. For bond coat, one part Portland cement to one part sand, and a 50% of water and 50% Acryl 60 or equal (Thoroseal or Acryl Set Bonding Agent) to produce a slurry mix.
- M. Moisture Barrier: Kraft paper and glass reinforcing fibers sandwiched between 2 layers of polyethylene film with a permeance rating of maximum 0.1 as per ASTM E96-00, Procedure A.
- N. Preformed Expansion Joint Filler: Non-extruding type, self expanding cork, 3/4-inch, 1-inch, and 1-1/2-inch cork (not to be used for sidewalks), conforming to plans or as otherwise noted on drawings, conforming to the requirements of ASTM D1752-04a (2013), Type II, and compatible with joint sealant compound.
- O. Joint Sealant Compound: Non-sag, 2 component, solvent free, moisture insensitive, flexible, epoxy resin conforming to the requirements ASTM C920-14 Type M, Grade NS. Additionally, the sealant must be recommended by the manufacturer to perform under continuous immersion in water.
- P. Polyurethane Elastomeric Sealant: Sikaflex-2c, NS/SL or approved equal. Provide a 2-component, premium-grade, polyurethane-based, elastomeric

sealant. It is principally a chemical cure in a non-sag and self-leveling consistency. Sealant shall meet ASTM C920-14 and Federal Specifications TT-S-00227E.

1. Joint Movement: +50%.

Q. Waterstops:

1. Volclay Waterstop-RX or approved equal. Flexible strip of bentonite waterproofing compound in coiled form.
  - a. Chemical Composition:
    - 1) Butyl Rubber-Hydrocarbon: 24.9% by weight; ASTM D297.
    - 2) Bentonite: 75% by weight; SS-S-210-A.
    - 3) Volatile Matter: Below 1%; ASTM D6.
    - 4) Waterstop shall not contain any asbestos fibers or asphaltics.
  - b. Physical Properties:
    - 1) Specific Gravity: 1.57; ASTM D71.
    - 2) Application Temperature Range: 5-125°F.
    - 3) Flash Point: 365; ASTM D93-97.
    - 4) Accelerated Aging: Maintained 99% solids.
    - 5) Dimensions: 1" x 3/4" x 16'-6"
2. Polyvinyl chloride (PVC): Conforming to the requirements of U.S. Army Corps of Engineers Specification CRD-C-572 and of the following type:
  - a. Expansion Joints: 9-inches by 3/8-inch, ribbed center bulb.
  - b. Construction Joint: 9-inches by 3/8-inch, flat ribbed.
  - c. Only where specified on Plans at construction and expansion joints: 9-inches by 3/8-inch, split ribbed.
  - d. Install waterstops as shown as manufactured structures.

R. Fiber Reinforcement: Fiber reinforcement shall not be used in the concrete unless ordered by the Engineer in writing. It shall consist of 100% virgin polypropylene fibrillated fiber-dosage of 2 lbs. per cubic foot.

1. Compressive Strength: 1 psi (.006895 M Pa), ASTM C39.
2. Flexural Strength: 288 psi (2.0 M Pa) after 7 days, 390 psi (2.7 M Pa) after 28 days; ASTM C78.
3. Splitting Tensile Strength: 194 psi (1.3 M Pa) after 7 days, and 290 psi (2.0 M Pa) after 28 days; ASTM C496.
4. Source: Fibermesh Micro-Reinforcement System by Fibermesh Company, Division of Synthetic Industries, Inc., or approved equal.

S. Provide other materials, not specifically described but required for a complete and proper installation, as selected by the Contractor subject to the approval of the Engineer.

T. A shrinkage reducing admixture (Teraguard) or equivalent at the rate of 2.2% by weight of cement may be used in the concrete to meet the shrinkage limitations.

U. To protect the concrete slab against the elements, the Engineer may direct the Contractor to spray an evaporation retarder on the finished concrete slab

immediately behind the cement finishing process at no additional cost to the Department. This is not a curing compound.

## **PART 3 EXECUTION**

### **3.01 SURFACE CONDITIONS**

- A. Examine the areas and conditions under which work of this Section will be performed. Correct conditions detrimental to timely and proper completion of the Work.

### **3.02 SUPPLEMENTAL REQUIREMENTS**

- A. All phases of concrete construction, including materials formwork, and all other related procedures shall comply with the most stringent allowed tolerances of ACI-301 and ACI-117 Standards (Latest Edition) - Non compliance with these standards will cause full rejection of any work done.
- B. Comply with ACI 301-10 and with all modifications and supplements thereto listed herein. In addition to the ACI Standards on finished concrete, the Engineer will only approve quality finished concrete which in his opinion is ready to receive a grout finish, paint or liquid membrane.
- C. The following modifications and supplements to ACI 301-10 shall also apply to the work.
  - 1. General
    - a. These specifications cover cast-in-place structural concrete for use in buildings and appurtenances, including foundations, curbs, sidewalks, concrete pavements and utility structures, water containment tanks, and piles.
    - b. Keep minimum two (2) copies of ACI 301-10 "Specifications for Structural Concrete" in field office at all times.
  - 2. Proportioning and Design of Mixes:
    - a. General: Proportion concrete to meet properties as specified. Prepare mix designs for each type and strength of concrete. Submit with mix design the chemical admixture manufacturer's statement that the admixture proposed complies with the requirements of this specification. Where concrete of different strengths are specified for the same location, the higher strength concrete shall be used. Concrete proportions shall be established on the basis of previous field experience, or laboratory trial batches as specified in ACI 301-10 Sections 4.2.2 & 4.2.3.
    - b. Classes of Concrete:
      - 1) Structural concrete of normal weight for portions of the structure that are required to be watertight containments or tremie concrete, the water/cementitious ratio shall not exceed 0.45 if exposure is to be to fresh water.
      - 2) If the concrete is exposed to salt or brackish water, or if exposed to injurious concentrations of sulfate-containing

solutions (1,500 ppm or more of Sulfate in water) or other chemically aggressive solutions, use Type II cement with Rheobuild 1000 admixture by Master Builders, or approved equal; water/cementitious ratio shall not exceed 0.34.

- 3) Other Concrete: (This would be slabs-on-grade, concrete thrust blocks, and miscellaneous concrete). The water cementitious ratio shall not exceed 0.50 to 0.55.
- 4) Minimum f'c @ 28 days shall be 3,000 psi.
- 5) Minimum f'c @ 28 days shall be 4,000 psi with a Water/Cement ratio of 0.45. (see 1) above)
- 6) Minimum f'c @ 28 days shall be 7,000 psi with a Water/Cement ratio of 0.34. (see 2) above)

c. Slumps:

- 1) All structural concrete, pumped concrete and tremie concrete shall contain a High Range Water Reducing Admixture and be designed with a maximum water content of 270 pounds per cubic yard (32.36 gallons). The initial water slump prior to addition of the High Range Water Reducing Admixture shall be 2 inches maximum. Concrete at point of placement shall not exceed 10 inches. Concrete shall be non-segregating.
- 2) Slabs including slabs-on-grade, and all other concrete shall have a maximum water content of 287 pounds per cubic yard (34.4 gallons) and have a 5-inch maximum slump with a water reducer, or water reducer and retarder admixture added.

3. Formwork

- a. Earth cuts are not permitted for forms for vertical surfaces. Footings, grade beams and slab edges shall be formed. Provide moisture barrier under all slabs on grade. Lap 6 inches and tape punctures.
- b. The contractor is responsible for the adequacy of forms and shoring including placing, fill and equipment on roof, and for safe practice in their use and removal. Submit formwork calculations, and shop drawings including shoring and reshoring. In addition, the calculations and shop drawings for formwork, shoring, and reshoring, if required by the Engineer or Building Department, shall be signed and sealed by a Professional Engineer registered in the State of Florida.
- c. Design forms for the loads and lateral pressures resulting from the placement and vibration of concrete and for design considerations, wind loads, allowable stresses, and other applicable requirements of the Florida Building Code.
- d. Provide form facing materials as required by the specified finish of the formed surface. Do not use facing material with raised grain, torn surfaces, worn edges, patches, dents or other defects. No form may be reused more than three times without the Department's approval. The maximum deflection permitted of facing materials reflected in concrete surfaces exposed to view is

1/240 of the span between structural members.

- 1) Forms shall be free from surface defects, tight to prevent leakage and braced to keep its position and shape when filled with concrete. Adjacent edges and end panels and sections shall be held together to provide accurate alignment and prevent forming ridges, fins, offsets or similar type defects in finished concrete. It shall be tight to prevent loss of water, cement or fines during placing and vibrating concrete. The bottom of the forms placed in continuous straight even footings or slabs shall be watertight to prevent loss of water, cement and fines during placement and vibration of concrete, a gasket may be required by the Engineer under the forms to provide water tightness at the Contractor expense. The Contractor shall not proceed to place forms for concrete work adjacent to or on top of previous placed concrete without the Engineer's approval, if the stripped forms reveals columns, walls or beams are out of level or plumb or there are cold joints or other objectionable work in the opinion of the Engineer. Contractor shall submit to the Engineer for approval, how he intends to correct or remove the defective work promptly at his expense. Contractor shall perform such corrections prior to proceeding to place concrete in the next Section.
- 
- e. Provide positive means of adjustment (wedges or jacks) of shores and struts, and all settlement shall be taken up during concrete placing operation. Brace forms securely against lateral deflection. Do not anchor form bracing to poured concrete floors, or make holes in floor.
  - f. Provide temporary openings in columns and wall forms to limit the free fall of concrete to five (5) feet. Place such openings at no more than eight (8) feet apart to facilitate placing and consolidation of concrete. Elephant trunks may be used to vertical heights of fifteen (15) feet for tremie and other purposes, if approved by the Engineer. Provide temporary openings at the bottom of wall and column forms and elsewhere as necessary to facilitate cleaning and observation immediately before concrete is placed. Blow formwork entirely clean of all saw dust, dirt, or other items not specifically intended to be a part of the final concrete. Any evidence of non-intended items in the forms is considered sufficient cause to stop concreting operation and/or require removal of concrete placed in such contaminated forms.
  - g. Provide inserts, conduits, boxes, sleeves, anchors, ties, bolts, hangers, dowels, thimbles, nailers, grounds and other devices in coordination with other trades.
  - h. Set anchor bolts and other embedded items accurately and hold securely until concrete is placed and set. Anchor bolts shall be galvanized and of size and length as indicated on the Plans. Bolts not sized shall be 3/4-inch diameter.
  - i. Insert galvanized dovetail anchor slot in forms, in columns, beams



and slabs completely around in-fill masonry panels. Coordinate with Section 04220 Unit Masonry for spacing of dovetails.

- j. Install wall spools, wall flanges and wall anchors before placing concrete. Do not weld, tie or otherwise connect the wall spools to the reinforcing steel.
- k. Do not use pinch bars, wrecking bars or other metal tools against as-cast concrete to wedge forms loose; use only wooden wedges carefully and gradually. Driving shall be accomplished by light tapping.
- l. The Contractor is responsible for the removal of forms and shores. Concrete shall be cured in accordance with ACI 308r-01 (also see section 10 below). Do not remove forms or shores before the member has attained sufficient strength to support its weight and the loads imposed, nor sooner than listed below:
  - 1) Wall forms: 24 hours.
  - 2) Column forms: 24 hours.
  - 3) Beam and girder side forms only (not bottom form): 24 hours.
  - 4) Beam and Girder bottom forms: 7 days minimum unless otherwise approved by the Engineer.
  - 5) Slab forms: 14 days.
  - 6) Arch centers: 7 days.
  - 7) Pan joist forms: 4 days.

4. Reinforcement

- a. Prior to fabrication, submit for review shop drawings showing all fabrication dimensions, bar lists and location for placing of the reinforcing steel and accessories, including spacing of reinforcing, splices (lap, welded, Cadweld and/or mechanically threaded), grade of reinforcing and name of manufacturer. Note all deviations from the Plans and use the same designation mark as shown on the Plans where possible.
- b. Reinforcing bars: ASTM A615, Grade 60, deformed bars of USA manufacturer.
- c. Welded wire fabric: ASTM A185, galvanized.
- d. Metal bar supports: CRSI MSP-1, Chapter 3, Class 2, Type B stainless steel protected bar supports.
- e. Coupler Splice Devices: Cadweld, tension couplers capable of developing the ultimate strength of the bar.
- f. Reinforcing steel upon which unauthorized welding has been done, shall be removed and replaced at no additional cost to the Department.
- g. Place reinforcing bars to the most stringent tolerances indicated in ACI 301 and ACI 117 (Latest Edition). Tolerances specified in those standards shall govern over any other reference code or standard.
- h. All reinforcement at time concrete is placed shall be free of mud, oil or other materials that may affect or reduce the bond. Reinforcing with rust or mill scale will not be accepted without cleaning and/or brushing to remove scale and rust.
- i. Support rebar and mesh reinforcing for slabs on grade 1-1/2

- inches from top of slab on masonry blocks not less than 4 sq. in., having a compressive strength equal to or greater than the specified strength of the concrete being placed. Space blocks at no more than 4 feet apart each way for rebars, and no more than 3 feet apart for mesh reinforcement.
- j. Support reinforcing off from formwork for columns, walls and beams with stainless steel protected bar supports. Support slab reinforcing on #5 bars, or larger, spaced at no more than 48 inches on center. Space individual high chairs no more than 48 inches apart and support bars shall not exceed 24 inches past outermost chairs.
  - k. Overlap welded wire fabric in such a manner that the overlap measured between outermost cross wires of each fabric sheet is not less than the spacing of the cross wires plus 2 inches or 6 inches, whichever is greater. Do not extend fabric through expansion and/or contraction joints, unless otherwise noted on the Plans.
  - l. The minimum clear distance between parallel bars, both vertical and horizontally, shall not be less than the nominal diameter of the bars, or less than 1-1/2 times the maximum size of the aggregate, or 1 inch in beams, or 1-1/2 inches in columns, whichever is greater. Where reinforcement in beams is placed in two or more layers, the upper layer shall be placed directly above the bars in the bottom layer. Misplacement, misalignment or improper length of dowels shall be sufficient cause to require removal and reconstruction of affected work.
  - m. Unless allowed by the Engineer, bending of reinforcing partially embedded in concrete is not permitted. When permitted, bending shall be in accordance with CRSI Manual of Standard Practice.
5. Joints and Embedded Items.
- a. Provide premolded expansion joint filler strips of proper width and length as specified in the Plans. Place 1/2-inch expansion joint fillers every 20 feet in straight runs of walkways or sidewalks, at right angle turns and wherever concrete butts into vertical surfaces, unless otherwise noted on the Plans.
  - b. Provide waterstops in all construction joints, unless otherwise indicated on the Plans.
  - c. Join all waterstops at all intersections so that a continuous seal is provided. Center the waterstop in the joint. Hold water stop positively in correct position. In the event of damage to the waterstop, repair the water stop in an acceptable manner. Vibrate concrete to obtain impervious concrete in the vicinity of all joints.
  - d. Install waterstop in accordance with instructions of the manufacturer. Prior to use of the waterstop material in the field, submit to the Engineer for approval a sample of each size and shape to be used. Fabricate sample so that the material and workmanship represent in all respects the fittings to be furnished under this Specification.
  - e. Place all sleeves, inserts, anchors, and other embedded items prior to placing concrete. Anchors and bolts cast in concrete shall

be hot dip galvanized or stainless steel. Where permitted by the Engineer, concrete expansion bolts shall be stainless steel and of the wedge anchor type. Take all necessary precautions to prevent embedded items from being displaced, broken or deformed during concreting operation. Protect drains from intrusion of concrete.

6. Placing:

- a. Equipment for mixing and transporting concrete must be clean. Forms shall be thoroughly clean and damp, and reinforcing shall be secured in place. Runways for transporting concrete shall not rest on reinforcing. When concrete is placed against earth, sprinkle sufficiently before placing.
- b. Deposit of concrete in forms no longer than ninety (90) minutes after the initial design water has been added to the cement and aggregates. Concrete which can not be so placed shall not be used and shall be wasted. **No additional water shall be added.** No rettempering with water is permitted.
- c. In addition to the requirements of ASTM C94, the concrete delivery tickets shall indicate the cement content and water/cement ratio.
- d. During hot weather, proper attention shall be given to ingredients, production methods, handling, placing, protection and curing. Comply with ACI 305R "Hot Weather Concreting" recommendations.
- e. Do not place concrete in forms unless the water level is below the concrete to be placed, even if it is necessary to maintain the dewatering, or under rain.
- f. Do not place concrete under water except for tremie concrete as called for on the Plans. Submit for approval plan and details of means and methods for installation of seal tremie concrete prior to commencement of work. Seal concrete which subsequently fails to perform, shall be repaired or replaced at no additional cost to the Department.
- g. Place seal concrete under water in the space in which it is to remain, by means of a tremie, a closed-bottom dump bucket of not less than one cubic yard capacity, or other approved method, and do not disturb after it is deposited. Deposit all seal concrete in one continuous pour. Do not place concrete in running water. Design all formwork, to retain concrete under water, to be watertight. Submit shop drawings for the design of formwork and excavation sheeting signed and sealed by a Florida Registered Professional Engineer.
- h. The tremie shall consist of a tube having a minimum inside diameter of ten (10) inches, and shall be constructed of sections having tight joints. No aluminum parts which have contact with the concrete will be permitted. The discharge end shall be entirely seated at all times and the tremie tube kept full to the bottom of the hopper. When a batch is dumped into the hopper, the tremie shall be slightly raised (but not out of the concrete at the bottom) until the batch discharges to the bottom of the hopper, after which

the flow shall be stopped by lowering the tremie. The means of supporting the tremie shall be such as to permit the free movement of the discharge end over the entire top surface of the work, and shall permit it being lowered rapidly when necessary to choke off or retard the flow. The flow shall preferably be continuous and in no case shall be interrupted until the work is completed. Exercise special care to maintain still water at the point of deposit.

- i. When the concrete is placed by means of a bottom dump bucket, the bucket shall be lowered gradually and carefully until it rests upon the concrete already placed. The bucket shall then be raised very slowly during the discharge travel; the intent being to maintain, as nearly as possible, still water at the point of discharge and to avoid agitating the mixture. Aluminum buckets will not be permitted.
- j. Do not commence pumping, to dewater a sealed cofferdam, until the seal has set sufficiently to withstand the hydrostatic pressure, and in no case earlier than 72 hours after placement of concrete.
- k. Notify Engineer a minimum of 24 hours prior to concreting and request a specific time for observation of reinforcing and formwork for portions of concrete work to be placed. No observation will be made by the Engineer until rebar installation for all work to be done and all formwork has been completed and approved by the Contractor's field superintendent. Do not order concrete until all correction and additions indicated by the Engineer have been made. Should the Engineer's observation reveal that work is improperly prepared and an additional observation will be required, he will so inform the Contractor and all above requirements shall also govern.

7. Repair of Surface Defects:

- a. Repair all concrete surface defects, which includes, but not limited to cracks, tie holes (no plastic cones), uneven holes, honey combs, rough frame work and other objectionable conditions deemed unacceptable to the Engineer immediately after form removal. This repair work is to be done for all concrete expose surfaces, liquid applied surface or painted surfaces in or out of the water. Repair all cracks and defects in the concrete floors, beams, joists, columns, and other structural members, roof and walls, to the satisfaction of the Engineer, that may occur up to one year after acceptance of work regardless of the cause. Test unformed, surfaces such as monolithic slabs, for smoothness and verify placement tolerances specified for each surface and finish. Test unformed surfaces sloped to drain for trueness of slope, in addition to smoothness. Repair unformed surfaces that contain surface defects which affect durability of concrete. Surface defects, as such, include cracking, cracks which penetrate to reinforcement or completely through non-reinforced sections regardless of width, spalling, pop-outs, honeycomb, rock pockets and other objectionable and rough conditions.

- b. Proprietary compounds for adhesion or as patching ingredients may be used, if approved by the Engineer. All structural repair of surface defects to be made require the approval of the Engineer, as to the method and procedure. Approval of the completed work must be obtained from the Engineer.
8. Finishing of Formed Surfaces.
- a. Apply rough form finish to exterior walls below grade not exposed to water.
  - b. Apply smooth form finish to exterior and interior walls and columns exposed to water.
  - c. Apply smooth form finish to interior walls and underside of floors, stairs and slabs.
  - d. In addition to the smooth form finish, apply a grout cleaned finish to concrete walls and surfaces exposed to public view and underside of formed floors, stairs or slabs.
  - e. Apply a rubber float grout mix to properly prepared concrete surface, only when approved by the Engineer. Mix shall have one part Portland cement to two parts fine sand in a 50% water and 50% Acryl #60 (Thoroseal or Acryl Set) mix or Acryl Set by Master Builders. Make a 10 x 10-foot sample on the concrete wall for the approval of the Engineer. Finished surface shall be a non dusting hard finish, when scratched with a 1/4-inch metal edge.
  - f. Finish concrete surface, interior or exterior, below or above water shall include all:
    - 1) Exposed concrete.
    - 2) Grout finished concrete.
    - 3) Painted surface concrete.
    - 4) Liquid membrane finished concrete shall comply with manufacturer's requirements.
    - 5) The entire surface of finished concrete shall have a smooth uniform surface, there shall be no offsets, visually bulges, or wavering in the finished surfaces. The joints must be accurately aligned, they can not be uneven or in or out, a higher and lower, there shall be no fins, projection or unevenness between forms.
    - 6) If after stripping the forms the Engineer determines that the finished concrete does not comply with any or all of the above requirements, the Contractor shall submit his proposal in writing to the Engineer as to his methods of correcting the work at no added cost to the Department, which shall include, but not limited to all grinding of fins, projections, unevenness between joints, form high spots and uneven spots.
    - 7) In addition to all other requirements, concrete surfaces exposed to public view, irrespective of size, area or location shall be completely clean and free of: (1) Stains of any nature, (2) Parts of forms or other wood of any nature, (3) laitance, (4) "Run-downs" of leaked water from secondary pours, (5) Nails, (6) Strips, (7) Ties and (8) all other extraneous, deleterious materials and/or substances

which may affect the finished appearance and condition of exposed concrete. Surfaces not meeting the above requirements are to be repaired and treated at no additional cost to the Department.

9. Slabs
  - a. Unless otherwise noted on the Plans, place strips alternately at maximum 20 feet center-to-center and to align with column centerline. Do not place adjacent strips until elapse of twenty four hours after first strip is placed. Place slabs on grade by the "strip-cast" method. Method to be reviewed by the Engineer. Provide saw-cut joints at maximum 20 feet center-to-center and to align with column center lines within four hours of final finishing.
  - b. Provide doweled construction joints where shown on the Plans.
  - c. Provide a hard steel troweled finish, free from trowel marks and irregularities, to slabs and floors.
  - d. Provide a light hair-broom finish to exterior slabs and floors exposed to public view. Leave hair-broom lines parallel to direction of the slab drainage.
  - e. Provide a stiff bristle broom finish to slabs and floors with slopes greater than 10 percent. Leave broom lines parallel to slope drainage.
  - f. Finish exposed edges of slabs, floors and tops of walls with a 1/4-inch radius edge unless a chamfer is called for on the Plans.
  
10. Curing and Protection
  - a. Comply with ACI 305 "Hot Weather Concreting", Chapter 4, with the supplements and modifications to ACI 301 listed herein.
  - b. Only concrete water curing for not less than 7 days (24 hours/day continuously) will be accepted; Burlene mats shall be used in curing. Water cure by ponding or continuous sprinkling covering complete surface with minimum runoff. The application of water to wall may be interrupted for grout cleaning only over the areas being cleaned at the time, and the concrete surfaces shall not be permitted to become dry during such interruption.
  - c. Begin all water curing as soon as concrete is set and concrete will not be damaged. Keep concrete and wall forms wet the first 24 hours. Remove forms as indicated in Formwork, Section 3.02-C.4, and continue with 7 day water curing. Recoat damaged surfaces subject to heavy or surfaces damaged by construction procedures within 3 hours of damage. Method of repair shall be approved by the Engineer.
  
11. Testing
  - a. Testing laboratory will be selected and paid for by the Department. Send results of all test to the Department and to the Contractor. The Contractor shall notify the Testing laboratory at least 24 hours before each concrete placing.
  - b. Obtain and mold 3 specimens for each fifty (50) cu. yds., or fraction thereof, of each class of concrete placed each day or as directed by the Engineer.

- c. Cure specimens from each sample in accordance with ASTM C31. Record in test report any deviations from this Standard.
- d. Test specimens in accordance with ASTM C39. Test one specimen at twenty eight (28) days for acceptance and, one specimen at three (3) days and seven (7) days respectively, for information. If one specimen in a test manifests evidence of improper sampling, molding or testing, it shall be discarded and the strength of the remaining cylinders shall be considered the test result.
- e. Contractors Superintendent shall color code on a set of structural drawings the extent of days work and date to conform to cylinders test.
- f. Perform slump test at discharge of mixer, one for each strength test in accordance with ASTM C143. In the event slump is excessive, testing laboratory will immediately notify the Contractor's superintendent and the Engineer's representative on site. The Contractor shall then reject all concrete with excessive slump and/or deposit time.
- g. Drying Shrinkage Test: A drying shrinkage test shall be conducted on the preliminary trial batch with the maximum water-cementitious materials ratio used to qualify each proposed concrete mix design using the concrete materials, including admixtures, that are proposed for the project. Three test specimens shall be prepared for each test. Drying shrinkage specimens shall be 4 x 4 x 11 inch prisms with an effective gauge length of 10 inches fabricated, cured, dried, and measured in accordance with ASTM C157 except with the following modifications:
  - 1) Specimens shall be removed from the molds at an age of 23 hours  $\pm$  1 hour after trial batching, shall be placed immediately in water at 73°F  $\pm$  3°F for at least 30 minutes, and shall be measured within 30 minutes thereafter to determine original length and then submerged in lime-saturated water as specified in ASTM C157. Measurement to determine expansion expressed as a percentage of original length shall be taken at age 7 days. The length at 7 days shall be the base length for drying shrinkage calculations ("0" days drying age). Specimens then shall be stored immediately in a humidity controlled room maintained at 73°F  $\pm$  3°F and 50%  $\pm$  4% relative humidity for the remainder of the test. Measurements to determine shrinkage expressed as percentage of base length shall be reported separately for 7, 14, and 21 days  $\pm$  4 hours of drying from "0" day after 7 days of moist curing.
  - 2) Drying shrinkage deformation for each specimen shall be computed as the difference between the base length (at "0" days drying age) and the length after drying at each test age. Results of the shrinkage test shall be reported to the nearest 0.001 percent. If drying shrinkage of any specimen deviates from the average for that test age more than 0.004 percent, the results for that specimen shall be

- disregarded.
- 3) The average drying shrinkage of each set of test specimens cast in the laboratory from a trial batch as measured at the 21 days drying age shall not exceed 0.036 percent and 0.042 percent at the 28-day drying stage for all concrete.
    - a) The maximum concrete shrinkage for specimens cast in the field shall not exceed the trial batch maximum shrinkage requirement by more than 25 percent.
    - b) If the required shrinkage limitation is not met during construction, the Contractor shall take any or all of the following actions at no additional cost to the Owner, for securing the specified shrinkage requirements. These actions may include changing the source or aggregates, cement and/or admixtures, including Tetra Guard AS 20 or approved equal; reducing water content; washing of aggregate to reduce fines; increasing the number of construction joints; modifying the curing requirements; or other actions designed to minimize shrinkage or the effects of shrinkage.
  - 4) Alkali-aggregate reactivity potential shall be determined in accordance with Appendix XI of ASTM C33. Aggregates shall be tested in accordance with ASTM C289 and C295 to determine potential reactivity. Aggregates which do not indicate a potential for alkali reactivity or reactive constituents may be used without further testing. Aggregates which indicate a potential for alkali reactivity shall be further tested in accordance with ASTM C227 or C1105, as appropriate, using a cement containing less than 0.6 percent alkalis. At the discretion of the Engineer, testing in addition to that indicated in Appendix XI of ASTM C33 may be performed on potentially reactive aggregates. Nonreactive aggregates shall be imported if, in the opinion of the Engineer, local aggregates exhibit unacceptable potential reactivity.
12. Evaluation and Acceptance of Concrete.
- a. If tests are insufficient or inadequate, test and evaluate by core tests. Failure of any concrete cylinder to meet specified requirements shall be deemed as non-complying and costs of additional tests to determine the adequacy or inadequacy shall be borne by the Contractor. Concrete rejected for any reason is to be removed and replaced, including labor, forms and reinforcing, to meet specifications at no additional cost to the Department and no additional time extension.
13. Additional Requirements.
- a. Submit shop drawings as required per General Conditions and



elsewhere in these specifications. Prime Contractor shall check and approve all shop drawings prior to submission. Do not fabricate any item requiring shop drawings until approval of shop drawings has been granted by the Department. Partial shop drawings are not accepted, submit drawings for complete submittal.

- b. Provide precast or cast-in-place reinforced concrete lintels at all masonry openings and sills at all windows. Reinforce to suit loads and span. Provide minimum 8-inch bearing at each end and, pour integral with columns where opening abuts columns.
- c. Sidewalks in R.O.W.: Provide poured-in-place 4-inch thick concrete slab, 3,000 psi concrete, with continuous 8-inch deep thickened slab edges. Isolate walks from vertical surfaces with 1/2-inch expansion joint material. Provide 1/2-inch expansion bituminous joint material flush with top of concrete slabs at 20 feet on center and tooled joints at 5 feet on center. Tool all open edges to a smooth radius and all edges adjacent to the forms.

**END OF SECTION**

**APPENDIX "A"**

**MIAMI-DADE COUNTY  
DEPARTMENT OF REGULATORY AND ECONOMIC RESOURCES  
DIVISION OF ENVIRONMENTAL RESOURCES MANAGEMENT**

**NOTICE TO ALL CONTRACTORS**

**( 1 Page )**

MIAMI DADE COUNTY, FLORIDA  
DEPARTMENT OF REGULATORY AND ECONOMIC RESOURCES  
701 NW 1ST COURT  
SUITE 200  
MIAMI, FLORIDA 33136  
(305) 372-6789

**NOTICE TO ALL CONTRACTORS INVOLVED IN ANY CONSTRUCTION  
ACTIVITY WHICH REQUIRES DEWATERING WITH ULTIMATE  
DISCHARGE INTO A CANAL, LAKE, DITCH OR STORM SEWER  
WHICH DISCHARGES INTO AN OPEN BODY OF WATER OR  
BISCAYNE BAY.**

Please be aware that if you are involved in any construction activity as above described, you are required to provide all necessary measures in order to maintain turbidity in the receiving body of water within the acceptable limits as established by the Florida Building Code. You must present a separate plan to be included with your building plans indicating your proposed measures or apply for a permit from Miami-Dade County Department of Regulatory and Economic Resources before your construction plans will receive final approval. For additional information, please contact Maria Molina, P.E. Chief, Water Control Section at 305-372-6769.

**APPENDIX "B"**

**MIAMI-DADE  
WATER AND SEWER DEPARTMENT**

**STANDARD DETAILS**

**( 40 Pages )**

1. ALL MATERIALS AND LABOR UNDER THIS PROJECT SHALL BE IN STRICT ACCORDANCE WITH THE REQUIREMENTS OF THE MIAMI-DADE WATER AND SEWER DEPARTMENT AND SHALL CONFORM TO THE STANDARDS AND SPECIFICATIONS AVAILABLE AND ON FILE WITH THE DEPARTMENT. SUBMIT SHOP DRAWINGS FOR ALL MATERIALS.
2. COVER OVER WATER OR SEWER FORCE MAINS SHALL BE 4'-0" MIN.
3. ALL MAIN LINE VALVES SHALL BE INSTALLED COMPLETE WITH 10" RISER PIPES AND NO. 3 OR 53 VALVE BOXES FIRE HYDRANTS AND SERVICE VALVES SHALL BE INSTALLED COMPLETE WITH 6" RISER PIPES AND NO. 2 VALVE BOXES.
4. ALL FORCE MAIN SERVICE CONNECTIONS INTO PRESSURE TRANSMISSION MAINS SHALL HAVE A SHUT OFF VALVE AND CHECK VALVE AT THE POINT OF ENTRY.
5. ALL GRAVITY SYSTEMS SHALL BE CONSTRUCTED IN ACCORDANCE WITH DEPARTMENT STANDARDS.
6. ALL WATER METERS WILL BE INSTALLED BY THE MIAMI-DADE WATER AND SEWER DEPARTMENT, PROVIDING THE APPROPRIATE CHARGES HAVE BEEN PREPAID.
7. FIRE HYDRANT REQUIREMENTS (NUMBER AND LOCATION) SHALL BE AS REQUIRED BY MIAMI-DADE COUNTY FIRE DEPARTMENT OR THE APPROPRIATE FIRE AGENCY WITH INSTALLATION IN ACCORDANCE WITH DEPARTMENT STANDARDS.
8. CONTRACTOR MUST CALL MDWASD INSPECTION DIVISION TO ARRANGE FOR A PRECONSTRUCTION MEETING 2 FULL BUSINESS DAYS PRIOR TO PROPOSED START OF CONSTRUCTION. CONTACT ONE CALL CENTER 48 HRS PRIOR TO EXCAVATION.
9. CONTRACT INSPECTOR WILL INSPECT ANY FACILITIES APPROVED BY THE DEPARTMENT. ALL OTHER REQUIREMENTS OF THE PERMITTING AGENCY SHALL BE IN ACCORDANCE WITH THEIR STANDARDS AND REQUIREMENTS.
10. WORK PERFORMED UNDER THIS PROJECT WILL NOT BE CONSIDERED AS COMPLETE UNTIL FINAL ACCEPTANCE OF THE SYSTEM BY THE DEPARTMENT AND UNTIL THE FOLLOWING DOCUMENTS ARE RECEIVED AND APPROVED BY THE DEPARTMENT:
  - a. EASEMENTS, IF REQUIRED
  - b. CONTRACTOR'S WAIVER AND RELEASE OF LIEN
  - c. ABSOLUTE BILL OF SALE
  - d.
    - i. CONTRACTOR'S LETTER OF WARRANTY (I.E., LETTER AGREEMENT)
    - ii DEVELOPER'S CONTRACT BOND (I.E., CONTRACT AGREEMENT).
  - e. "RECORD DRAWING" PRINTS (24"x 36") SHOWING SPECIFIC LOCATIONS, DEPTH, ETC. OF ALL WATER AND SEWER FACILITIES AS LOCATED BY A LICENSED SURVEYOR & MAPPER, ALONG WITH PRINTS OF "RECORD DRAWINGS" WHICH HAVE BEEN SIGNED AND SEALED BY A REGISTERED SURVEYOR & MAPPER. (No. OF PRINTS: 3-FOR WATER, 4-FOR GRAVITY SEWER AND 5-FOR FORCE MAIN OR PUMP STATION PROJECTS). Submittal of final CAD Files required.
  - f. H.R.S. LETTER OF RELEASE REQUIRED FOR ALL WATER PROJECTS
  - g. BILL OF SALE SKETCH (8½"x 11") FOR WATER AND SEWER, SEPARATELY
11. ALL NEW CONNECTIONS FROM EXISTING DEPARTMENT MAINS TO BE MADE BY DEPARTMENT FORCES ONLY. THE CONTRACTOR TO EXCAVATE AT REQUIRED LOCATIONS, PROVIDE AND INSTALL MATERIAL WITH FITTINGS, PRIOR TO TAP.
12. AN APPROVED PAVING AND DRAINAGE PLAN MUST BE SUBMITTED TO MDWASD FOR ALL NEW SUBDIVISIONS PRIOR TO APPROVAL OF WATER AND SEWER PERMIT PLANS, UPON REQUEST.
13. UNLESS OTHERWISE SPECIFIED, ALL TAPS 20 INCHES AND SMALLER FOR CONNECTIONS TO EXISTING MAINS WILL BE DONE BY DEPARTMENT FORCES. UNDER NO CIRCUMSTANCES WILL THE CONTRACTOR BE PERMITTED TO TAP EXISTING MAINS IN THE SIZE RANGE SPECIFIED ABOVE. THE TAPPING SLEEVE AND TAPPING VALVE ARE FURNISHED AND INSTALLED BY THE CONTRACTOR UNDER THE SUPERVISION OF THE INSPECTOR.

I T E M	CROSS REF.	SPEC. REF.

 MIAMI-DADE COUNTY <i>Delivering Excellence Every Day</i> WATER & SEWER DEPARTMENT	ISSUE DATE	APPROVED BY	STANDARD DETAIL <b>STANDARD REQUIREMENTS          WATER AND SEWER          CONSTRUCTION</b>	<b>GS</b> <b>0.5</b> SHEET 1 OF 2
	03/01/2010	V.F.C.		
	07/20/2016	D.V.		

1. AT THE COMPLETION OF ANY WATER AND SEWER JOB EITHER DONATION OR CONTRACT, THE CONTRACTOR SHALL SUBMIT:
  - a. RECORD DRAWING PRINTS WHICH HAVE BEEN SIGNED AND SEALED BY A FLORIDA LICENSED PROFESSIONAL SURVEYOR AND MAPPER (QTY. OF PRINTS AS REQUIRED BY THE DEPARTMENT).
  
2. "RECORD DRAWING" FORMAT:
  - a. 24"x 36" PRINTS
  - b. PDF FILE
  - c. CADD FILE (DWG OR DXF) ROTATED AND TRANSLATED TO STATE PLANE COORDINATES NAD 83 FLORIDA EAST ZONE
  - d. THE WORDS "RECORD DRAWING" IN LARGE LETTERS
  - e. TITLE BLOCK WITH DEPARTMENT DS, DW OR ER NUMBER AND PERTINENT INFORMATION
  - f. PREFERRED SCALE TO BE 1"= 40' HORIZONTALLY AND 1"= 4' VERTICALLY\*
  - g. STREET NOMENCLATURE
  - h. SEPARATE RECORD DRAWINGS FOR WATER AND SEWER
  - i. SEPARATE WATER AND SEWER PROFILE
  - j. STATIONING STARTING WITH 0+00 AT PERMANENT REFERENCE POINT (I.E.  $\odot$ ,  $\otimes$ , ETC.) OR AS SHOWN ON DESIGN PERMIT PLANS, AND TO RUN CONTINUOUSLY TO END OF MAIN
  - k. EASEMENTS, IF ANY, TIED TO PERMANENT REFERENCE POINT
  - l. IDENTIFY ALL CONTROL LINES (I.E. BLDG. LINE, PROPERTY LINE, R/W, ETC.)
  - m. ALL "PROPOSED" INFORMATION TO BE REMOVED FROM PRINTS, LEAVING ONLY RECORD DRAWING INFORMATION REFLECTED IN DRAWINGS
  
3. WATER "RECORD DRAWINGS" MUST INCLUDE:
  - a. PLANS SHOWING PIPE SIZE, MATERIAL AND OFFSET OF MAIN, DEFLECTIONS (IF ANY), STATION OF SERVICES, HYDRANTS, VALVES, FITTINGS, IF ANY, ALL IN STATE PLANE COORDINATES. UTILITY CROSSINGS SHALL BE CLEARLY IDENTIFIED AND LOCATED.
  - b. PROFILE SHOWING TOP OF GROUND AND TOP OF PIPE ELEVATIONS AT EVERY 100' STATION AND AT ANY CHANGE IN GRADE (WITH CORRESPONDING STATION), PIPE SIZE AND PIPE MATERIALS REFERENCED TO PLAN.
  
4. SEWER "RECORD DRAWINGS" MUST INCLUDE:
  - a. PLAN SHOWING MANHOLE NUMBER, PIPE SIZE AND PIPE MATERIAL OF PIPE, DEFLECTION, SLOPE OF GRAVITY SEWER, LOCATION OF LATERALS WITH REFERENCE TO MANHOLE AND CLEANOUTS.
  - b. THE NORTHERLY AND EASTERLY COORDINATES ON ALL FIELD OBTAINED MEASUREMENTS AND PROVIDED ON ALL RECORD DRAWING SUBMITTALS
  - c. PROFILE SHOWING MANHOLE NUMBER (AS PER PLAN), RIM AND INVERT ELEVATIONS (IF MORE THAN ONE INVERT, LABEL NORTH, SOUTH, ETC.), AND STATION STARTING AT 0+00 AT DOWNSTREAM MANHOLE.
  
5. FORCE MAIN "RECORD DRAWING" SAME AS WATER MAIN.
  
6. EACH RECORD DRAWING SHALL SHOW THE FLORIDA STATE PLANE COORDINATES (CURRENT READJUSTMENT) OF ALL THE MANHOLES AND VALVES AND OF AT LEAST TWO HORIZONTAL CONTROL POINTS PROPERLY IDENTIFIED AND LOCATED WITHIN THE PROJECT.

\* OTHER SCALE MAY BE PERMITTED, BUT MUST BE APPROVED BY THE DEPARTMENT PRIOR TO PREPARATION OF DRAWINGS.

I T E M	CROSS REF.	SPEC. REF.

 Delivering Excellence Every Day WATER & SEWER DEPARTMENT	<u>ISSUE DATE</u>	<u>APPROVED BY</u>	S T A N D A R D   D E T A I L  <b>"RECORD DRAWING" REQUIREMENTS</b>	<b>GS</b> <b>0.5</b> SHEET 2 OF 2
	03/11/2009	V.F.C.		
	07/20/2016	D.V.		

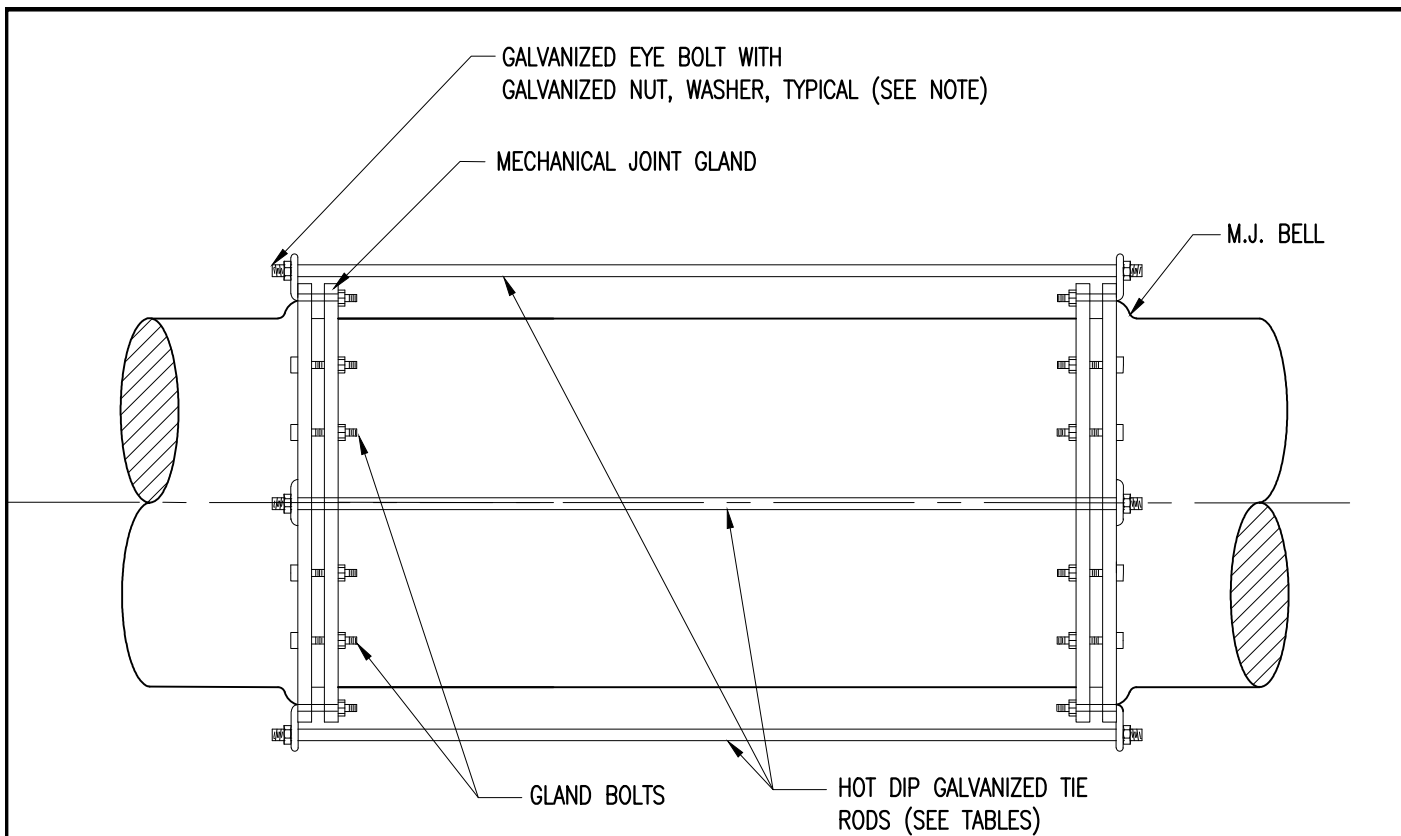

PRESSURE AT 150 P.S.I.		
PIPE SIZE	ROD DIAMETER	No. OF RODS
8" & SMALLER	3/4"	3
12"	3/4"	4
16"	3/4"	6
20"	3/4"	8
24"	3/4"	12
30"	1"	14
36"	1"	14
42"	1- 1/4"	16
48"	1- 1/4"	16

**NOTES:**

1. EYE BOLT REPLACES GLAND BOLT AT TIE ROD LOCATIONS.
2. IN LIEU OF BELL/ROD RESTRAINTS, MECHANICAL JOINT RESTRAINTS MAY BE USED

ITEM	CROSS REF.	SPEC. REF.



<u>ISSUE DATE</u>	<u>APPROVED BY</u>
11/01/2006	V.E.F.
07/20/2016	D.V.

STANDARD DETAIL  
**TYPICAL TIE-ROD  
 DETAILS**

**GS  
 1.0  
 SHEET 1 OF 1**

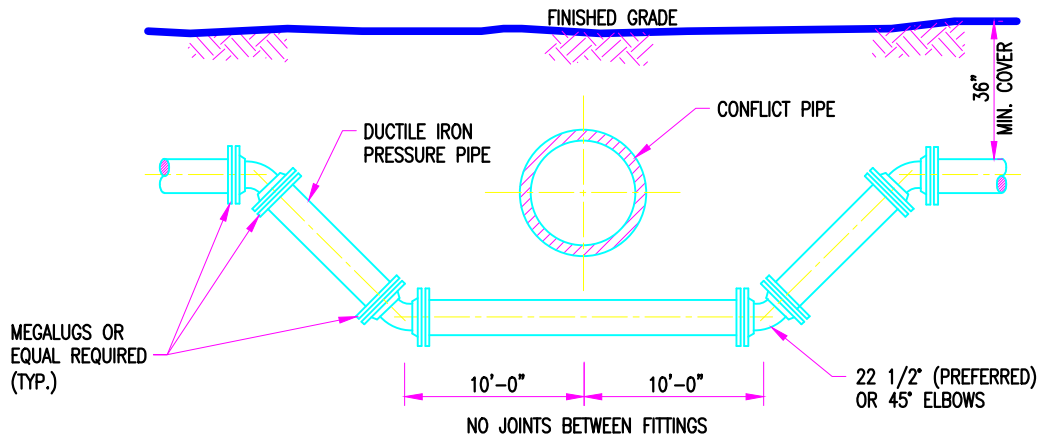

### FITTING TYPE

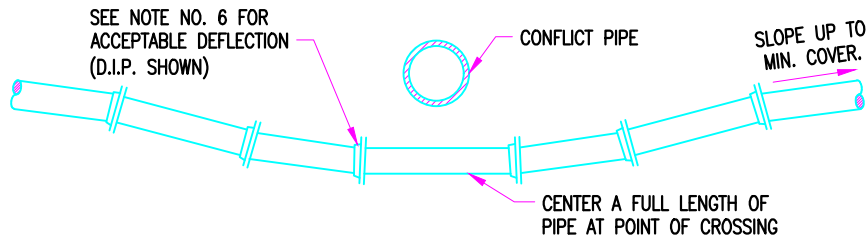

### DEFLECTION TYPE

#### NOTES:

1. STORM SEWER, GRAVITY WASTEWATER AND RECLAIMED WATER MAIN CROSSING UNDER POTABLE WATER MAINS SHALL BE LAID TO PROVIDE A MINIMUM VERTICAL DISTANCE OF TWELVE (12) INCHES BETWEEN THE INVERT OF THE UPPER PIPE AND THE CROWN OF THE LOWER PIPE. WHERE THIS MINIMUM SEPARATION CANNOT BE MAINTAINED, THE CROSSING SHALL BE ARRANGED SO THAT THE STORM/WASTEWATER/RECLAIMED WATER PIPE JOINTS AND POTABLE WATER MAIN JOINTS ARE EQUIDISTANT FROM THE POINT OF CROSSING WITH NO LESS THAN TEN (10) FEET BETWEEN ANY TWO JOINTS, BOTH PIPES SHALL BE D.I.P., AND THE MINIMUM VERTICAL SEPARATION SHALL BE 6 INCHES. WHERE THERE IS NO ALTERNATIVE TO STORM/WASTEWATER/RECLAIMED WATER PIPES CROSSING OVER A POTABLE WATER MAIN, THE CRITERIA FOR MINIMUM 12" VERTICAL SEPARATION BETWEEN LINES AND JOINT ARRANGEMENT, AS STATED ABOVE, SHALL BE REQUIRED, AND BOTH PIPES SHALL BE D.I.P. IRRESPECTIVE OF SEPARATION. D.I.P. IS NOT REQUIRED FOR STORM SEWERS.
2. WHENEVER POSSIBLE MAINTAIN MIN. TEN (10) FEET HORIZONTAL DISTANCE (WALL TO WALL) BETWEEN POTABLE WATER MAIN AND STORM SEWER, WASTEWATER MAIN, OR FORCE MAIN (A MIN. 6' SEPARATION MAY BE APPROVED ON A CASE BY CASE BASIS.) MAINTAIN MIN. THREE (3) FEET HORIZONTAL DISTANCE (WALL TO WALL) BETWEEN RECLAIMED WATER MAIN AND POTABLE WATER MAIN, STORM SEWER, WASTEWATER GRAVITY MAIN OR FORCE MAIN.
3. FORCE MAIN CROSSING POTABLE WATER MAIN OR RECLAIMED WATER MAIN SHALL BE LAID TO PROVIDE A MINIMUM VERTICAL DISTANCE OF TWELVE (12) INCHES BETWEEN THE OUTSIDE OF THE FORCE MAIN AND OUTSIDE OF THE POTABLE WATER MAIN OR RECLAIMED WATER MAIN WITH THE POTABLE WATER MAIN OR RECLAIMED WATER MAIN CROSSING OVER THE FORCE MAIN.
4. FITTINGS SHALL BE RESTRAINED.
5. THE DEFLECTION TYPE CROSSING IS PREFERRED.
6. DO NOT EXCEED 50% OF MANUFACTURERS RECOMMENDED MAXIMUM JOINT DEFLECTION FOR DUCTILE IRON PIPE. PVC PIPE CURVATURE MAY ONLY BE ACCOMPLISHED BY INSTALLING APPROPRIATE BENDS.
7. POTABLE WATER SERVICE LINES SHALL CROSS OVER WASTEWATER MAINS WITH MIN. 12" VERTICAL SEPARATION. WHERE THIS MIN. SEPARATION CAN NOT BE MAINTAINED, THE WATER SERVICE SHALL BE ENCASED IN A MIN. 10' LONG CASING CENTERED OVER THE CROSSING WITH MIN. 6" VERTICAL SEPARATION.
8. WASTEWATER MAINS, WATER MAINS, STORM PIPES AND OTHER UTILITY PIPES SHALL CROSS PERPENDICULAR WHENEVER POSSIBLE.

ITEM	CROSS REF.	SPEC. REF.



<u>ISSUE DATE</u>	<u>APPROVED BY</u>
07/20/2016	D.V.

STANDARD DETAIL

**POTABLE WATER MAIN/FORCE MAIN  
PRESSURE PIPE CONFLICT DETAIL**

**GS**  
**1.1**  
SHEET 1 OF 1

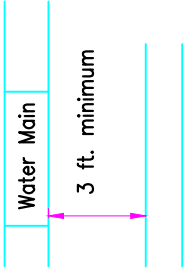
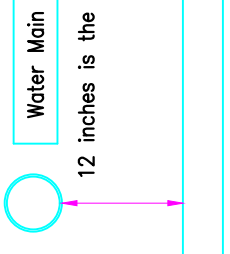
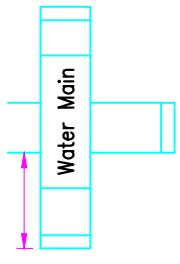
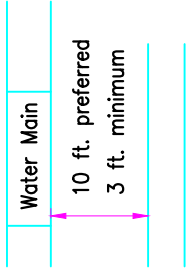
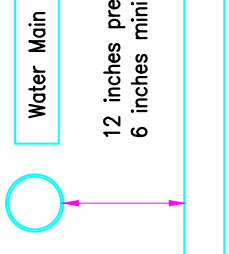
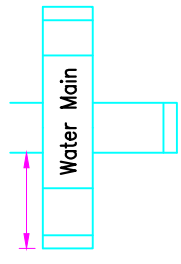
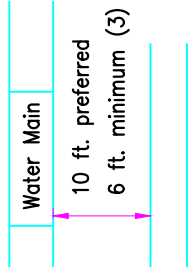
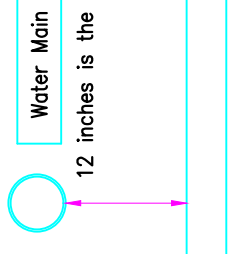
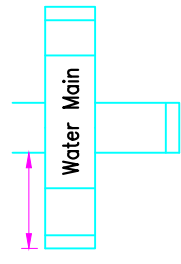

**LOCATION OF PUBLIC WATER SYSTEM MAINS ACCORDANCE WITH F.A.C. RULE 62-555.314**

OTHER PIPE	HORIZONTAL SEPARATION	CROSSINGS (1)	JOINT SPACING @ CROSSINGS (FULL LENGTH OF PIPE CENTERED)
Storm Sewer; Stormwater Force Main; Reclaimed Water (2)	 <p>Water Main 3 ft. minimum</p>	 <p>Water Main 12 inches is the minimum.</p>	 <p>Alternate: 3 ft minimum</p>
Vacuum Sanitary Sewer	 <p>Water Main 10 ft. preferred 3 ft. minimum</p>	 <p>Water Main 12 inches preferred 6 inches minimum</p>	 <p>Alternate: 3 ft minimum</p>
Gravity or Pressure; Sanitary Sewer; Sanitary Sewer Force Main; Reclaimed Water (4)	 <p>Water Main 10 ft. preferred 6 ft. minimum (3)</p>	 <p>Water Main 12 inches is the minimum.</p>	 <p>Alternate: 6 ft minimum</p>
On-Site Sewage Treatment & Disposal System	10 ft minimum	-	-

**NOTES:**

- (1) WATER MAIN SHOULD BE ABOVE OTHER PIPE. WHEN WATER MAIN MUST BE BELOW OTHER PIPE, THE MINIMUM SEPARATION IS 12 INCHES.
- (2) RECLAIMED WATER REGULATED UNDER PART III OF CHAPTER 62-610, F.A.C.
- (3) 3 FT. GRAVITY SANITARY SEWER WHERE THE BOTTOM OF THE WATER MAIN IS LAID AT LEAST 6 INCHES ABOVE THE TOP OF THE GRAVITY SANITARY SEWER.
- (4) RECLAIMED WATER NOT REGULATED UNDER PART III OF CHAPTER 62-610, F.A.C.

ITEM	CROSS REF.	SPEC. REF.



ISSUE DATE: 10/1/2017  
APPROVED BY: D.V.

STANDARD DETAIL  
POTABLE WATER MAIN,  
WASTEWATER & STORM SEWER CONFLICT

GS  
1.5  
SHEET 1 OF 2

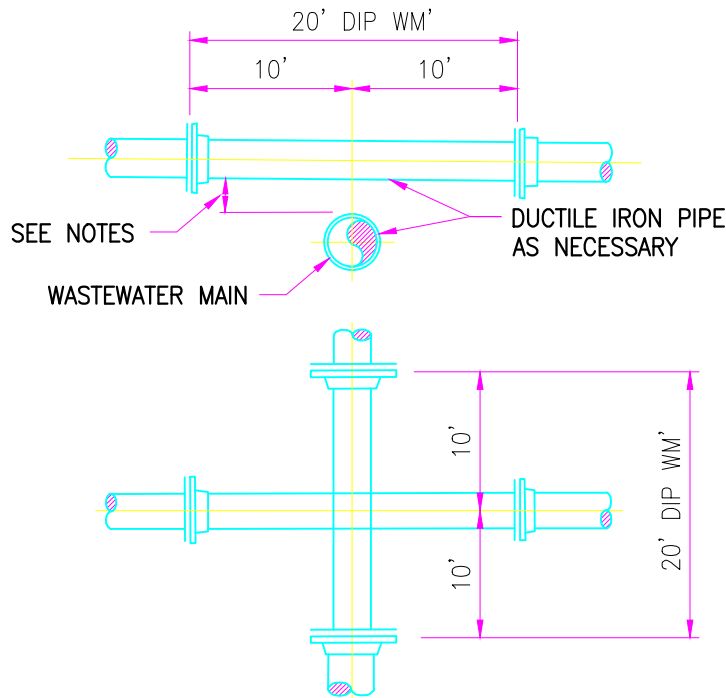

**NOTES:**

1. STORM SEWER, GRAVITY WASTEWATER AND RECLAIMED WATER MAIN CROSSING UNDER POTABLE WATER MAINS SHALL BE LAID TO PROVIDE A MINIMUM VERTICAL DISTANCE OF TWELVE (12) INCHES BETWEEN THE INVERT OF THE UPPER PIPE AND THE CROWN OF THE LOWER PIPE. WHERE THIS MINIMUM SEPARATION CANNOT BE MAINTAINED, THE CROSSING SHALL BE ARRANGED SO THAT THE STORM/WASTEWATER/RECLAIMED WATER PIPE JOINTS AND POTABLE WATER MAIN JOINTS ARE EQUIDISTANT FROM THE POINT OF CROSSING WITH NO LESS THAN TEN (10) FEET BETWEEN ANY TWO JOINTS, BOTH PIPES SHALL BE D.I.P., AND THE MINIMUM VERTICAL SEPARATION SHALL BE 6 INCHES. WHERE THERE IS NO ALTERNATIVE TO STORM/WASTEWATER/RECLAIMED WATER PIPES CROSSING OVER A POTABLE WATER MAIN, THE CRITERIA FOR MINIMUM 12" VERTICAL SEPARATION BETWEEN LINES AND JOINT ARRANGEMENT, AS STATED ABOVE, SHALL BE REQUIRED, AND BOTH PIPES SHALL BE D.I.P. D.I.P. IS NOT REQUIRED FOR STORM SEWERS.
2. WHENEVER POSSIBLE MAINTAIN MIN. TEN (10) FEET HORIZONTAL DISTANCE (WALL TO WALL) BETWEEN POTABLE WATER MAIN AND STORM SEWER, WASTEWATER MAIN, OR FORCE MAIN (A MIN. 6' SEPARATION MAY BE APPROVED ON A CASE BY CASE BASIS). MAINTAIN MIN. THREE (3) FEET HORIZONTAL DISTANCE (WALL TO WALL) BETWEEN RECLAIMED WATER MAIN AND POTABLE WATER MAIN, STORM SEWER, WASTEWATER GRAVITY MAIN OR FORCE MAIN.
3. FORCE MAIN CROSSING POTABLE WATER MAIN OR RECLAIMED WATER MAIN SHALL BE LAID TO PROVIDE A MINIMUM VERTICAL DISTANCE OF TWELVE (12) INCHES BETWEEN THE OUTSIDE OF THE FORCE MAIN AND OUTSIDE OF THE POTABLE WATER MAIN OR RECLAIMED WATER MAIN WITH THE POTABLE WATER MAIN OR RECLAIMED WATER MAIN CROSSING OVER THE FORCE MAIN.
4. WASTEWATER LATERALS SHALL CROSS UNDER POTABLE WATER MAINS WITH A MIN. 12" VERTICAL SEPARATION WHENEVER POSSIBLE. WHERE THIS MINIMUM SEPARATION CANNOT BE MAINTAINED, A 20' SECTION OF DUCTILE IRON PIPE POTABLE WATER MAIN CENTERED ON THE CROSSING IS REQUIRED AND THE MINIMUM VERTICAL SEPARATION SHALL BE 6". WHERE THERE IS NO ALTERNATIVE TO A WASTEWATER LATERAL PIPE CROSSING OVER A POTABLE WATER MAIN, A MINIMUM 12" VERTICAL SEPARATION IS REQUIRED, THE LATERAL SHALL BE P.V.C. C-900 SDR18 OR BETTER, THE POTABLE WATER MAIN SHALL BE D.I.P. AND THE PIPE JOINTS SHALL BE EQUIDISTANT FROM THE POINT OF CROSSING.
5. POTABLE WATER SERVICE LINES SHALL CROSS OVER WASTEWATER MAINS WITH A MIN. 12" VERTICAL SEPARATION. WHERE THIS MIN. SEPARATION CAN NOT BE MAINTAINED, THE WATER SERVICE SHALL BE ENCASED IN A MIN. 10' LONG PVC CASING CENTERED OVER THE CROSSING WITH MIN. 6" VERTICAL SEPARATION.
6. WASTEWATER MAINS, WATER MAINS, STORM PIPES AND OTHER UTILITY PIPES SHALL CROSS PERPENDICULAR WHENEVER POSSIBLE.

I T E M	CROSS REF.	SPEC. REF.



<u>ISSUE DATE</u>	<u>APPROVED BY</u>
10/1/2017	D.V.

S T A N D A R D   D E T A I L

**WATER AND SEWER  
MAINS CROSSING**

**GS**  
**1.5**  
SHEET 2 OF 2

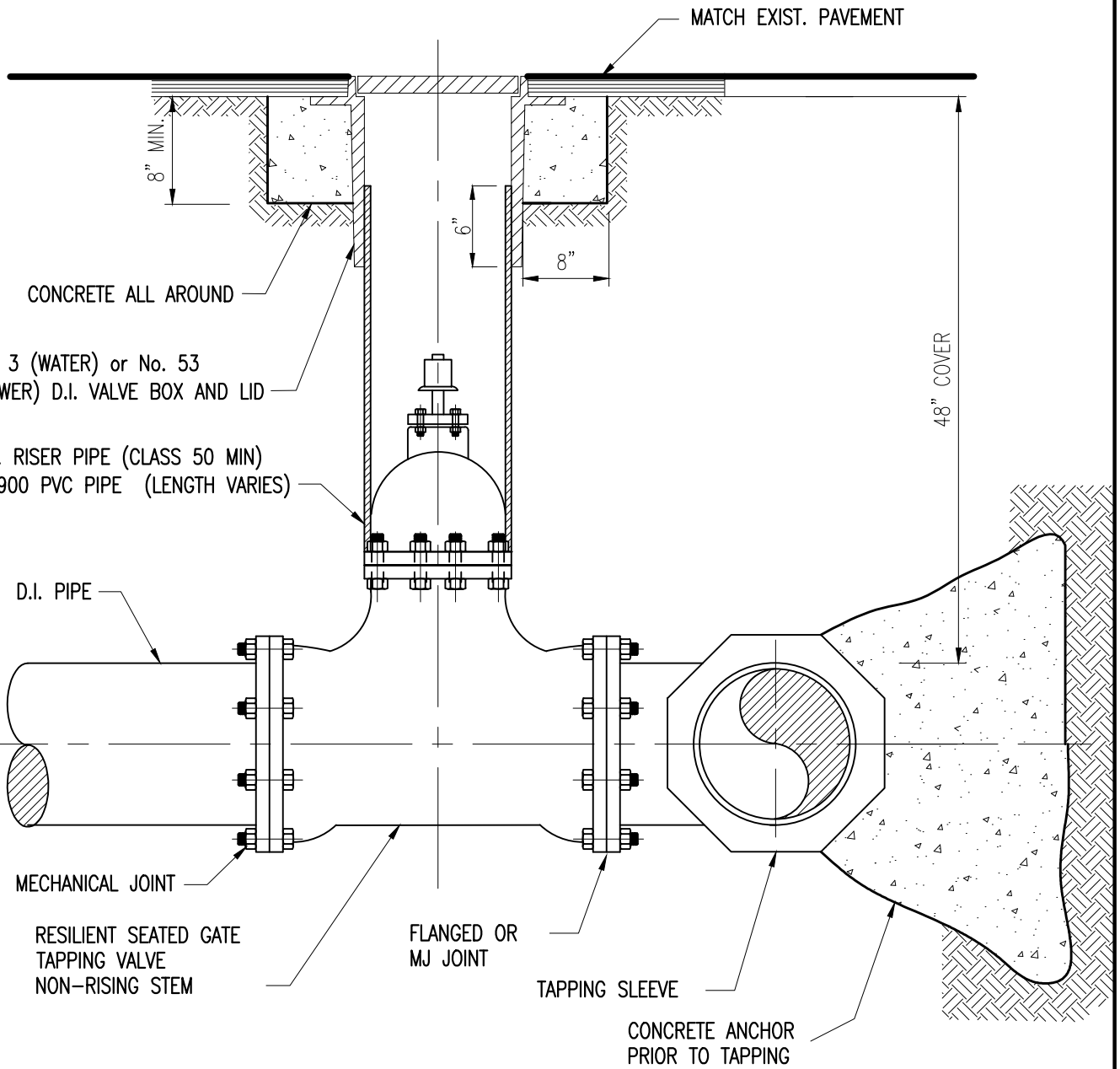

**NOTES:**

1. RESILIENT SEATED GATE TAPPING VALVE CAN BE USED FOR SEWER CONNECTION.
2. 18" CLEARANCE FROM FITTINGS AND BELLS.
3. TAPPING VALVE AND SLEEVE SHALL BE PRESSURE TESTED AT 150 "psi" PRIOR TO BEING TAPPED.
4. TAPPING ON CONCRETE MAINS SHALL BE PRESSURE TESTED AT A LOWER PRESSURE THAN THE ACTIVE OPERATING PRESSURE OF THE MAIN.

No.53 Valve Box	SS 13.0	
No.3 Valve Box	WS 3.11	
INSTALLATION	GS 1.8	
I T E M	CROSS REF.	SPEC. REF.



<u>ISSUE DATE</u>	<u>APPROVED BY</u>
01/22/2009	V.F.C.
07/20/2016	D.V.

STANDARD DETAIL  
**TYPICAL TAPPING  
 VALVE SETTING  
 (16" AND SMALLER)**

**GS  
 1.7**  
 SHEET 1 OF 1

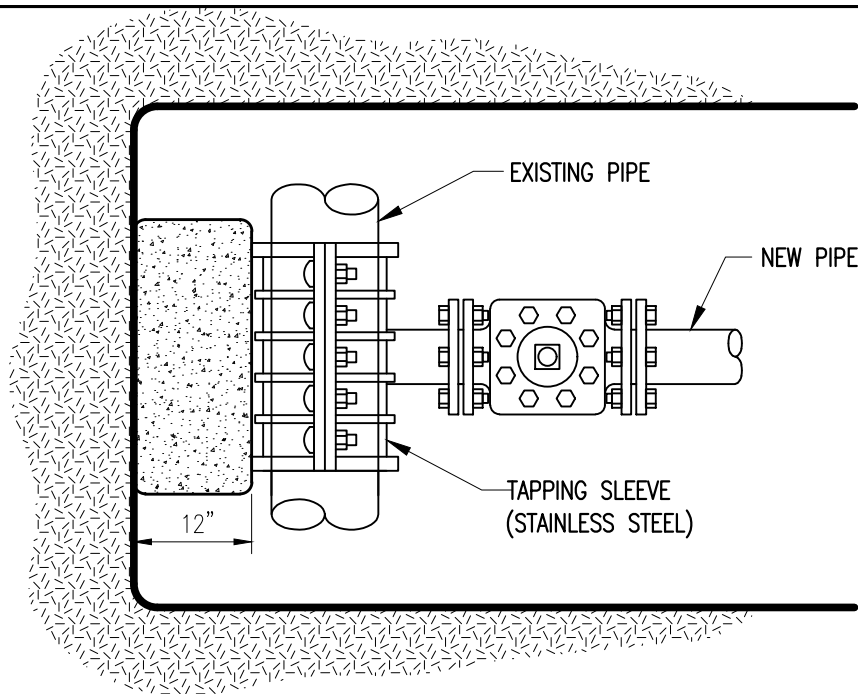

**PLAN VIEW**

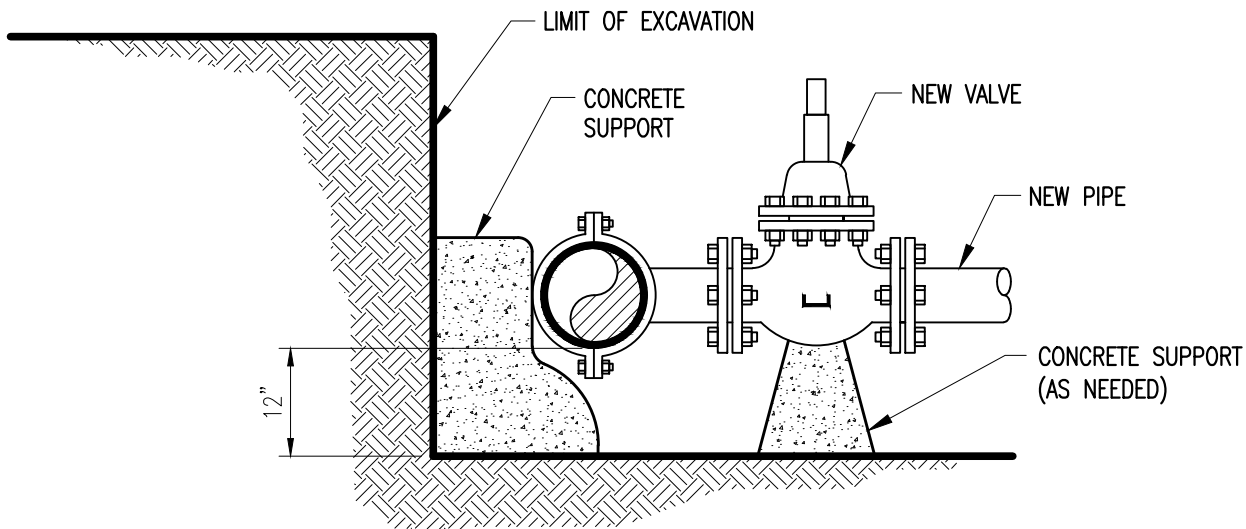

**SECTION**

**PROCEDURE:**

1. CONTRACTOR TO INSTALL AND PRESSURE TEST TAPPING SLEEVE AND VALVE, WITNESSED BY M-D.WASD INSPECTOR.
2. ALL TAPS LARGER THAN 20 INCHES SMALL BE DONE BY A TAPPING SPECIALIST WITH CREDENTIALS ACCEPTABLE TO THE DEPARTMENT.
3. CONTRACTOR TO SUPPLY EQUIPMENT TO HANDLE TAPPING MACHINE & DEWATERING EQUIPMENT.
4. 18" CLEARANCE FROM FITTINGS AND BELLS.
5. TAPPING VALVE AND SLEEVE SHALL BE PRESSURE TESTED AT 150 psi PRIOR TO BEING TAPPED.

ITEM	CROSS REF.	SPEC. REF.

 WATER & SEWER DEPARTMENT	<u>ISSUE DATE</u>	<u>APPROVED BY</u>	STANDARD DETAIL <b>TAPPING SLEEVE AND VALVE          INSTALLATION          (PROPOSED)</b>	<b>GS          1.8          SHEET 1 OF 1</b>
	01/22/2009	V.F.C.		
	07/20/2016	D.V.		

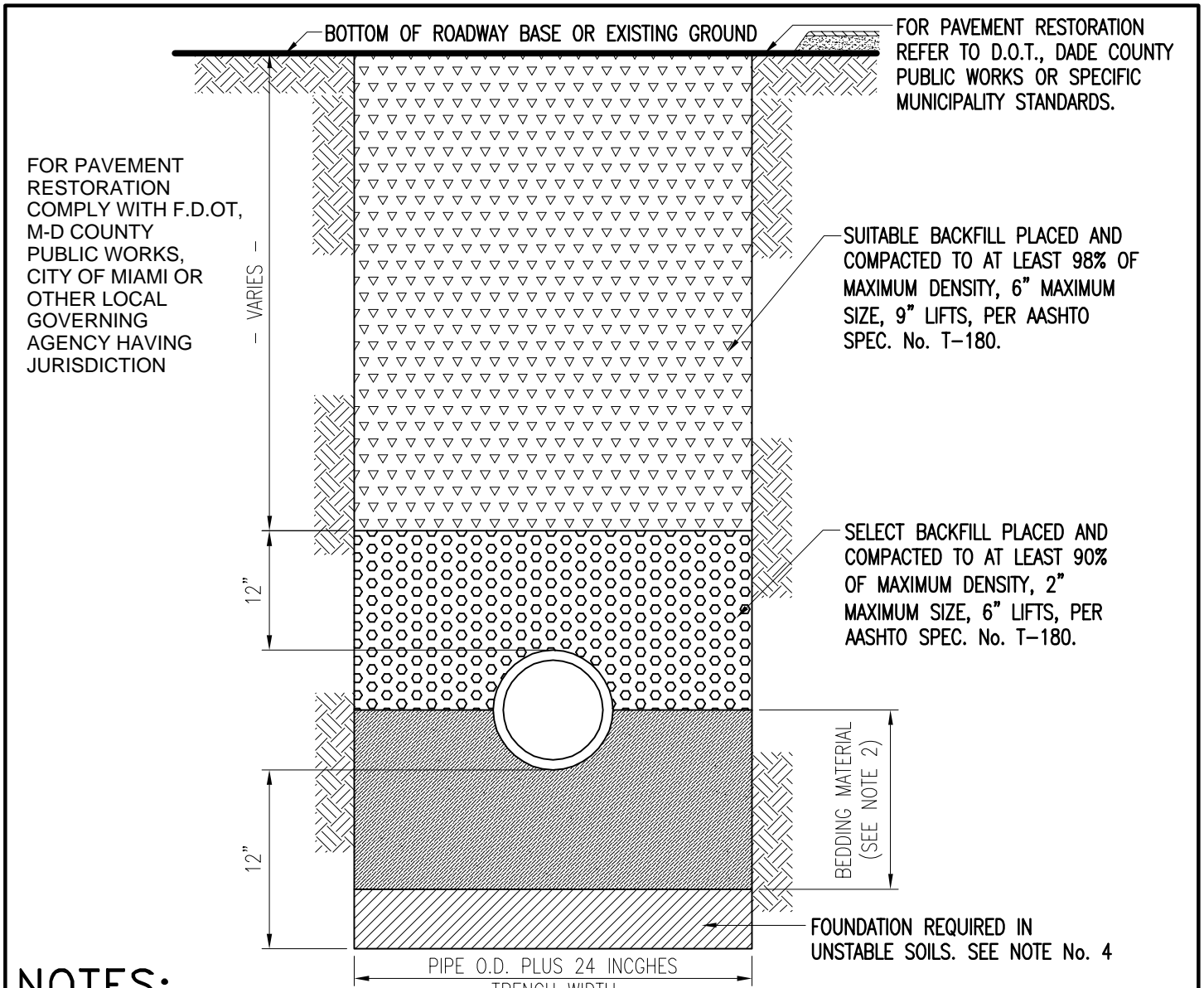

**NOTES:**

- 1 FOR EXCAVATION AND BACKFILL AROUND MANHOLES, APPURTENANCES, OR IN WATER, REFER TO PROVISIONS WITHIN THE SPECIFICATIONS.
- 2 UNLESS OTHERWISE SPECIFIED, BEDDING MATERIAL SHALL CONSIST OF SELECT BACKFILL MATERIAL 2" MAX. SIZE, OR WASHED AND GRADED LIMEROCK (3/8"-7/8"), COMPACTED TO AT LEAST 90° OF MAX. DENSITY, 6" LIFTS, PER AASHTO SPEC. No. T-180.
- 3 WHERE REQUIRED, SHEETING AND SHORING SHALL BE IN ACCORDANCE WITH SPECIFICATIONS.
- 4 WHERE UNSTABLE SOILS ARE ENCOUNTERED, INCLUDING PEAT, MUCK OR OTHER ORGANIC SOILS, ELASTIC SILT AND CLAYS BELOW THE WATER TABLE, A FOUNDATION IS REQUIRED. COMPACTED TO AT LEAST 90° OF MAX. DENSITY, 6" LIFTS, PER AASHTO SPEC. NO. T-180. FOUNDATION MATERIAL SHALL BE SELECT BACKFILL MATERIAL, 2" MAXIMUM SIZE 6" LIFTS EXTEND EXCAVATION AT LEAST 2' DEEPER FOR FOUNDATION ENLESS SUITABLE MATERIAL IS FOUND AT A LESSER DEPTH, GREATER DEPTHS MAY BE REQUIRED FOR EXTREMELY POOR CONDITIONS.
- 5 POLYETHYLENE ENCASEMENT OF CAST IRON VALVES, PIPE AND FITTINGS, IF REQUIRED BY THE DEPARTMENT, SHALL BE PER ANSI/AWWA C105/A21.5, METHOD A, B OR C FOR TYPE I CLASS C TUBE, MIN. 8 MILS

ITEM	CROSS REF.	SPEC. REF.
------	------------	------------

	ISSUE DATE	APPROVED BY	<b>STANDARD DETAIL</b> <b>TYPICAL TRENCH BACKFILL</b> <b>FOR D.I. WATER AND FORCE</b> <b>MAINS</b>	<b>GS</b> <b>1.9</b> SHEET <b>1</b> OF <b>1</b>
	11/01/2006	V.E.F.		
	07/20/2016	D.V.		

**MINIMUM LENGTH OF PIPE (FEET) TO BE RESTRAINED**

(SOURCES: EBAA IRON RESTRAINT LENGTH CALCULATION PROGRAM FOR PVC PIPE, RELEASE 3.1, AND  
DIPRA THRUST RESTRAINT FOR DUCTILE IRON PIPE, RELEASE 3.2)

FITTING TYPE		PIPE SIZE											
		4"	6"	8"	10"	12"	16"	20"	24"	30"	36"	42"	48"
90° HORIZONTAL BEND		14	20	25	30	35	45	54	62	73	84	93	101
45° HORIZONTAL BEND		6	8	11	13	15	19	22	26	30	35	38	42
22.5° HORIZONTAL BEND		3	4	5	6	7	9	11	12	15	17	18	20
11.25° HORIZONTAL BEND		1	2	3	3	4	4	5	6	7	8	9	10
90° VERTICAL OFFSET	UPPER BEND	55	79	103	125	147	189	228	266	319	368	412	454
	LOWER BEND	22	38	49	59	69	88	106	123	145	165	184	201
45° VERTICAL OFFSET	UPPER BEND	22	32	42	51	60	77	93	109	131	151	170	187
	LOWER BEND	10	14	19	23	28	35	43	50	59	67	75	82
22.5° VERTICAL OFFSET	UPPER BEND	7	12	17	21	26	34	42	49	60	70	78	87
	LOWER BEND	2	4	6	8	10	14	17	21	25	29	33	36
11.25° VERTICAL OFFSET	UPPER BEND	3	4	6	9	11	15	19	22	28	32	37	41
	LOWER BEND	1	1	1	2	3	5	7	8	10	12	14	16
PLUG (DEAD END)		32	45	59	70	83	107	129	151	190	220	244	270
IN-LINE VALVE		32	45	59	70	83	107	129	151	100	110	125	135
TEE (BRANCH RESTRAINT)	4" x 0	23											
	6" x 0	21	35										
	8" x 0	18	34	47									
	10" x 0	16	32	46	58								
	12" x 0	13	30	44	57	69							
	16" x 0	7	26	41	55	67	90						
	20" x 0	1	21	38	52	65	88	109					
	24" x 0	1	16	34	49	62	86	108	129				
	30" x 0	8	28	44	58	83	106	127	154				
	36" x 0	1	1	22	39	54	80	103	124	153	179		
	42" x 0	1	1	15	33	49	77	100	122	151	177	201	
	48" x 0	1	1	7	27	44	73	97	120	149	176	200	222
REDUCER (LARGER PIPE RESTRAINT)	6" x 0	23											
	8" x 0	38	25										
	10" x 0	57	43	24									
	12" x 0	72	60	44	41								
	16" x 0	99	90	78	75	45							
	20" x 0	123	116	107	105	81	45						
	24" x 0	146	140	132	131	111	82	45					
	30" x 0	157	153	148	141	133	113	87	56				
	38" x 0	182	179	175	169	163	147	126	101	56			
	42" x 0	205	202	199	194	189	175	158	138	100	54		
	48" x 0	226	224	221	217	213	201	187	169	138	98	53	

**NOTES:**

- THE DATA IN THE ABOVE TABLE ARE BASED UPON THE FOLLOWING INSTALLATION CONDITIONS:  
 1A: SOIL TYPE-SAND  
 1B: TEST PRESSURE-150 PSI  
 1C: DEPTH OF BURY-4'  
 1D: TRENCH TYPE-3  
 1E: SAFETY FACTOR-1.5  
 1F: VERTICAL OFFSET-3'  
 1G: MINIMUM PIPE LENGTH ALONG TEE RUN-5'
- THE RESTRAINED PIPE LENGTHS APPLY TO DUCTILE IRON AND PVC PIPE.
- ALL JOINTS BETWEEN UPPER AND LOWER BENDS SHALL BE RESTRAINED.
- RESTRAINED PIPE LENGTHS APPLY TO PIPE ON BOTH SIDES OF VALVES AND FITTINGS.

ITEM	CROSS REF.	SPEC. REF.



ISSUE DATE	APPROVED BY
04/10/2014	J.F.
07/20/2016	D.V.

STANDARD DETAIL  
**STANDARD REQUIREMENTS FOR  
 WATER AND SEWER MECHANICAL  
 THRUST RESTRAINT**

**GS  
 2.0  
 SHEET 1 OF 1**

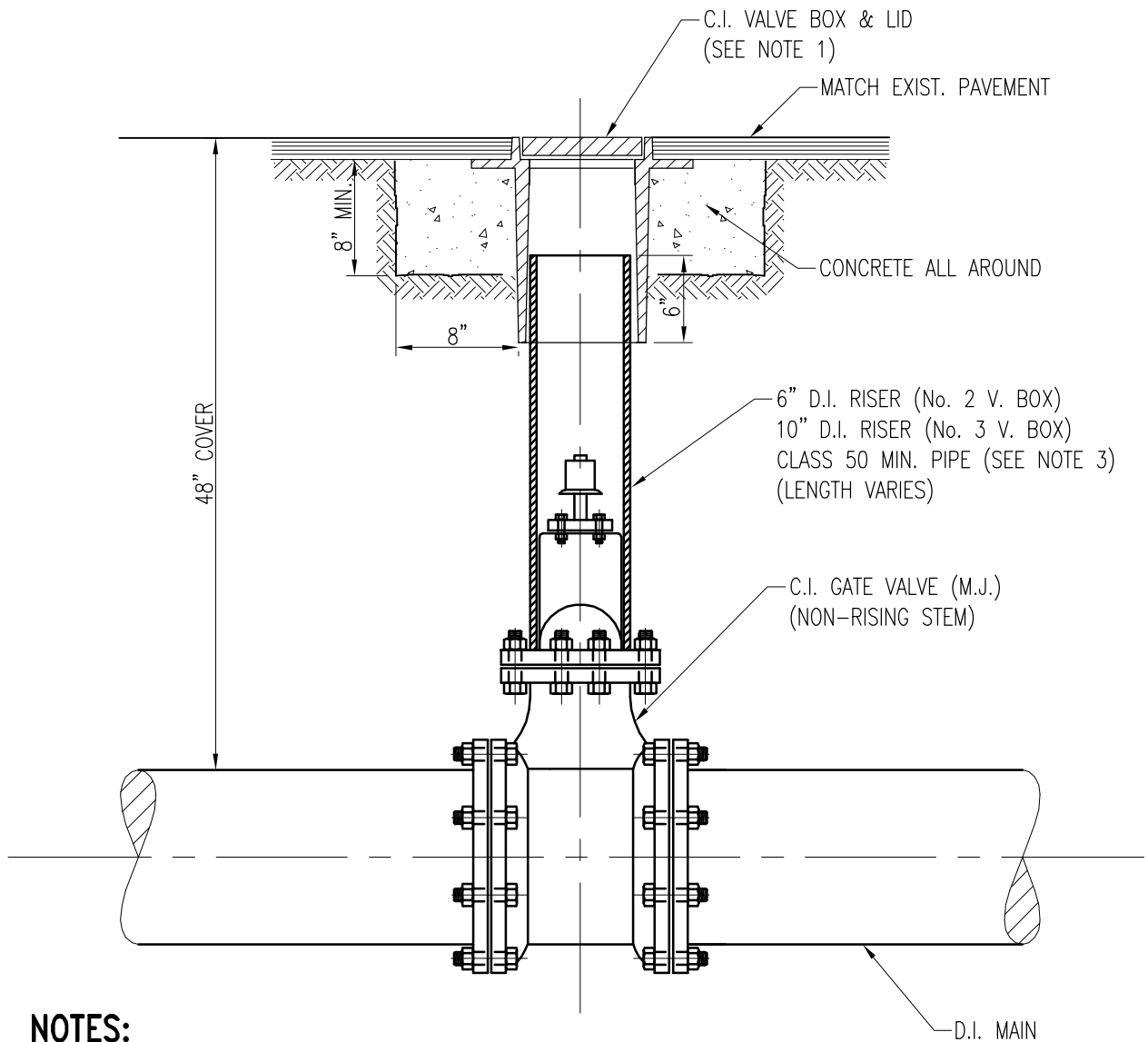

**NOTES:**

1. USE No. 2 VALVE BOX FOR:

- FIRE HYDRANT VALVES
- FIRE LINE SERVICES & DOMESTIC SERVICES
- 2" MAINS IN EASEMENTS
- BYPASS VALVES

2. USE No. 3 VALVE BOX FOR ALL MAIN LINE VALVES.

3. PVC C900 PIPE CAN BE USED FOR RISER IN LIEU OF DUCTILE IRON.

4. IF USED FOR RECLAIMED WATER VALVES, THE LID SHALL BE MARKED "R" AND BOTH THE LID AND THE RISER PIPE ARE TO BE COLORED PURPLE PANTONE 522C.

No. 3 VALVE BOX & LID	WS 3.11	
No. 2 VALVE BOX & LID	WS 3.10	
I T E M	CROSS REF.	SPEC. REF.



ISSUE DATE	APPROVED BY
10/10/2008	V.F.C.

STANDARD DETAIL  
**TYPICAL GATE VALVE SETTING  
 (SMALLER THAN 16")**

**WS**  
**1.0**  
 SHEET 1 OF 1

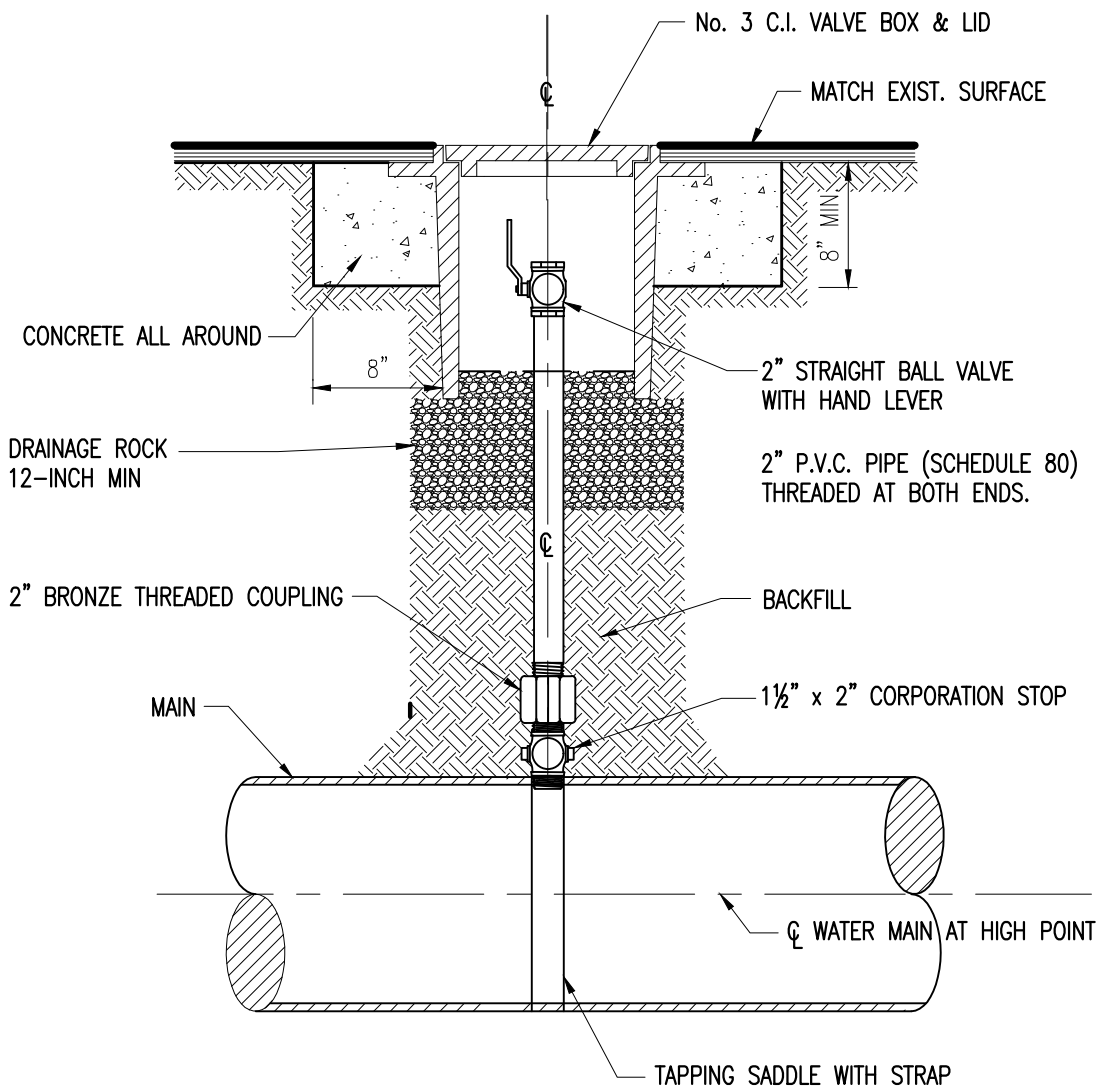

No. 3 VALVE BOX & LID	WS 3.11	
ITEM	CROSS REF.	SPEC. REF.



<u>ISSUE DATE</u>	<u>APPROVED BY</u>
10/06/2009	V.F.C.
06/09/2016	D.V.

STANDARD DETAIL

**MANUAL  
AIR RELEASE VALVE**

**WS  
1.60**

SHEET 1 OF 1



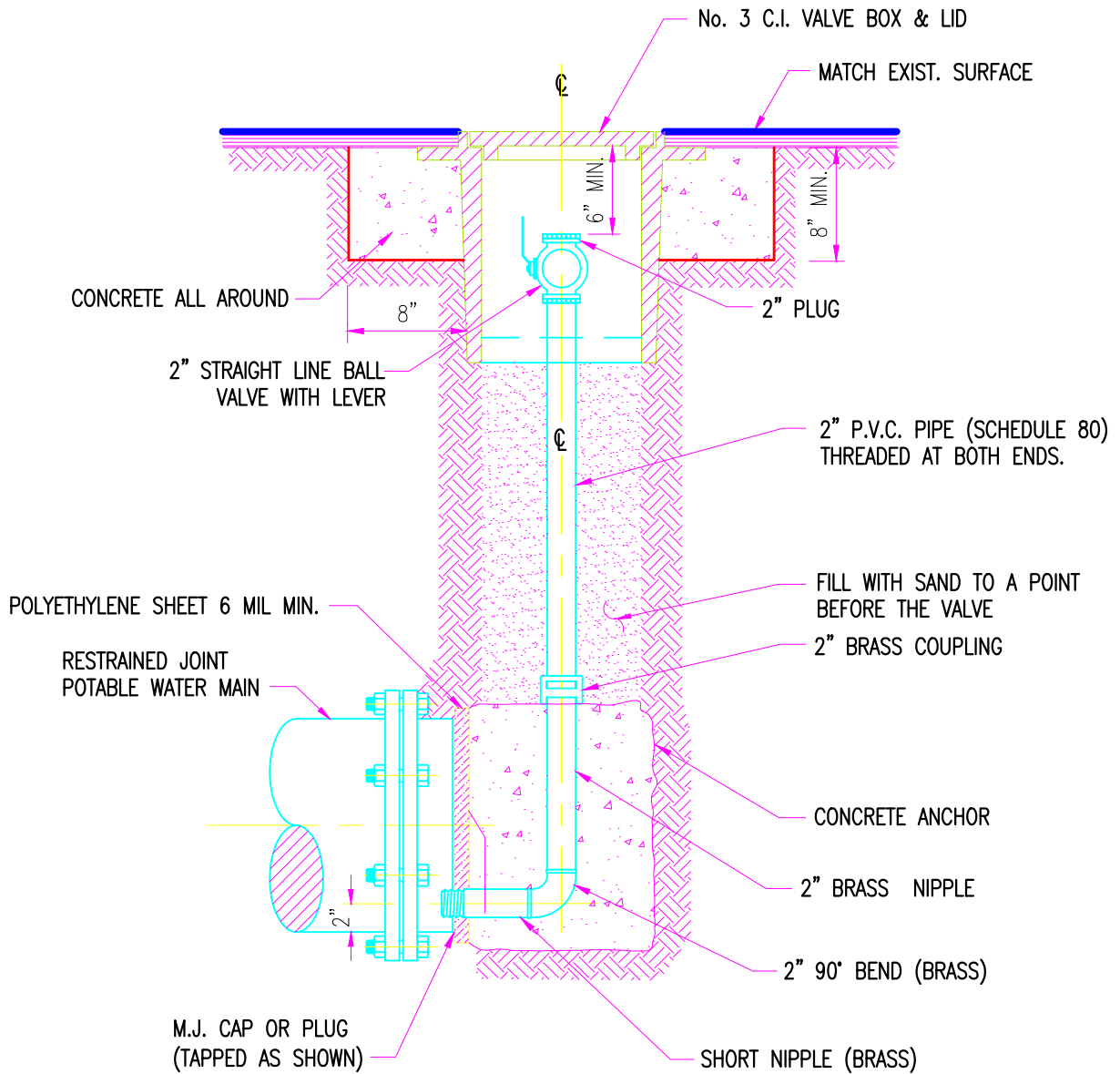

**NOTES:**

1. 2" TAP IN BOTTOM OF PLUG.
2. ALL BRASS TO BE "LEAD FREE".

NO. 3 VALVE BOX & LID	WS 3.11	
CONC. ANCHORS	GS 1.1	
ITEM	CROSS REF.	SPEC. REF.



ISSUE DATE	APPROVED BY
10/06/2009	V.F.C.
10/1/2017 M.K.	D.V.

STANDARD DETAIL  
TYPICAL 2" FLUSHING VALVE  
OUTLET

WS  
1.61  
SHEET 1 OF 1

THE FOLLOWING REQUIREMENTS SHALL APPLY TO ALL CASTINGS  
(OR FABRICATED MATERIALS) CONTAINED HEREIN:

1. SUB-COMPONENTS OF ALL CASTINGS FROM THE SAME SUPPLIER SHALL BE INTERCHANGEABLE.
2. MATING SURFACES OF ALL CASTINGS SHALL BE MACHINED, WITH NO ROCKING PERMITTED.
3. ALL CASTINGS SHALL BE IN ACCORDANCE WITH ASTM-A48, AS MODIFIED HEREIN:
  - A. ARTICLE 10.1.3.1. SHALL NOT APPLY, TIME LIMIT IS 4 HRS. MAXIMUM.
  - B. NOTIFICATION TIME LIMIT IN ARTICLE 16.2 SHALL NOT APPLY.
  - C. SUPPLIER SHALL PROVIDE CERTIFIED TEST RESULTS WITH EACH LOT OF CASTING SHIPPED. CERTIFICATION SHALL IDENTIFY LOT.
  - D. SIGNATURE IN ARTICLE 17.2 SHALL BE REQUIRED. CERTIFICATION SHALL BE SIGNED BY LICENSED PROFESSIONAL ENGINEER, OR EQUIVALENT WHEN IN FOREIGN COUNTRY.
  - E. SUPPLIER SHALL PROVIDE CAST TEST BAR, SUITABLE FOR MACHINING, FOR EACH FOUNDRY LOT OF CASTINGS SHIPPED. TEST BAR SHALL IDENTIFY LOT AND SHALL BE SUITABLE FOR CLASS NO. 35B SPECIMEN.
4. MANUFACTURER'S NAME AND LOCATION (I.E. FOUNDRY AND COUNTRY OF ORIGIN) SHALL BE PERMANENTLY CAST ON THE BOTTOM OF ALL CAST COVERS AND LIDS.
5. SUPPLIER OF FABRICATED ITEMS (I.E. NON-CAST ITEMS) SHALL PERMANENTLY MARK HIS NAME AND DATE OF MANUFACTURE ON MATERIAL, BY WELDING, STAMPING OR OTHER METHOD APPROVED BY THE DEPARTMENT.

I T E M	CROSS REF.	SPEC. REF.

	<u>ISSUE DATE</u>	<u>APPROVED BY</u>	S T A N D A R D   D E T A I L  C A S T I N G   S T A N D A R D S	<b>WS</b> <b>2.05</b> SHEET 1 OF 1
	6/01/2015	J.F.		

5/8" x 3/4" WATER METER (BY DEPARTMENT) WITH 1 1/4" A.S.T. MALE CONNECTION ON EACH END

METER SHALL BE ALIGNED WITH CL OF METER BOX AS SHOWN. (TYP.)

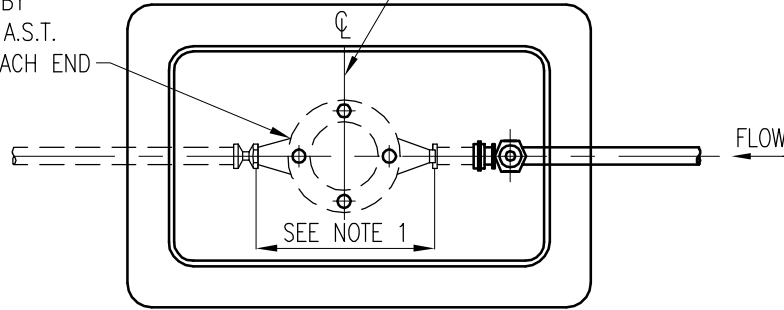

**PLAN**

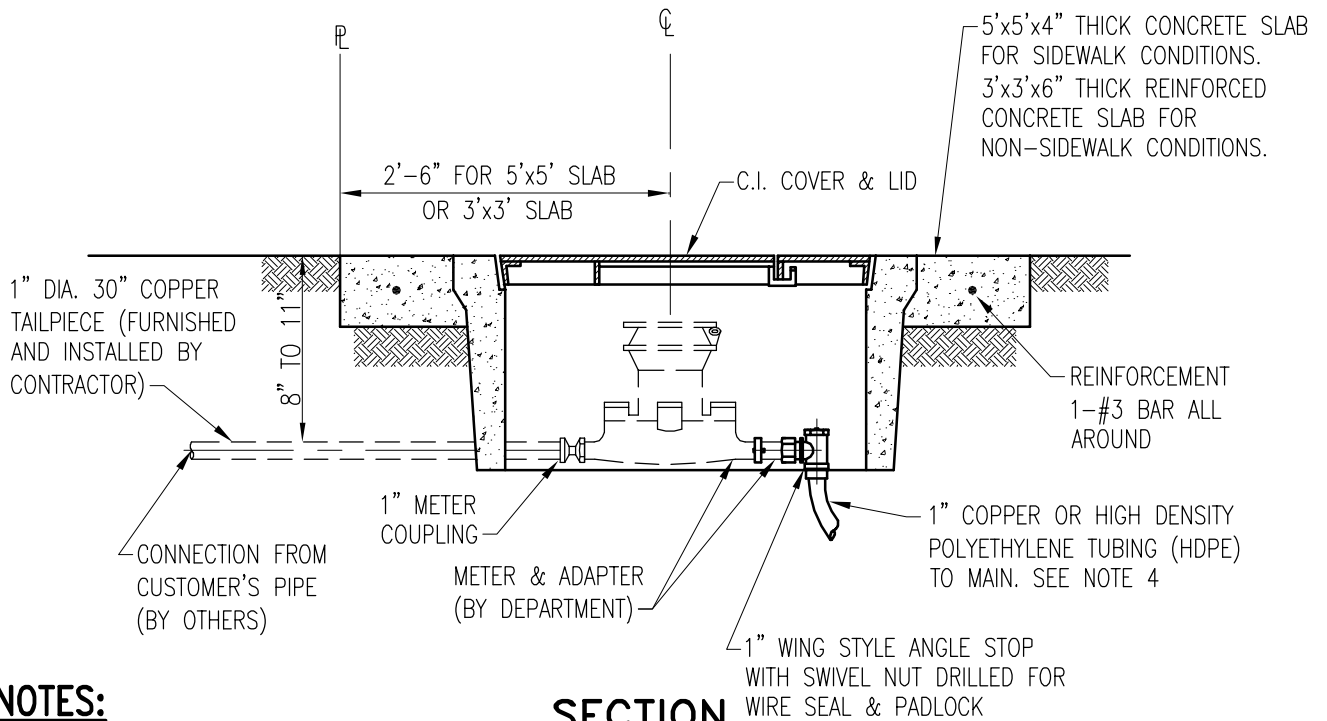

**SECTION**

**NOTES:**

1. METER LAYING LENGTH AS SHOWN:  
10 3/4" (OUTLET TO OUTLET) FOR 5/8" OR 1" METER (11" WITH GASKETS).
2. USE SINGLE METER BOX.
3. CONCRETE SLAB REINFORCEMENT SHALL HAVE 1-#3 BAR ALL AROUND.
4. USE 1" BLUE COLOR HDPE OR 1" COPPER TUBING FOR POTABLE WATER SERVICE. USE ONLY 1" PURPLE COLOR HDPE (NO COPPER ALLOWED) FOR RECLAIMED WATER SERVICE.
5. METERS WILL NOT BE INSTALLED IF THE METER BOX IS IN A DRIVING SURFACE.
6. WHEN USING 1" HDPE SERVICE A TEN GAUGE BLUE (PURPLE FOR RECLAIMED WATER) DIRECT BURY STANDARD COPPER TRACE WIRE IS TO BE TAPED CONTINUOUSLY WITH POLY OR DUCT TAPE TO THE SERVICE FOR LOCATION PURPOSES. WIRE SHALL BE ATTACHED TO WATER MAIN. WIRE MUST EXTEND INTO METER BOX.
7. IF USED FOR RECLAIMED WATER, THE COVER SHALL BE PERMANENTLY EMBOSSED WITH THE WORDING: "RECLAIMED WATER-DO NOT DRINK-NO BEBER-PA BOUE".
8. ALL SPACER TUBES AND TAILPIECES SHALL BE FURNISHED AND INSTALLED BY CONTRACTOR.
9. REPAIRS TO SLAB AND METER ARE PROHIBITED.

1" SERVICE CONNECTION	WS 4.11	
TYPICAL SERVICE PLAN	WS 4.10	
ITEM	CROSS REF.	SPEC. REF.



ISSUE DATE	APPROVED BY
06/01/2008	V.F.C.

STANDARD DETAIL  
SINGLE METER BOX  
INSTALLATION

WS  
2.10  
SHEET 1 OF 3

# PICKHOLE DETAIL

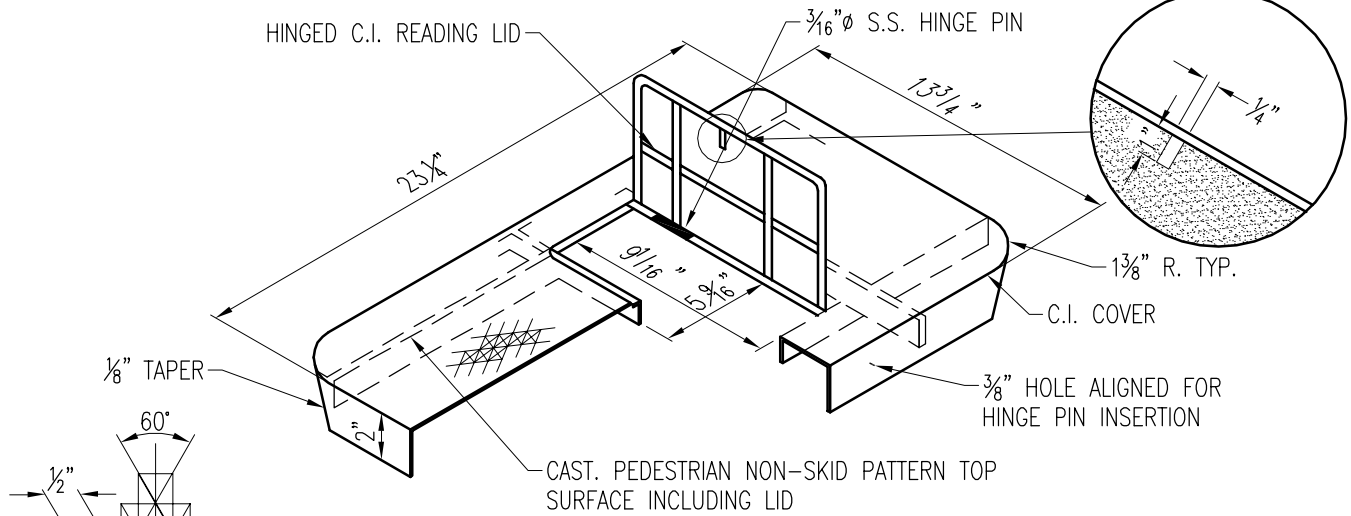

## C.I. COVER WITH HINGER LID

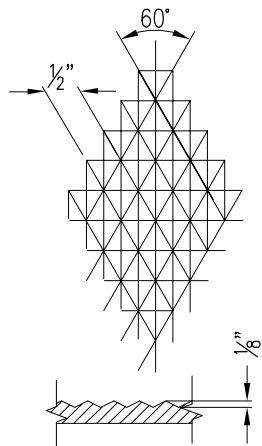

## PATTERN DETAIL

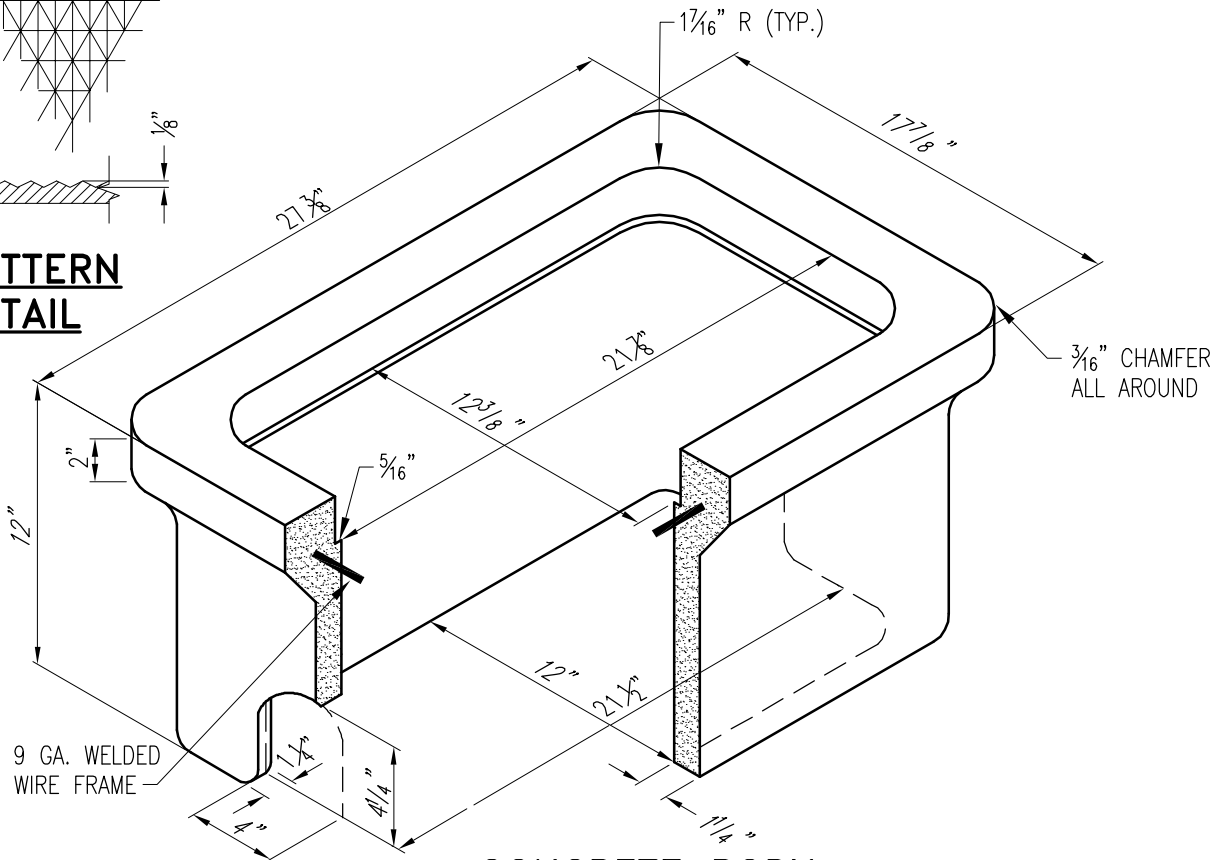

## CONCRETE BODY

### NOTES:

- SOME DIMENSIONS MAY VARY WITH DEPARTMENT APPROVAL.  
LID W.T.= MAX. 53 LBS., MIN. 42 LBS.
- METERS WILL NOT BE INSTALLED IF THE METER BOX IS IN A DRIVING SURFACE.

1" SERVICE CONNECTION	WS 4.11	
TYPICAL SERVICE PLAN	WS 4.10	
ITEM	CROSS REF.	SPEC. REF.

ISSUE DATE	APPROVED BY
06/01/2008	V.F.C.

METER SHALL BE ALIGNED WITH  $\text{C}$   
OF METER BOX AS SHOWN. (TYP.)

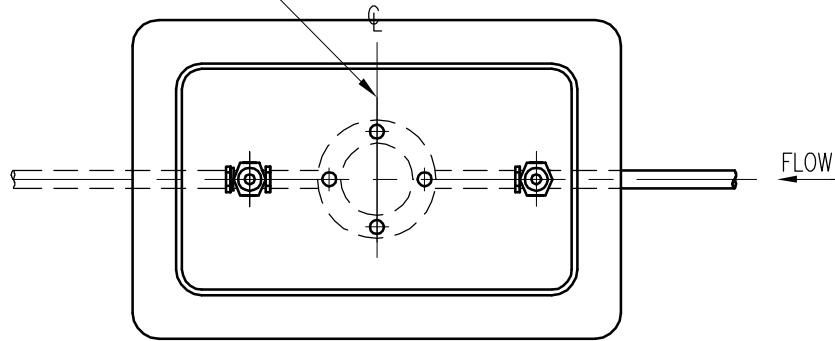

**PLAN**

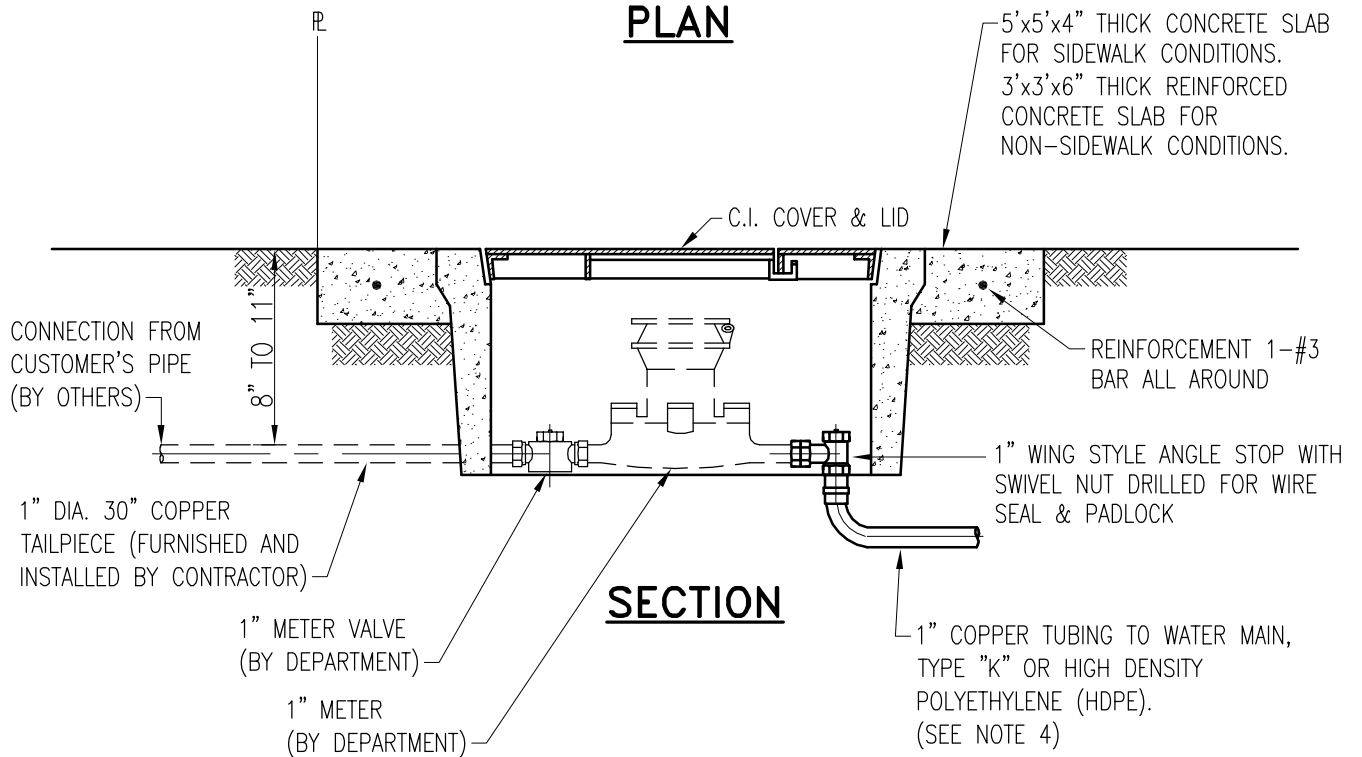

**SECTION**

**NOTES:**

1. SEE SHEET 1 OF 3 FOR DETAILS.
2. USE SINGLE METER BOX.
3. CONCRETE SLAB REINFORCEMENT SHALL HAVE 1-#3 BAR ALL AROUND.
4. USE 1" BLUE COLOR HDPE OR 1" COPPER TUBING FOR POTABLE WATER SERVICE. USE ONLY 1" PURPLE COLOR HDPE (NO COPPER ALLOWED) FOR RECLAIMED WATER SERVICE.
5. METERS WILL NOT BE INSTALLED IF THE METER BOX IS IN A DRIVING SURFACE.
6. WHEN USING 1" HDPE SERVICE, A TEN GAUGE BLUE (PURPLE FOR RECLAIMED WATER) DIRECT BURY STANDARD COPPER TRACE WIRE IS TO BE TAPED CONTINUOUSLY WITH POLY OR DUCT TAPE TO THE SERVICE FOR LOCATION PURPOSES. WIRE MUST BE ATTACHED TO WATER MAIN AND EXTEND INTO WATER METER.
7. ALL SPACER TUBES AND TAILPIECES SHALL BE FURNISHED AND INSTALLED BY CONTRACTOR.
8. REPAIRS TO SLAB AND METER ARE PROHIBITED.

1" SERVICE CONNECTION	WS 4.11	
TYPICAL SERVICE PLAN	WS 4.10	
I T E M	CROSS REF.	SPEC. REF.



ISSUE DATE	APPROVED BY
06/01/2008	V.F.C.

STANDARD DETAIL  
SINGLE METER BOX  
FOR  
MULTI-STORY BUILDING

WS  
2.10  
SHEET 3 OF 3

**PICKHOLE DETAIL**

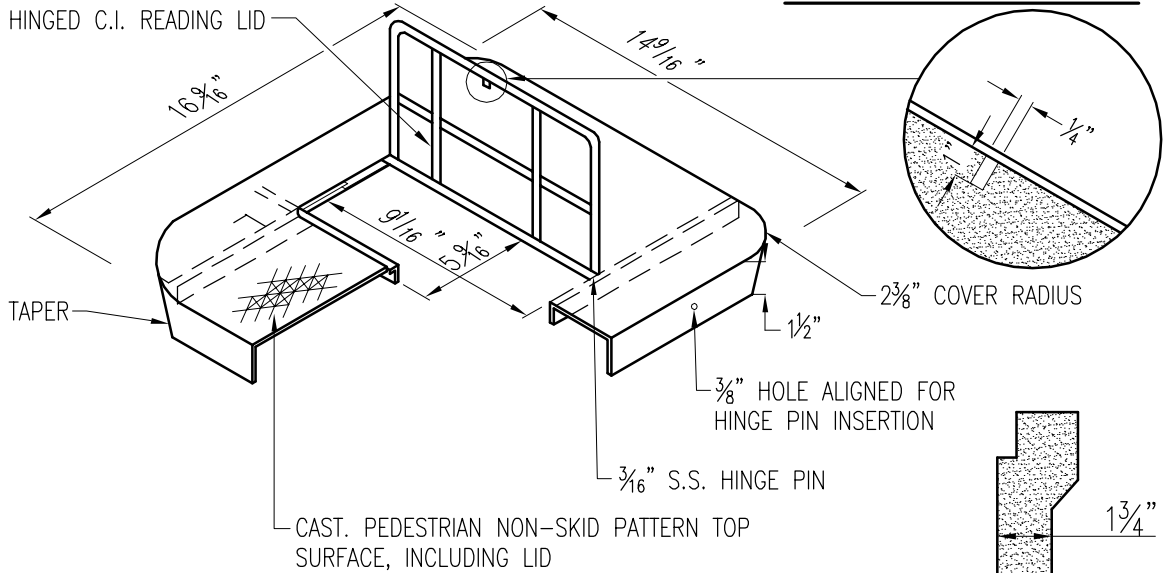

**C.I. COVER WITH HINGED LID**

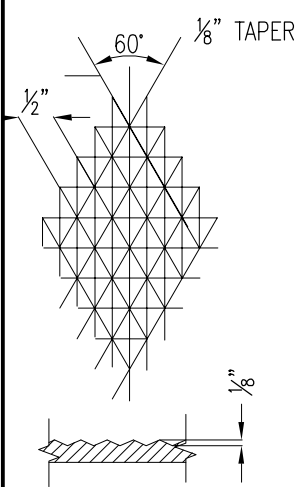

**PATTERN DETAIL**

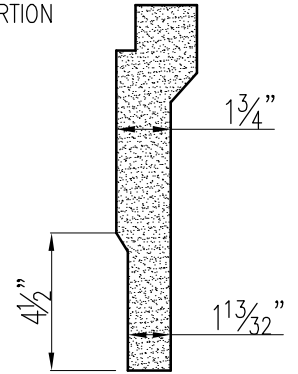

**DETAIL "A"**

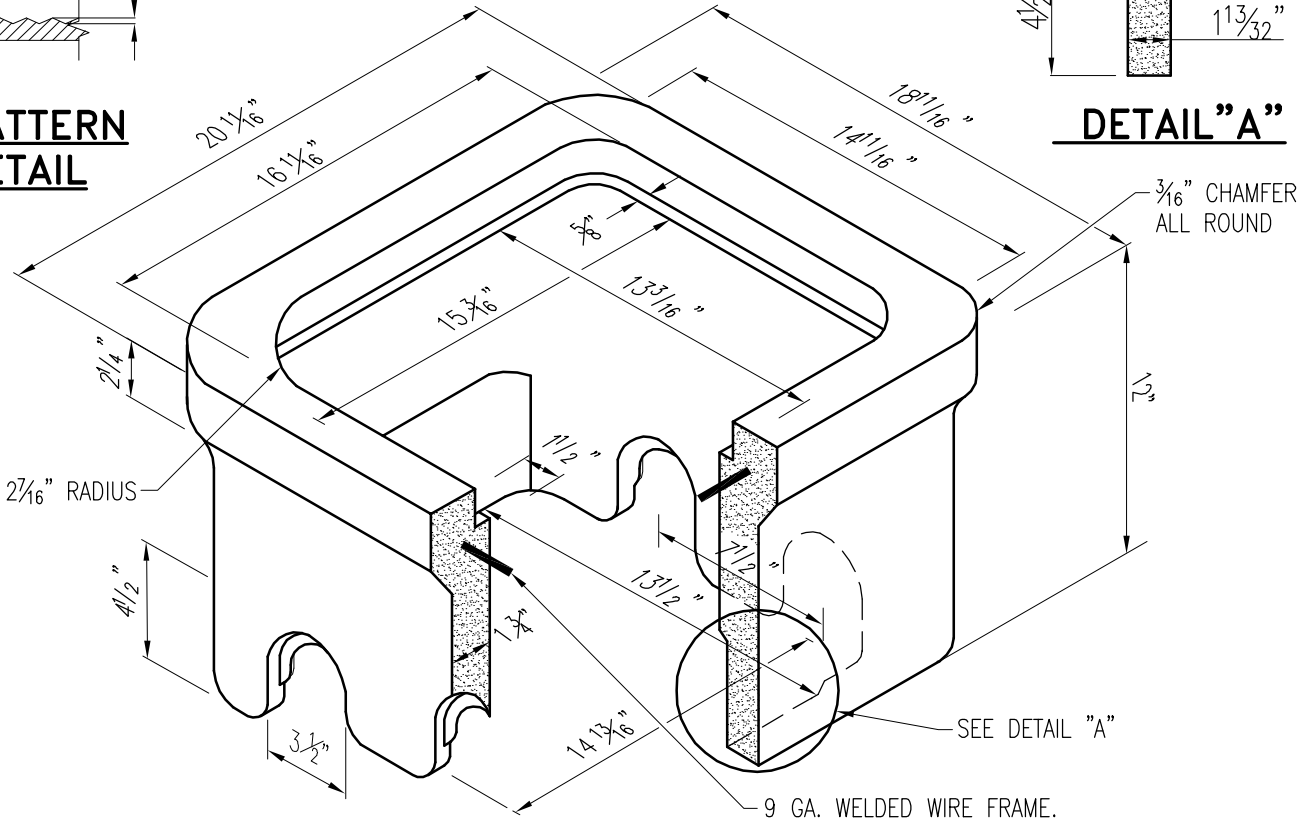

**CONCRETE BODY**

**NOTE:**

- SOME DIMENSIONS MAY VARY WITH DEPARTMENT APPROVAL.  
LID W.T.= MAX. 33 LBS., MIN. 26 LBS.
- METERS WILL NOT BE INSTALLED IF THE METER BOX IS IN A DRIVING SURFACE.

ITEM	CROSS REF.	SPEC. REF.



ISSUE DATE	APPROVED BY
11/01/2006	V.F.C.

STANDARD DETAIL  
DUAL METER BOX  
INSTALLATION

WS  
2.12  
SHEET 1 OF 2

(2) 5/8" x 3/4" WATER METERS (BY DEPARTMENT) WITH 3/4" A.S.T. MALE CONNECTION ON EACH END

METER SHALL BE ALIGNED WITH C OF METER BOX AS SHOWN. (TYP.)

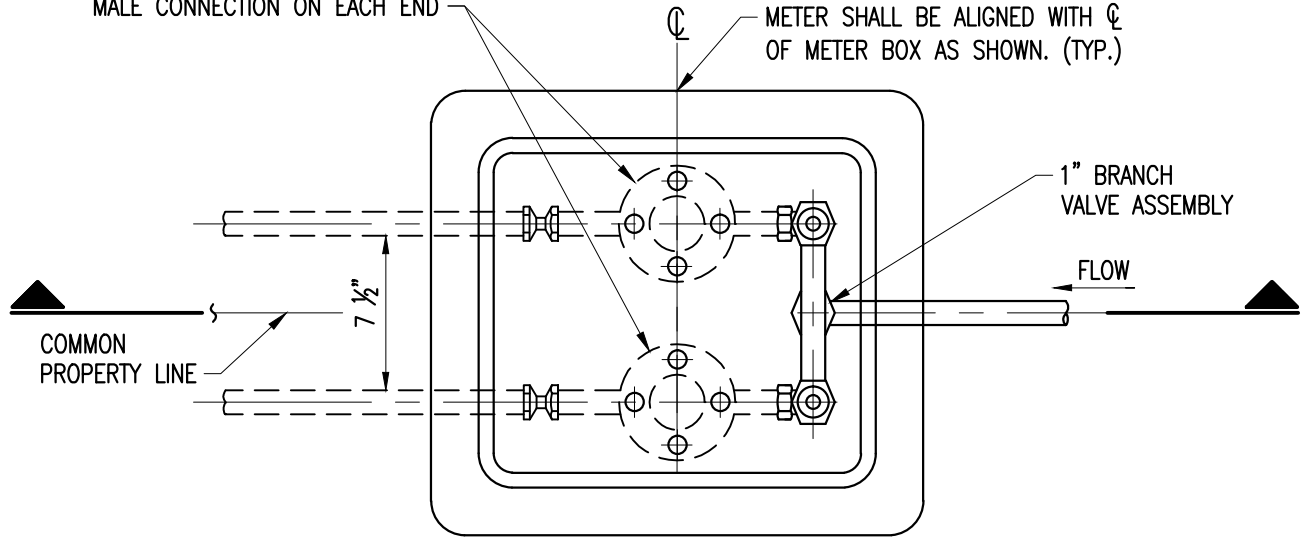

**PLAN**

METER SHALL BE ALIGNED WITH C OF METER BOX AS SHOWN. (TYP.)

5'x5'x4" THICK CONCRETE SLAB FOR SIDEWALK CONDITIONS. 3'x3'x6" THICK REINFORCED CONCRETE SLAB FOR NON-SIDEWALK CONDITIONS.

2'-6" FOR 5'x5' SLAB  
1'-6" FOR 3'x3' SLAB

C.I. COVER & LID

REINFORCEMENT  
1-#3 BAR  
ALL AROUND

30" COPPER TAILPIECE  
(FURNISHED AND INSTALLED  
BY CONTRACTOR)

8"-11"

CONNECTION FROM  
CUSTOMER'S PIPE  
(BY OTHERS)

3/4" METER  
COUPLING

1" WING STYLE ANGLE STOP  
WITH SWIVEL NUT DRILLED FOR  
WIRE SEAL & PADLOCK

**SECTION**

1" COPPER PIPE, TYPE "K"  
OR HDPE

**NOTES:**

1. USE DUAL METER BOX.
2. CONCRETE SLAB REINFORCEMENT SHALL BE ONE No. 3 BAR ALL ROUND.
3. FOR SIDEWALK CONDITIONS, METER BOX SHALL BE INSTALLED IN A SINGLE CONCRETE SIDEWALK FLAG.
4. METERS WILL NOT BE INSTALLED IF THE METER BOX IS IN A DRIVING SURFACE.
5. REPAIRS TO CONCRETE SLAB AND METER BOX ARE PROHIBITED.
6. ALL SPACER TUBES AND TAILPIECES SHALL BE FURNISHED AND INSTALLED BY CONTRACTOR.

1" SERVICE CONNECTION	WS 4.11	
TYPICAL SERVICE PLAN	WS 4.10	
ITEM	CROSS REF.	SPEC. REF.



ISSUE DATE	APPROVED BY
10/29/2010	V.F.C.

STANDARD DETAIL  
DUAL 5/8" METER INSTALLATION  
FOR TYPICAL 3/4" DOMESTIC  
SERVICE LINES

WS  
2.12  
SHEET 2 OF 2

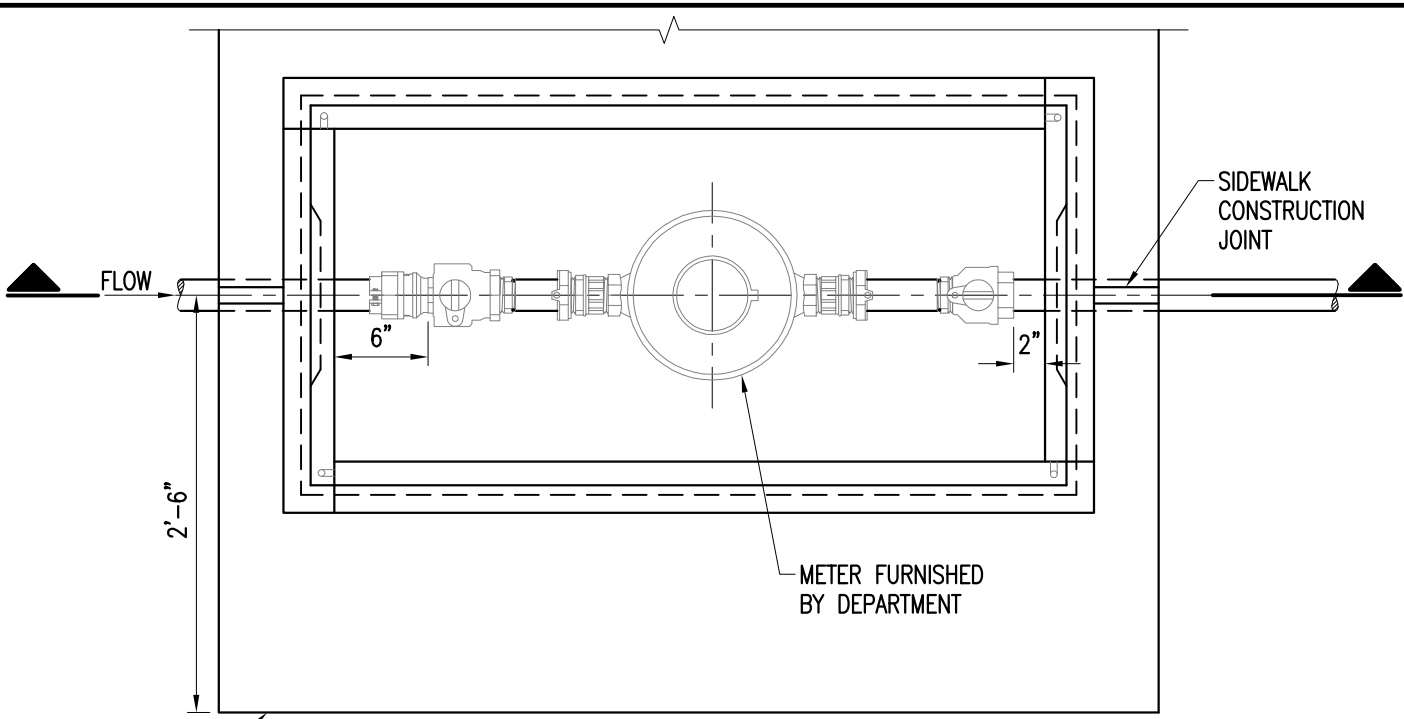

**PLAN**

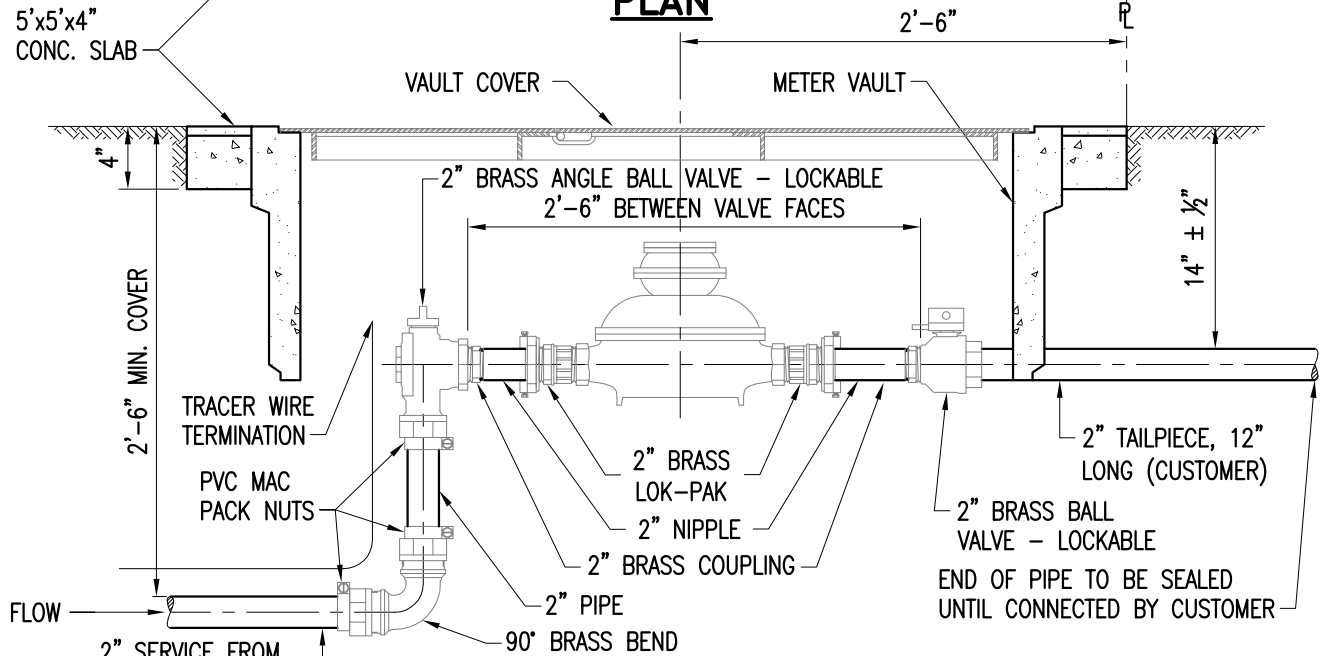

**SECTION**

**NOTES:**

1. USE 2'x4' METER VAULT.
2. METER BOX TO BE IN 5'x5'x4" THICK CONCRETE SLAB WITH 6x6-W1.4xW1.4 W.W.M.
3. A TEN GAUGE BLUE (PURPLE FOR RECLAIMED WATER) DIRECT BURY STRANDED COPPER TRACER WIRE TO BE TAPED CONTINUOUSLY WITH POLY OR DUCT TAPE TO THE SERVICE FOR LOCATION PURPOSES. WIRE MUST BE ATTACHED TO WATER MAIN AND EXTEND INTO THE WATER METER BOX.
4. USE 2" BLUE COLOR HDPE FOR POTABLE WATER SERVICE. USE 2" PURPLE COLOR HDPE FOR RECLAIMED WATER SERVICE.
5. METERS WILL NOT BE INSTALLED IF THE METER BOX IS LOCATED ON A DRIVING SURFACE.
6. METER BOX SHALL BE INSTALLED BETWEEN TWO SEPARATE FLAGS OF CONCRETE.
7. ALL BRASS COMPONENTS SHALL BE MARKED "NL" MEETING THE S3874 AMENDMENT TO THE SAFE DRINKING WATER ACT.

TYPICAL SERVICE PLAN	WS 4.10	
2'x4' METER VAULT	WS 2.17	
ITEM	CROSS REF.	SPEC. REF.



ISSUE DATE	APPROVED BY
05/31/2013	E.A.V.

STANDARD DETAIL  
**TYPICAL 2" SERVICE  
 INSTALLATION WITH A 2" METER**

**WS  
 2.16**  
 SHEET 1 OF 4



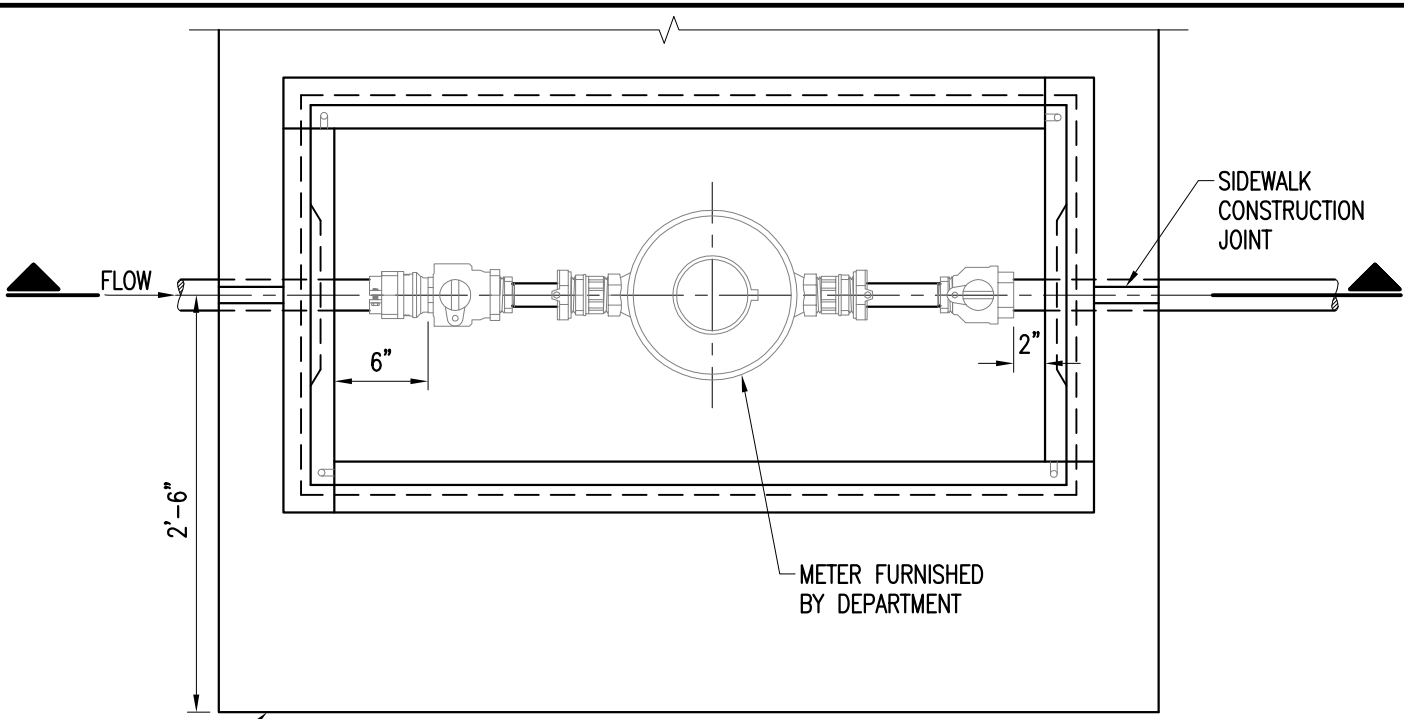

**PLAN**

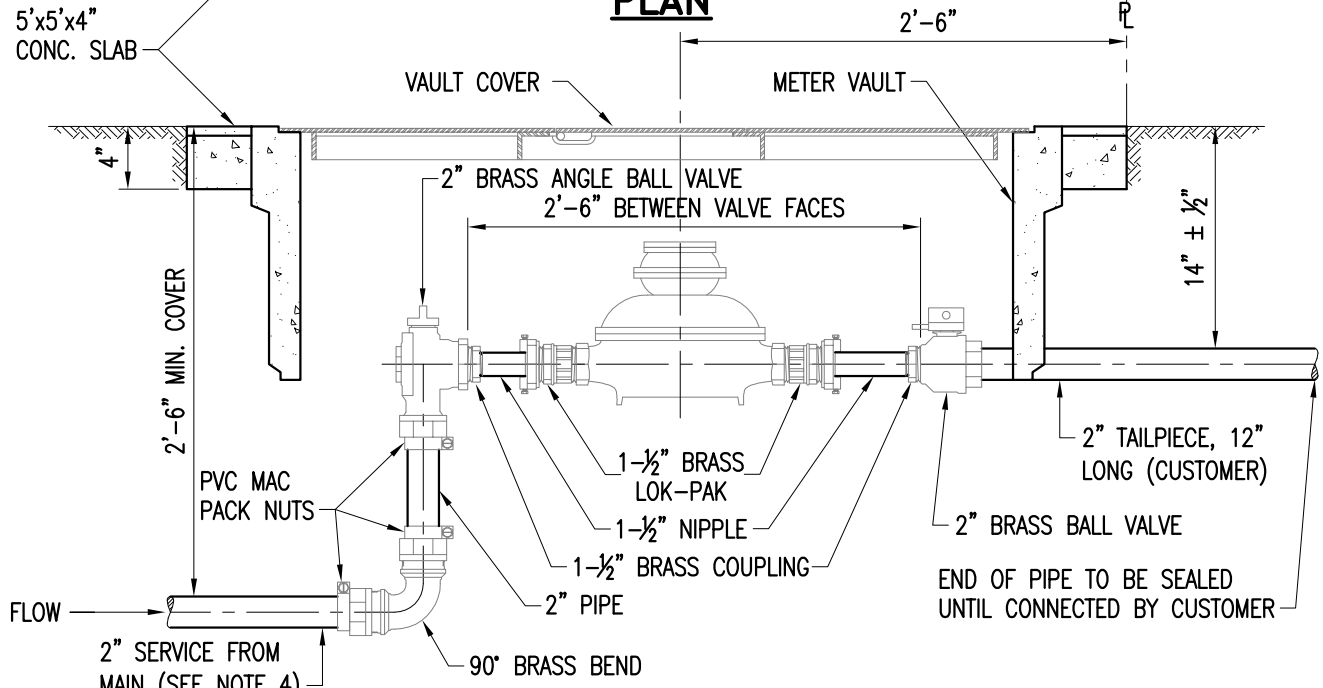

**SECTION**

**NOTES:**

1. USE 2'x4' METER VAULT.
2. METER BOX TO BE IN 5'x5'x4" THICK CONCRETE SLAB WITH 6x6-W1.4xW1.4 W.W.M.
3. A TEN GAUGE DIRECT BURY STRANDED COPPER TRACER WIRE TO BE TAPED CONTINUOUSLY WITH POLY OR DUCT TAPE TO THE SERVICE FOR LOCATION PURPOSES. WIRE MUST BE ATTACHED TO RECLAIMED WATER MAIN AND EXTEND INTO THE METER BOX.
4. USE 2" BLUE COLOR HDPE FOR POTABLE WATER SERVICE. USE 2" PURPLE COLOR HDPE FOR RECLAIMED WATER SERVICE.
5. METERS WILL NOT BE INSTALLED IF THE METER BOX IS IN A DRIVING SURFACE.
6. FOR SIDEWALK CONDITIONS, METER BOX SHALL BE INSTALLED IN A SINGLE CONCRETE SIDEWALK FLAG.
7. ALL BRASS COMPONENTS SHALL BE MARKED "NL" MEETING THE S3874 AMENDMENT TO THE SAFE DRINKING WATER ACT.

TYPICAL SERVICE PLAN	WS4.10	
2'x4' METER VAULT	WS2.17	
ITEM	CROSS REF.	SPEC. REF.



ISSUE DATE	APPROVED BY
5/31/2013	E.A.V.

STANDARD DETAIL  
**TYPICAL 2" SERVICE  
 INSTALLATION WITH A 1-1/2" METER**

**WS  
 2.16**  
 SHEET 2 OF 4

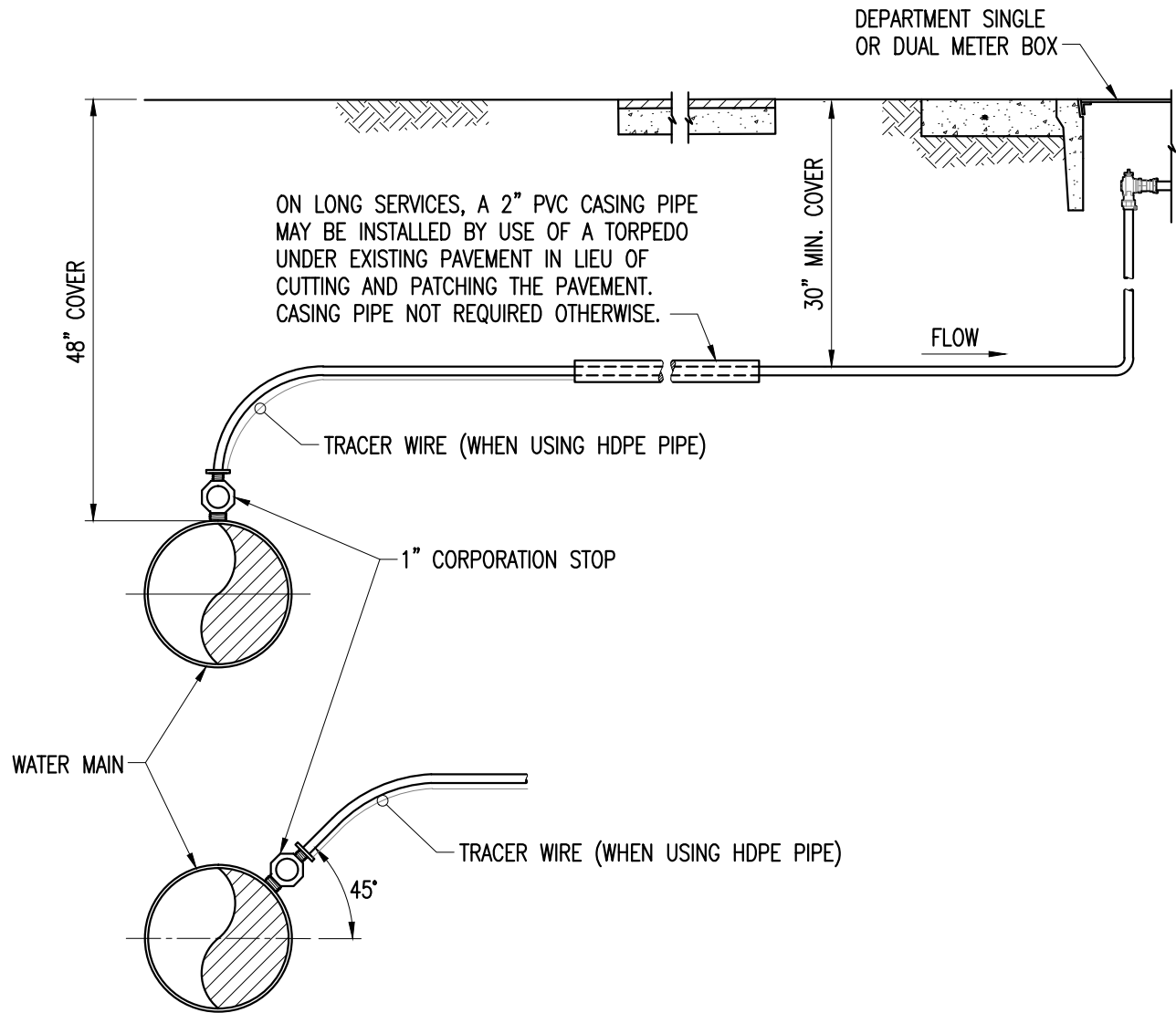

**NOTES:**

1. CONTRACTOR HAS THE OPTION OF TAPPING AT 45°.
2. METERS WILL NOT BE INSTALLED IF THE METER BOX IS LOCATED ON A DRIVING SURFACE.
3. PROVIDE 36" MIN. COVER FOR SERVICES INSTALLED WITHIN ARTERIAL ROADS (INCLUDING ALL SECTION LINE AND HALF-SECTION LINE ROADS).
4. INSTALL TAPPING SADDLE FOR: THICKNESS CLASS D.I. MAINS 4" & SMALLER, PRESSURE CLASS D.I. WATER MAINS 6" & SMALLER, OR WHEN MAIN IS PVC, HDPE OR AC PIPE.
5. WHEN MAIN IS SHALLOWER THAN 48", A 1/8" OR 1/4" BEND MUST BE USED.
6. WHEN USING HDPE SERVICE PIPE, A TEN GAUGE BLUE TRACER WIRE TO BE TAPED TO THE PIPE EVERY 2 FT. WITH POLY OR DUCT TAPE. TRACER WIRE TO BE MECHANICALLY FASTENED TO THE MAIN WHEN A METAL WATER MAIN IS USED.
7. USE SERVICE SADDLE AND TAPPING SLEEVE FOR PVC RECLAIMED WATER MAIN.

TYPICAL SERVICE PLAN	WS. 4.10	
ITEM	CROSS REF.	SPEC. REF.



ISSUE DATE	APPROVED BY
1/3/2011	V.F.C.

STANDARD DETAIL  
**TYPICAL 1" SERVICE CONNECTION**  
 (COPPER OR HDPE)

**WS**  
**2.16**  
 SHEET 3 OF 4

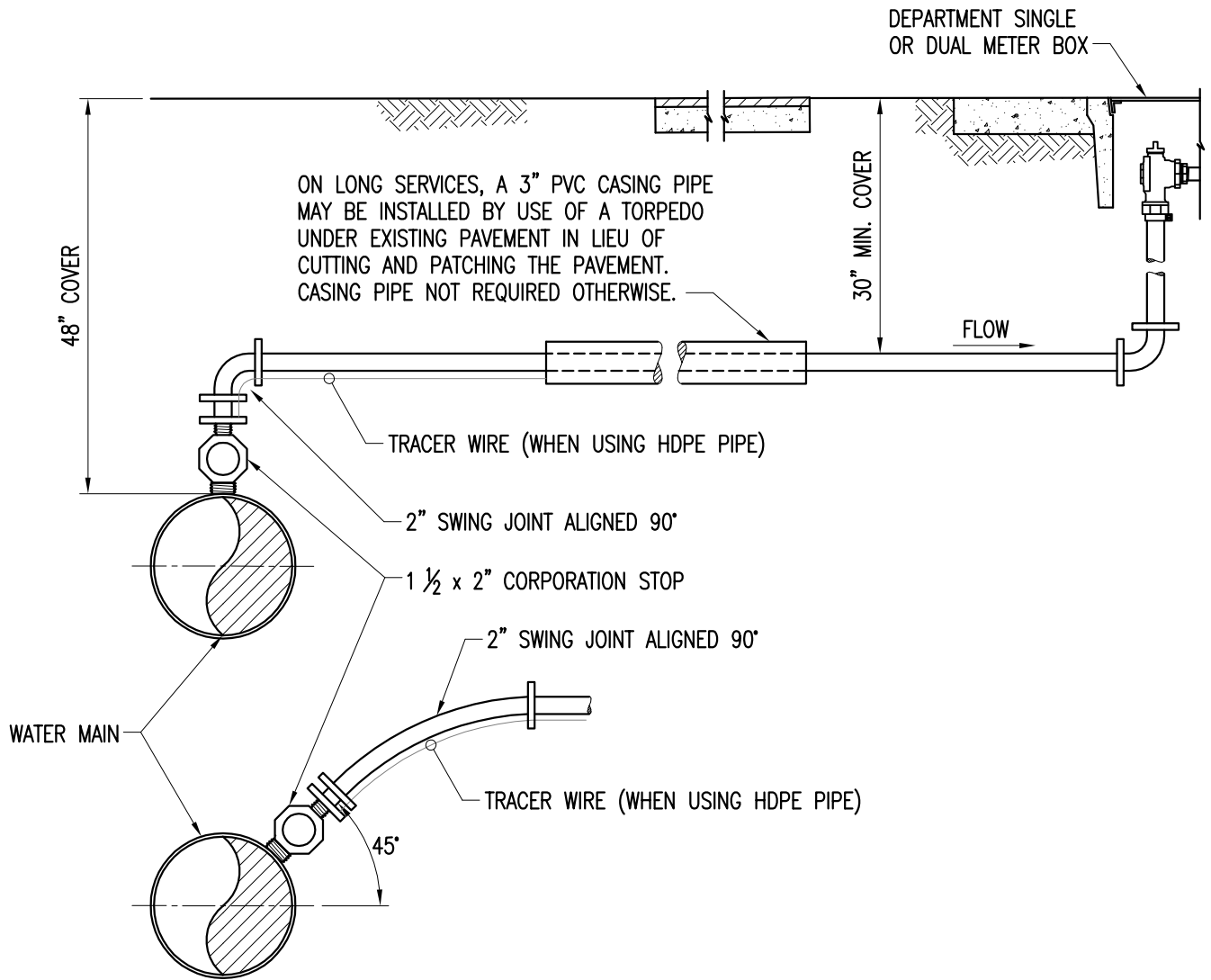

**NOTES:**

1. CONTRACTOR HAS THE OPTION OF TAPPING AT 45°.
2. METERS WILL NOT BE INSTALLED IF THE METER BOX IS LOCATED ON A DRIVING SURFACE.
3. PROVIDE 36" MIN. COVER FOR SERVICES INSTALLED WITHIN ARTERIAL ROADS (INCLUDING ALL SECTION LINE AND HALF-SECTION LINE ROADS).
4. INSTALL TAPPING SADDLE FOR: THICKNESS CLASS D.I. MAINS 4" & SMALLER, PRESSURE CLASS D.I. WATER MAINS 8" & SMALLER, OR WHEN MAIN IS PVC, HDPE OR AC PIPE.
5. WHEN MAIN IS SHALLOWER THAN 48", A 1/8 OR 1/4 BEND MUST BE USED.
6. WHEN USING HDPE SERVICE PIPE, A TEN GAUGE BLUE TRACER WIRE TO BE TAPED TO THE PIPE EVERY 2 FT. WITH POLY OR DUCT TAPE. TRACER WIRE TO BE MECHANICALLY FASTENED TO THE MAIN WHEN A METAL WATER MAIN IS USED.
7. USE SERVICE SADDLE AND TAPPING SLEEVE FOR PVC RECLAIMED WATER MAIN.

DUAL METER BOX	WS 2.12	
SINGLE METER BOX	WS 2.10	3.02
ITEM	CROSS REF.	SPEC. REF.



ISSUE DATE	APPROVED BY
12/16/2009	V.F.C.

STANDARD DETAIL  
 TYPICAL 2" SERVICE CONNECTION (HDPE)

WS  
 2.16  
 SHEET 4 OF 4

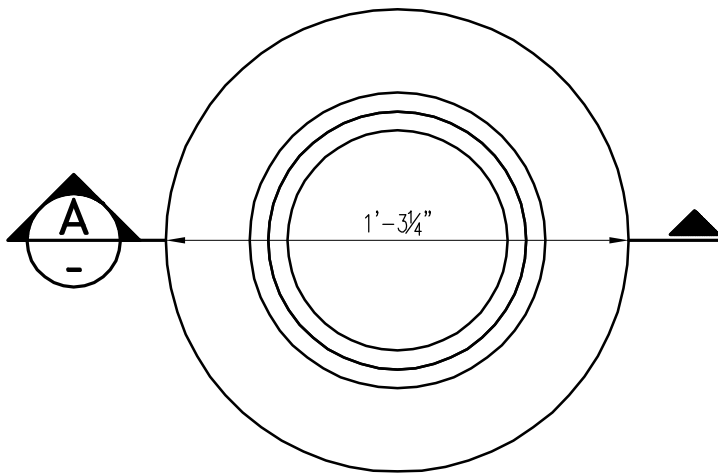

**BOX PLAN**  
N.T.S.

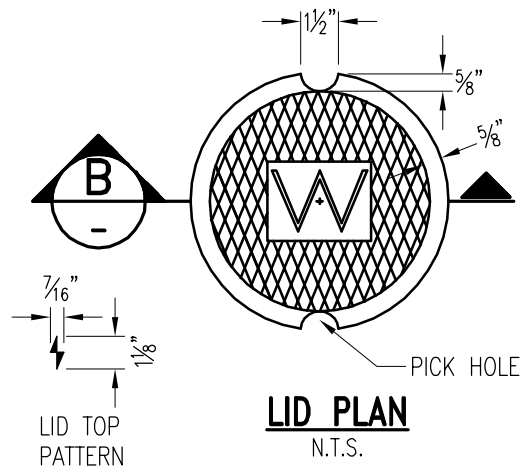

**LID PLAN**  
N.T.S.

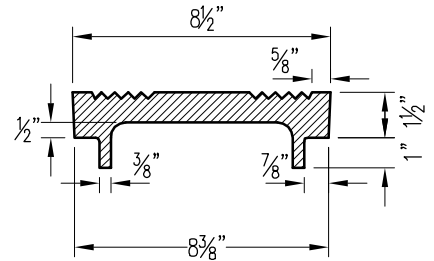

**SECTION B**  
N.T.S.

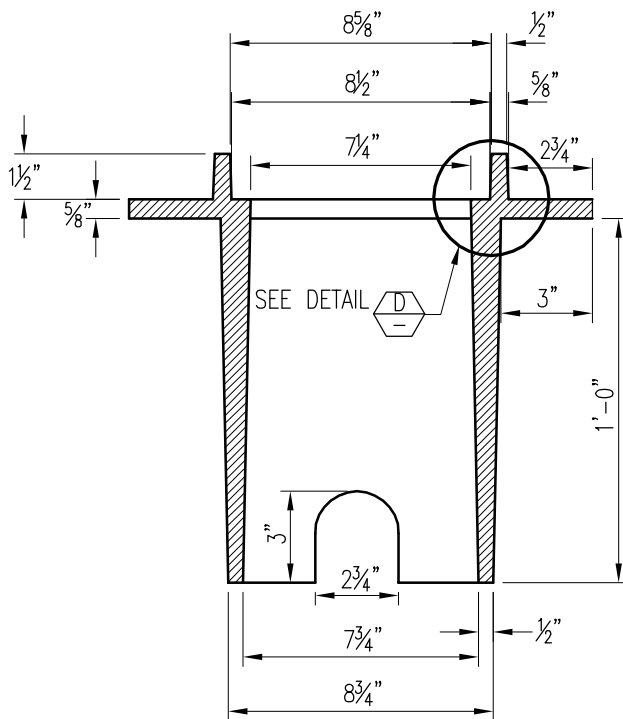

**SECTION A**  
N.T.S.

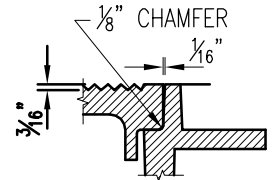

**DETAIL D**  
N.T.S.

**NOTES:**

1. FOUNDRY AND LOCATION SHALL BE CAST ON BOTTOM OF LID. (SEE WS 2.05)
2. MACHINE FINISH BOTTOM OF COVER AND SEAT OF FRAME.
3. ALL DIMENSIONS ARE NET CASTING, NOT PATTERN.
4. IF USED FOR RECLAIMED WATER, THE CAST IRON LID AND BOX ARE TO BE COLORED PURPLE PANTONE 522C, AND THE LETTER "W" REPLACED WITH "R".

ITEM	CROSS REF.	SPEC. REF.

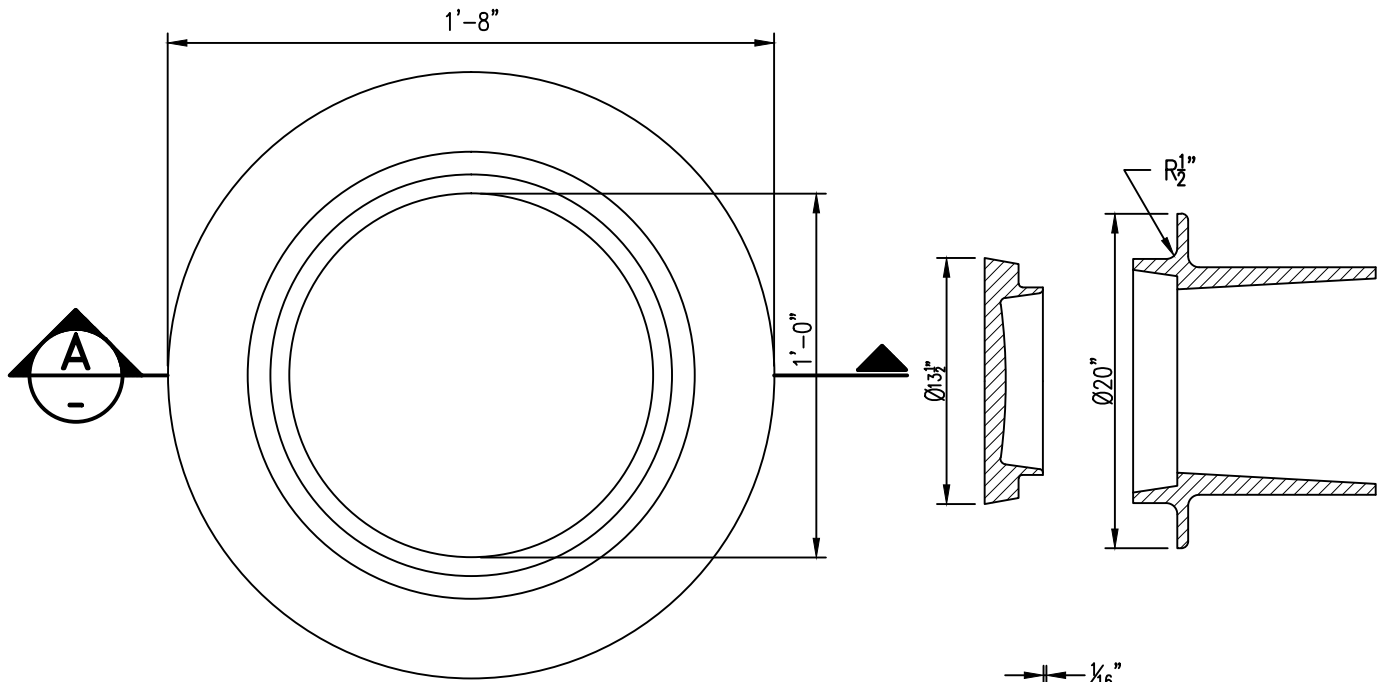

**PLAN VIEW**  
N.T.S.

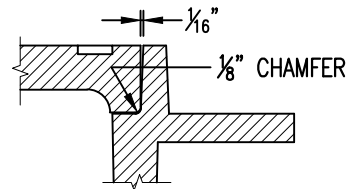

**LID DETAIL**  
N.T.S.

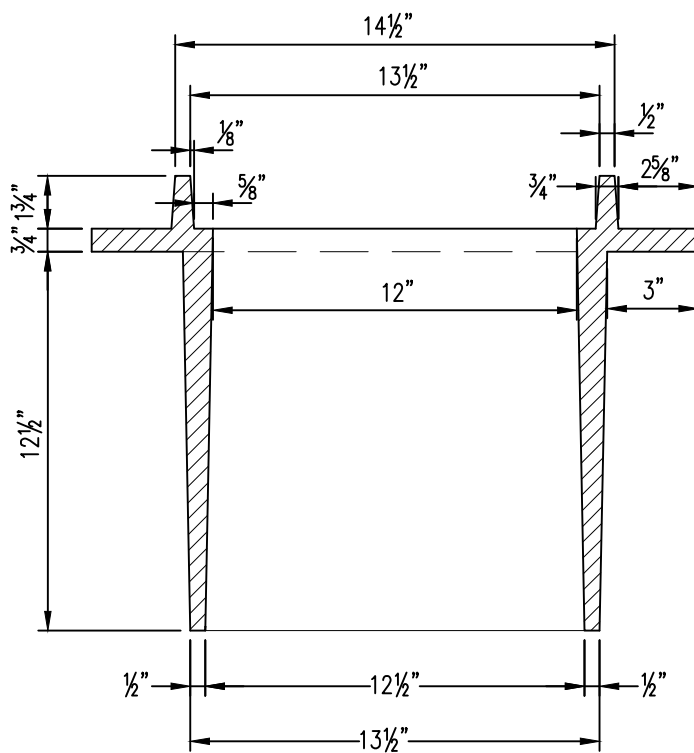

**SECTION A-A**  
N.T.S.

**NOTES:**

1. FOUNDRY AND LOCATION SHALL BE CAST ON BOTTOM OF THE LID. (SEE WS 2.05)
2. ALL DIMENSIONS ARE NET CASTING, NOT PATTERN.
3. IF USED FOR RECLAIMED WATER, THE CAST IRON LID AND BOX ARE TO BE COLORED PURPLE PANTONE 522C, AND THE LETTER "W" REPLACED WITH "R".
4. MIN. WEIGHTS  
RING: 135 LBS.  
COVER: 37 LBS

ITEM	CROSS REF.	SPEC. REF.



ISSUE DATE	APPROVED BY
6/1/2015	J.F.

STANDARD DETAIL  
No. 3 C.I. VALVE BOX

WS  
3.11  
SHEET 1 OF 2

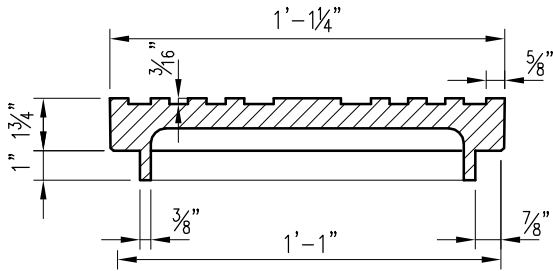

**SECTION VIEW**

N.T.S.

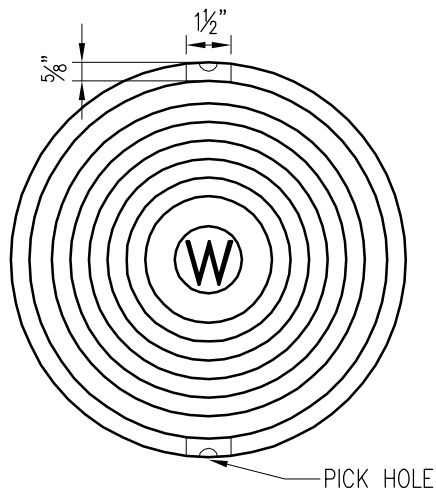

**PLAN VIEW**

N.T.S.

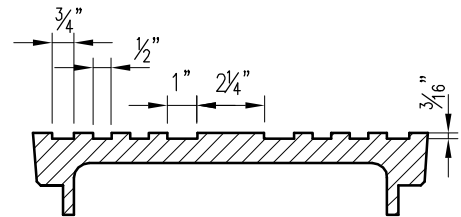

**DETAIL OF LID TOP**

N.T.S.

**NOTES:**

1. MACHINE FINISH BOTTOM OF COVER AND SEAT OF FRAME.
2. ALL DIMENSIONS ARE NET CASTING, NOT PATTERN.
3. FOUNDRY AND LOCATION SHALL BE CAST ON BOTTOM OF THE LID. (SEE WS 2.05)
4. IF USED FOR RECLAIMED WATER, THE CAST IRON LID IS TO BE COLORED PURPLE PANTONE 522C, AND THE LETTER "W" REPLACED WITH "R".

I T E M	CROSS REF.	SPEC. REF.



ISSUE DATE	APPROVED BY
06/01/2008	V.F.C.

S T A N D A R D   D E T A I L

No. 3 C.I. LID

WS  
3.11  
SHEET 2 OF 2

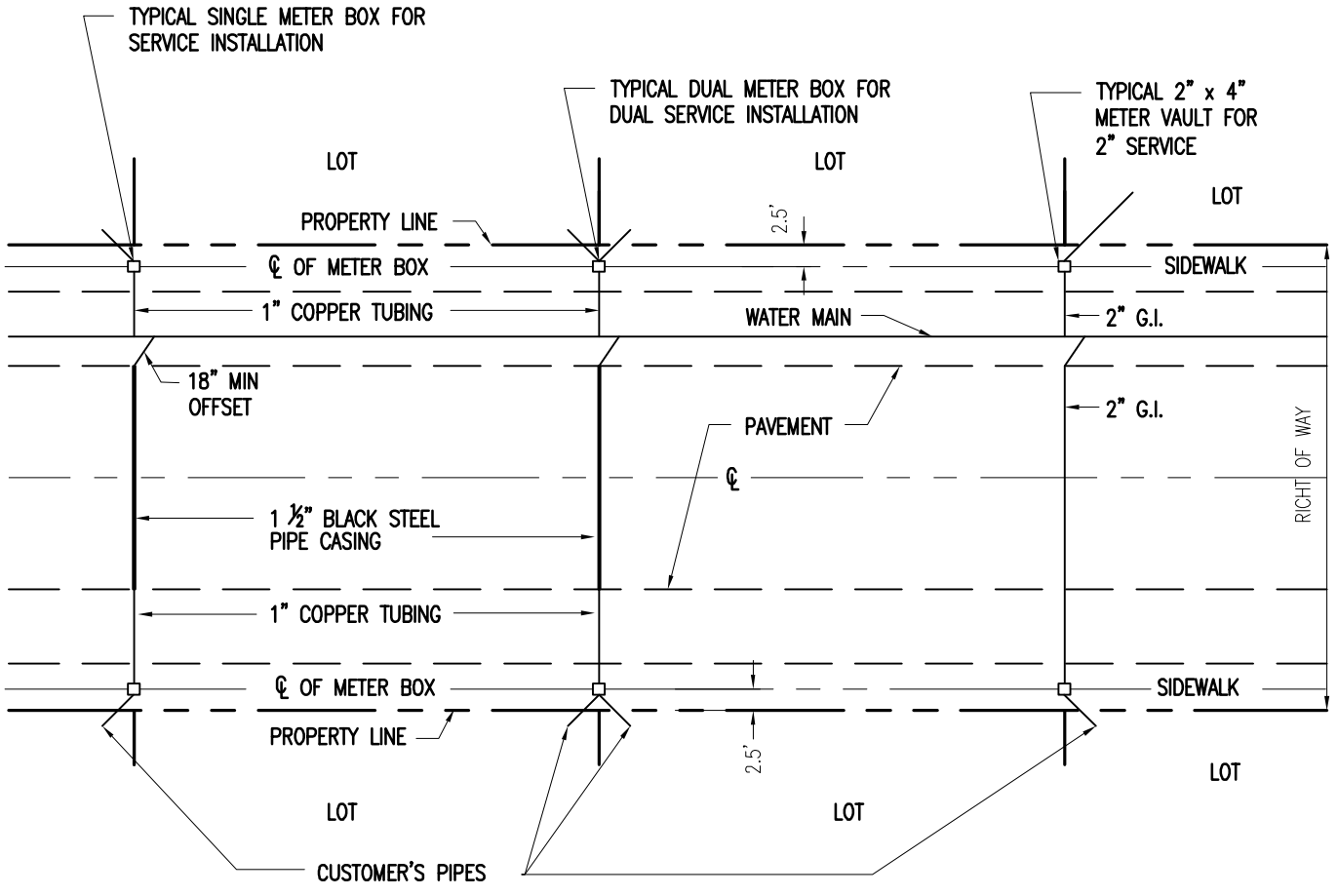

**PLAN**

NOTE: METERS WILL NOT BE INSTALLED IF THE METER BOX IS IN A DRIVING SURFACE.

ITEM	CROSS REF.	SPEC. REF.



ISSUE DATE	APPROVED BY
11/01/2006	V.E.F.

STANDARD DETAIL  
TYPICAL SERVICE PLAN

WS  
4.10  
SHEET 1 OF 1

D.I. TAPPING SLEEVE (NOT REQ'D. ON CONCRETE MAINS WHERE SPECIAL TAPPING FLANGE OUTLETS ARE EXISTING)

THRUST BLOCK REQUIRED

VARIABLE

EXISTING MAIN

TAPPING VALVE  
NON-RISING STEM

D.I. NIPPLE

D.I. 90° M.J.  
REST. BEND

D.I. NIPPLE

VARIABLE

CONCRETE TO  
UNDISTURBED  
GROUND

D.I. M.J. TEE

PROPOSED C.I.  
OR D.I. MAIN

**PLAN**

TAPPING VALVE  
NON-RISING STEM

EXISTING MAIN

ANCHOR NOT SHOWN

D.I. NIPPLE

D.I. M.J. TEE

4" MIN.  
(VARIES)

PROPOSED C.I.  
OR D.I. MAIN

**SECTION**

**NOTE:**

1. ALL PIPE AND FITTINGS TO BE RESTRAINED.

ITEM	CROSS REF.	SPEC. REF.



WATER & SEWER DEPARTMENT

ISSUE DATE

06/20/2008

APPROVED BY

V.F.C.

STANDARD DETAIL

TYPICAL CONNECTION  
TO EXISTING MAIN

WS

4.12

SHEET 1 OF 2



D.I. TAPPING SLEEVE (NOT REQ. ON CONCRETE MAINS WHERE SPECIAL TAPPING FLANGE OUTLETS ARE EXISTING)

THRUST BLOCK REQUIRED

VARIABLE

EXISTING MAIN

TAPPING VALVE  
NON-RISING STEM

D.I. NIPPLE

D.I. 90° M.J.  
REST. BEND

D.I. BEND AS REQUIRED  
ANCHOR NOT SHOWN

D.I. NIPPLE

VARIABLE

CONCRETE TO  
UNDISTURBED  
GROUND

D.I. M.J. TEE

PROPOSED C.I.  
OR D.I. MAIN

## PLAN

TAPPING VALVE  
NON-RISING STEM

D.I. BEND  
AS REQUIRED

D.I. M.J. TEE

4" MIN.  
(VARIES)

EXISTING MAIN

ANCHOR NOT SHOWN

D.I. NIPPLE

PROPOSED C.I.  
OR D.I. MAIN

## SECTION

### NOTE:

1. ALL PIPE AND FITTINGS TO BE RESTRAINED.

ITEM	CROSS REF.	SPEC. REF.

ISSUE DATE

06/20/2008

APPROVED BY

V.F.C.

STANDARD DETAIL

TYPICAL CONNECTION  
TO EXISTING MAIN

WS  
4.12  
SHEET 2 OF 2

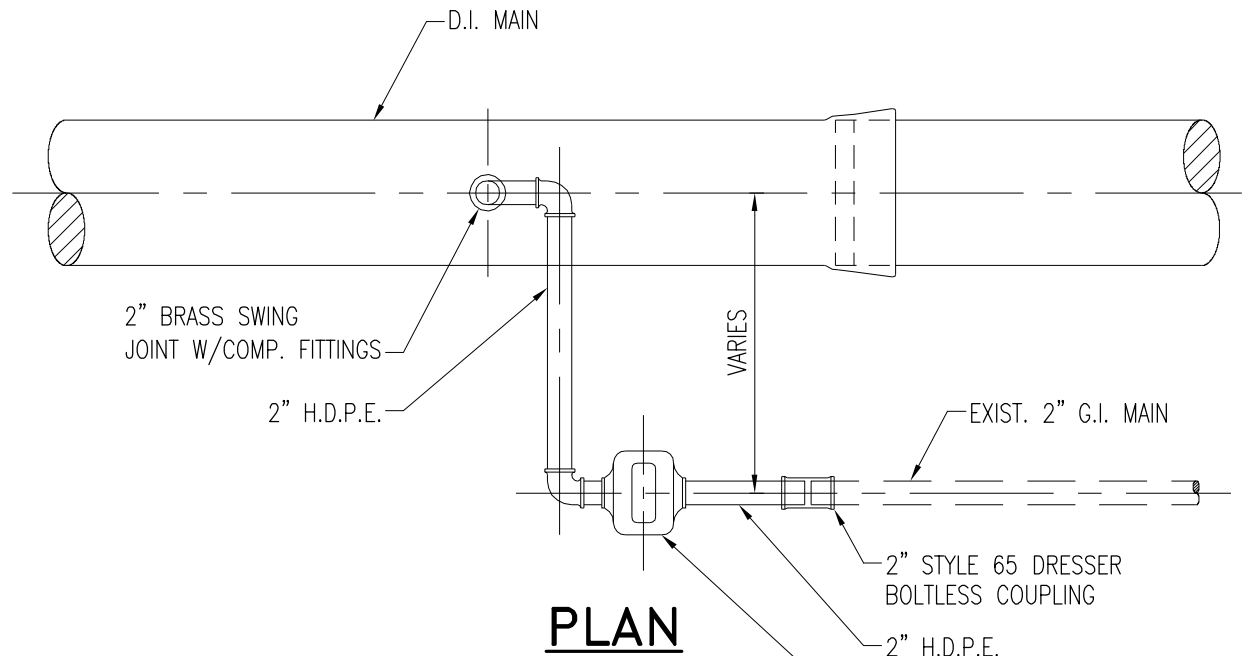

**PLAN**

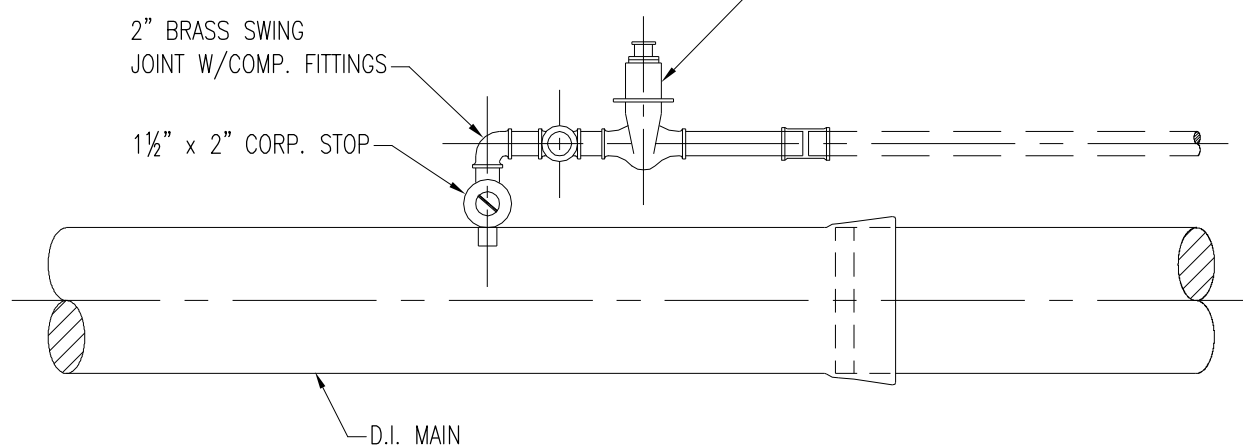

**SECTION**

**NOTES:**

1. INSTALL TAPPING SADDLE FOR:
  - THICKNESS CLASS D.I. MAINS 4" NOMINAL DIAMETER.
  - PRESSURE CLASS D.I. MAINS 10" AND SMALLER NOMINAL DIAMETER.
2. IF TAP CAN BE MADE AT A 45° ANGLE, SWING JOINT MAY BE ELIMINATED. USE CORP STOP W/COMP. FITTINGS.
3. A TEN GAUGE BLUE (PURPLE FOR RECLAIMED WATER) DIRECT BURY STRANDED COPPER TRACER WIRE TO BE TAPED CONTINUOUSLY WITH POLY OR DUCT TAPE TO THE SERVICE FOR LOCATION PURPOSES. WIRE MUST BE ATTACHED TO WATER MAIN AND EXTEND INTO THE WATER METER BOX.

TYP. GATE VALVE	WS 1.0	
ITEM	CROSS REF.	SPEC. REF.



ISSUE DATE	APPROVED BY
06/22/2009	V.F.C.

STANDARD DETAIL

**TYPICAL 2" GALVANIZED STEEL CONNECTION TO EXISTING MAIN**

**WS**  
**4.13**  
SHEET 1 OF 1

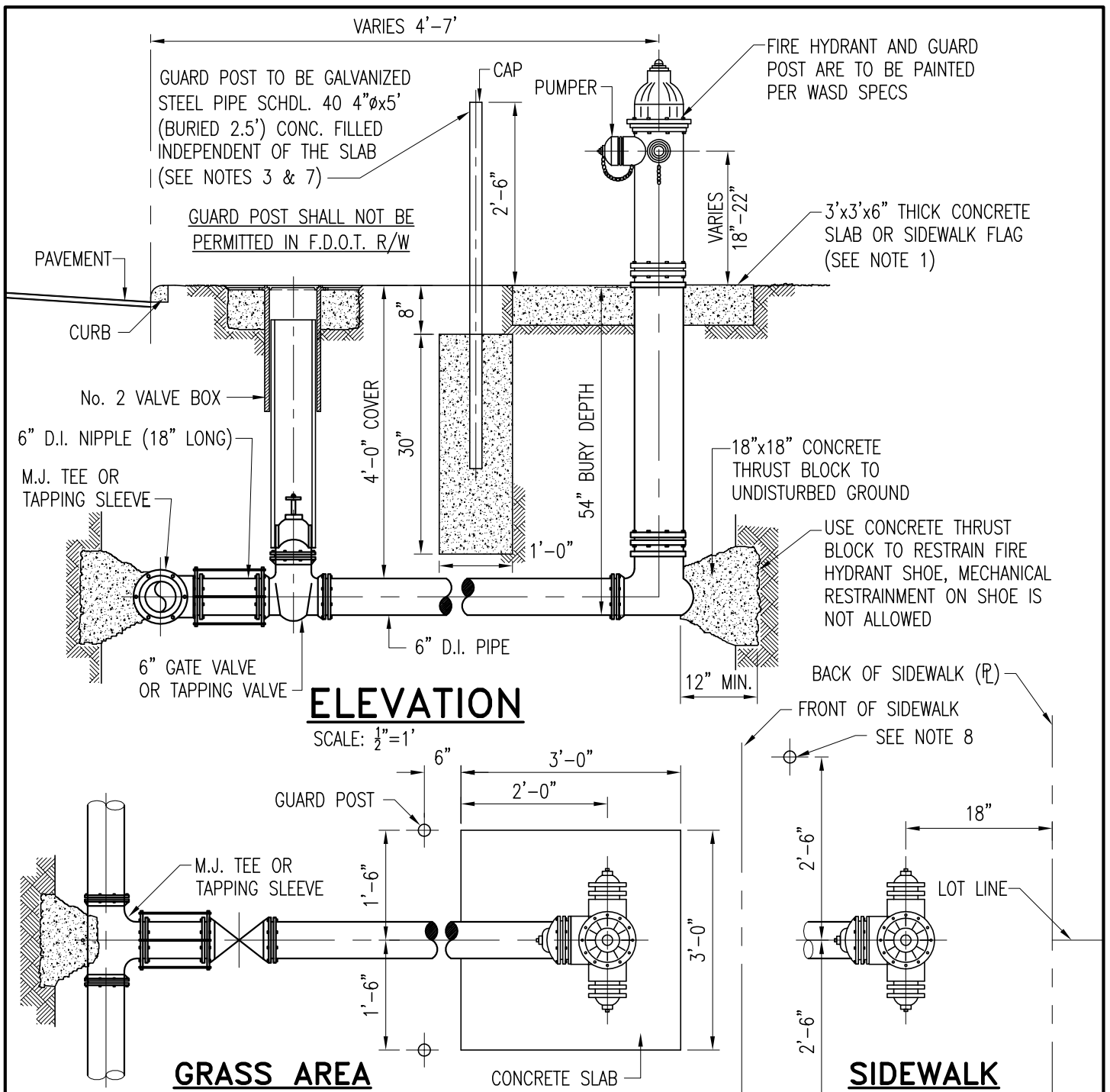

**ELEVATION**

SCALE: 1/2"=1'

**GRASS AREA**

**SIDEWALK**

**PLAN**

SCALE: 1/2"=1'

**NOTES:**

1. WHEN THE PORTION OF THE SIDEWALK IS WITHIN THE 4'-7' OFFSET, LOCATE FIRE HYDRANT 1' FROM FACE OF WALK, WITHIN GRASS AREA.
2. IN ALL OTHER CASES, CONTACT FIRE DEPARTMENT FOR FIRE HYDRANT LOCATION.
3. IN SIDEWALK LOCATE GUARD POSTS AT THE FACE OF THE PUMPER AND 2'-6" LEFT/RIGHT OF  $\phi$  OF THE FIRE HYDRANT.
4. FIRE HYDRANT SLAB AND GUARD POST CONCRETE WORK SHALL BE DIFFERENT POURS.
5. EXTRA POSTS MAY BE REQUIRED IN INDUSTRIAL AND CONGESTED TRAFFIC AREAS.
6. FIRE HYDRANTS SHALL NOT BE LOCATED WITHIN A RADIUS.
7. GUARD POSTS SHALL NOT BE ALLOWED IN F.D.O.T. R/W (SEE SHEET 2 OF 2)
8. POSTS TO BE INSTALLED AT DISCRETION OF INSPECTOR.

CONC. ANCHOR	GS 1.1	
No. 2 VALVE BOX	WS 3.10	
TYP. TIE ROD DETAIL	GS 1.0	
TYP. GATE VALVE	WS 1.0	
ITEM	CROSS REF.	SPEC. REF.



ISSUE DATE	APPROVED BY
02/25/2013	F.A.

STANDARD DETAIL  
**TYPICAL FIRE HYDRANT  
 INSTALLATION WITH GUARD POSTS**

**WS  
 4.50**  
 SHEET 1 OF 2

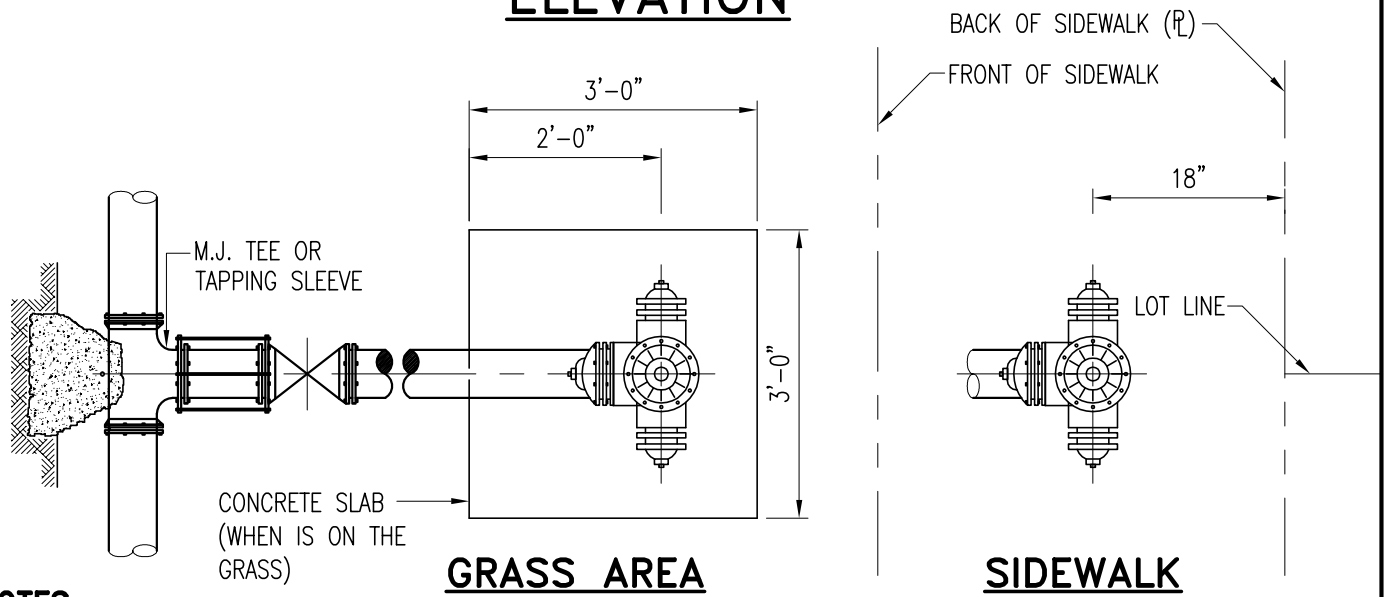
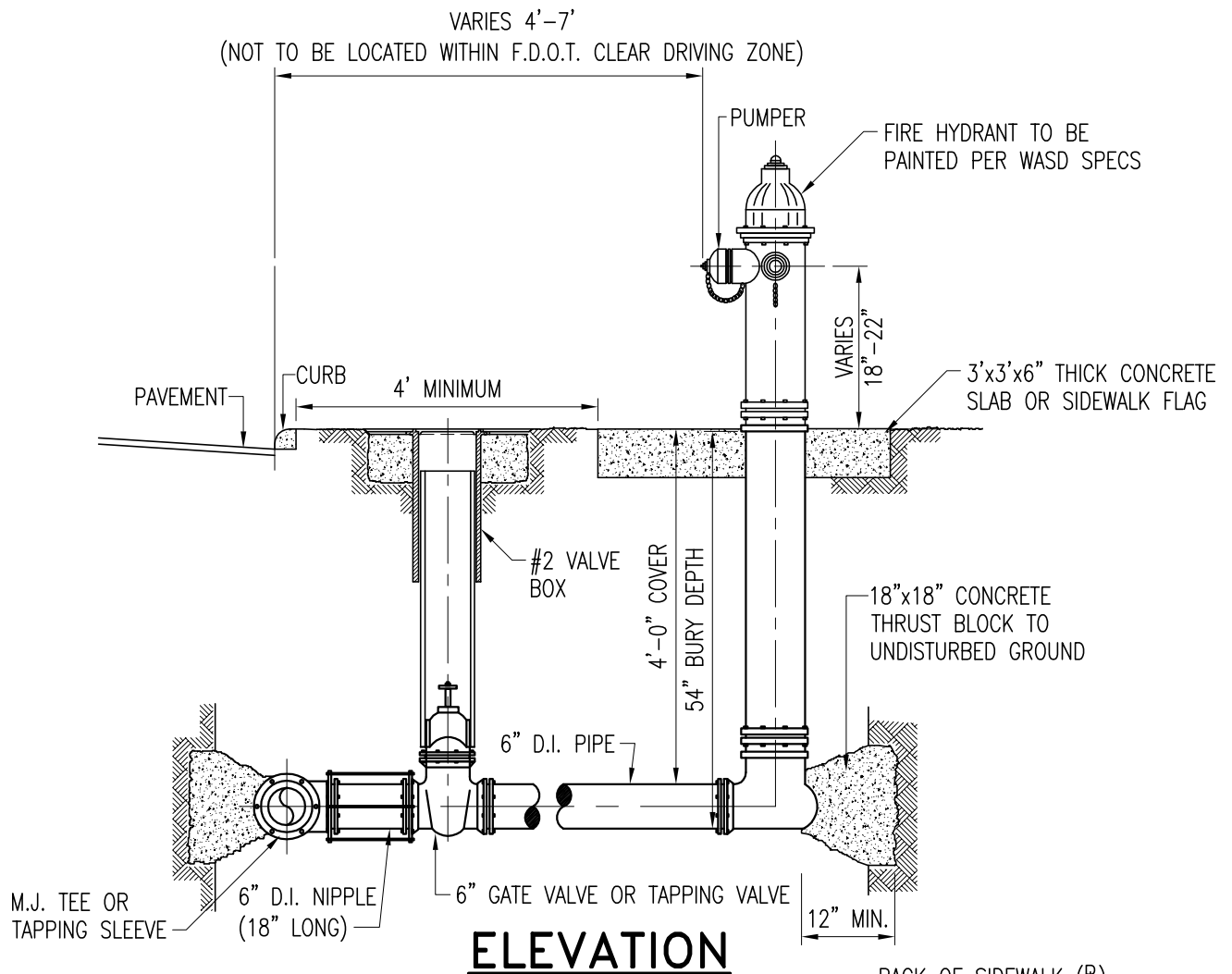

**NOTES:**

1. FIRE HYDRANTS SHALL NOT BE LOCATED WITHIN A RADIUS.
2. 1' FROM FACE OF CURB ONLY ON 4' SIDEWALKS FOR ADA.
3. IN F.D.O.T. R/W ONLY USE PLASTIC SURFACE MOUNTED DELINEATOR POST INSTALLED WITH EPOXY ADHESIVE.

ITEM	CROSS REF.	SPEC. REF.



ISSUE DATE	APPROVED BY
02/25/2013	V.F.C.

STANDARD DETAIL  
TYPICAL FIRE HYDRANT  
INSTALLATION IN F.D.O.T.  
RIGHT OF WAY

WS  
4.50  
SHEET 2 OF 2

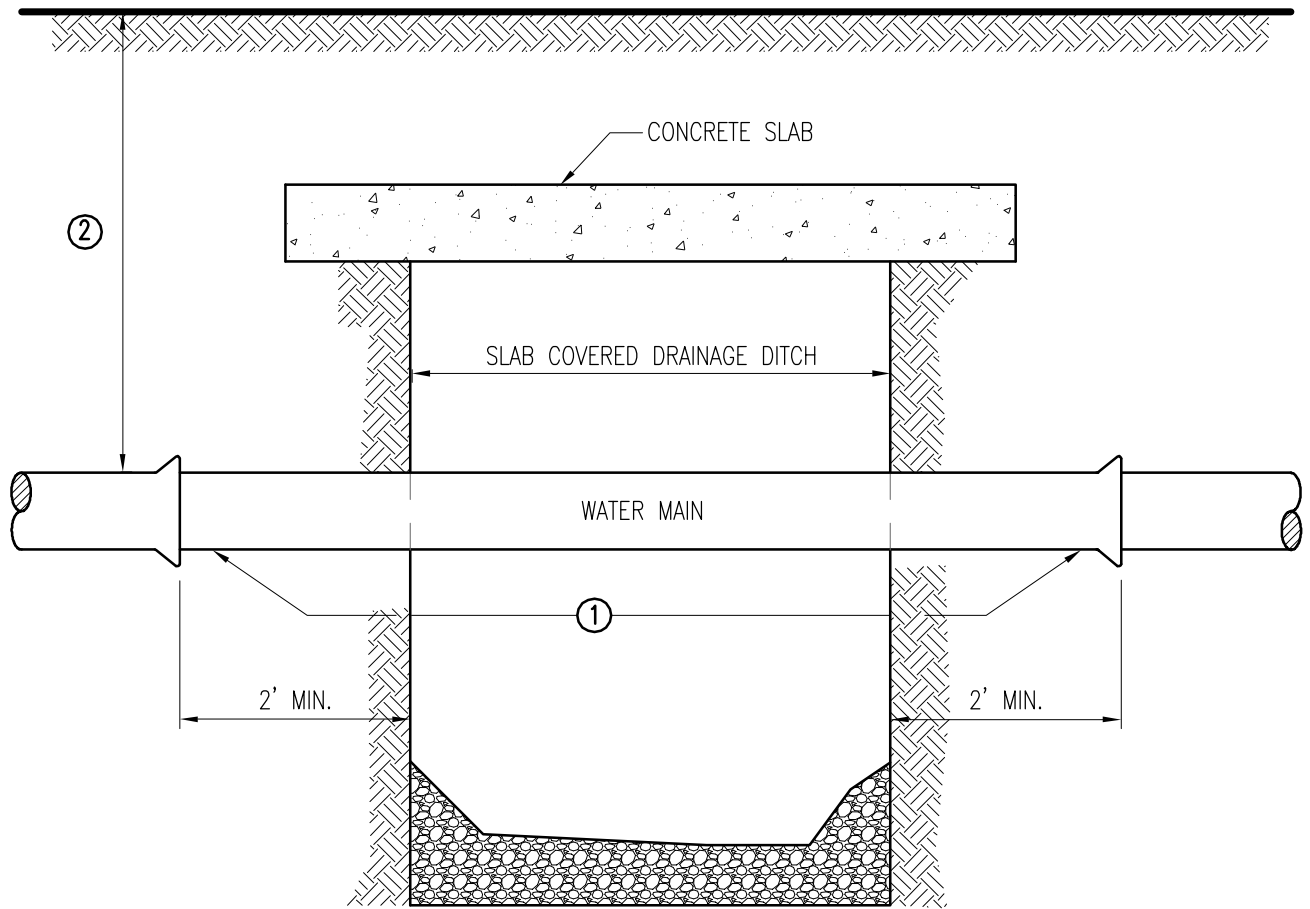

**LEGEND:**

- ① WATER MAIN SHALL BE A CONTINUOUS LENGTH OF DUCTILE IRON PIPE TO EXTEND 2 FEET MINIMUM EITHER SIDE OF THE DRAINAGE DITCH, WITH NO FITTINGS OR JOINTS WITHIN THE DITCH.
- ② 4'-0" COVER OVER WATER MAIN.

**NOTES:**

- 1. SOIL CONDITIONS MAY REQUIRE HEADWALLS. TO BE DESIGNED BY A REGISTERED PROFESSIONAL ENGINEER.
- 2. IF EXISTING DRAINAGE DITCH; BRING TOP SLAB AND SIDE WALLS TO ORIGINAL OR BETTER CONDITIONS AS PER PERMITTING AGENCIES STANDARDS.

I T E M	CROSS REF.	SPEC. REF.



ISSUE DATE	APPROVED BY
06/01/2008	V.F.C.

S T A N D A R D   D E T A I L

WATER MAIN CROSSING  
THRU DRAINAGE DITCH

WS  
4.60  
SHEET 1 OF 1

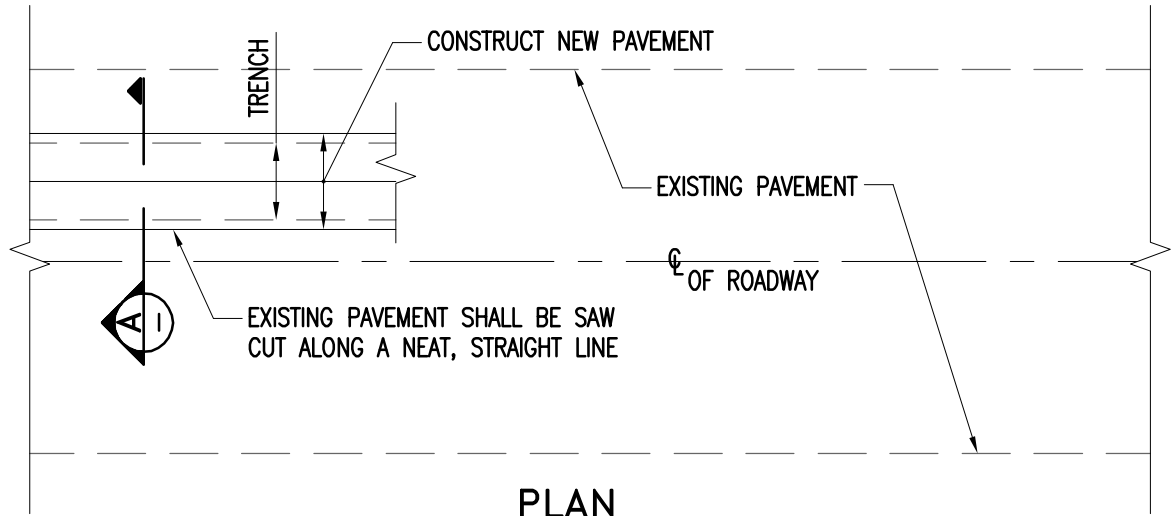

**PLAN**  
N.T.S.

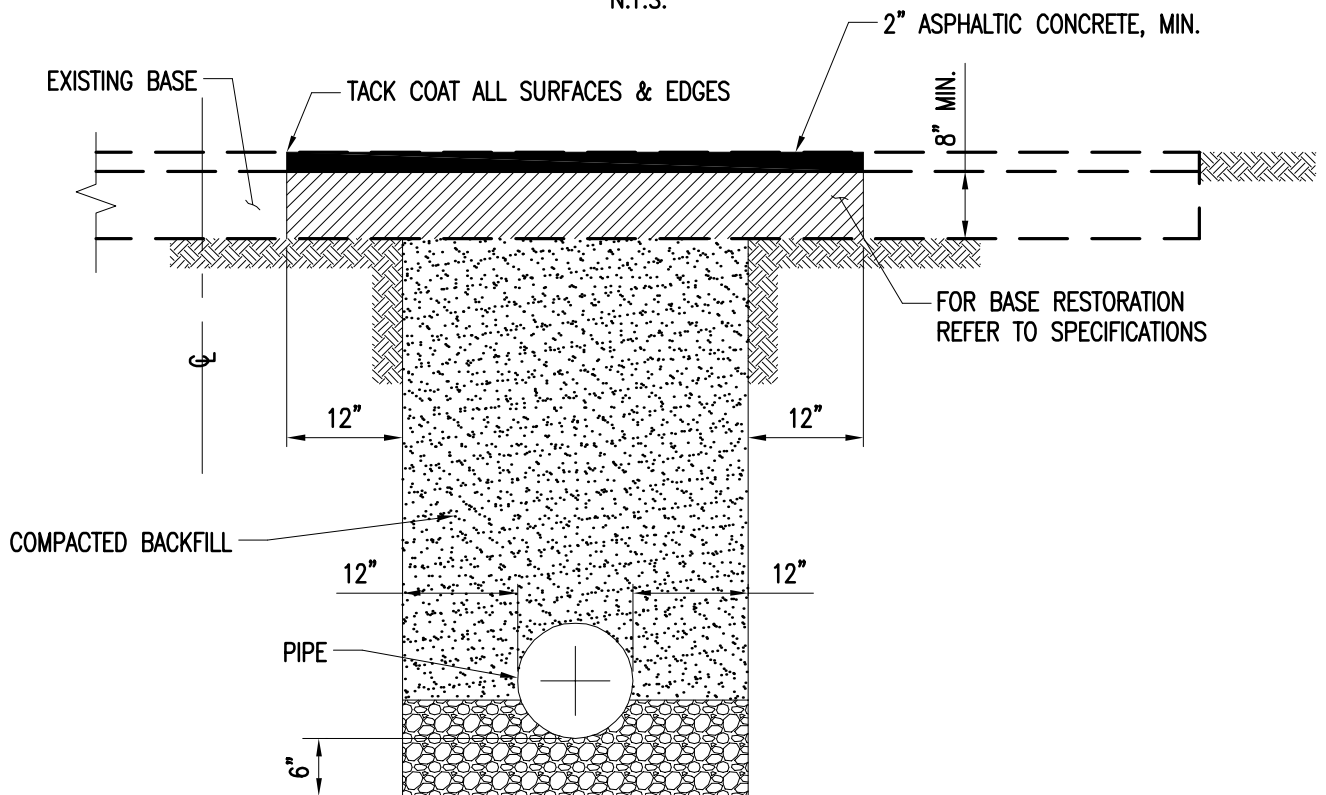

**SECTION A**  
N.T.S.

**NOTES:**

1. UNLESS OTHERWISE SPECIFIED, ALL ASPHALTIC CONCRETE DRIVEWAYS OR OIL-SAND DRIVEWAYS SHALL BE REPLACED WITH TYPE I PAVEMENT RESTORATION WITH 1" ASPHALTIC CONCRETE AND 6" BASE.
2. FOR PAVEMENT RESTORATION, REFER TO D.O.T., MIAMI-DADE COUNTY PUBLIC WORKS OR SPECIFIC MUNICIPALITY STANDARDS.

ITEM	CROSS REF.	SPEC. REF.



ISSUE DATE	APPROVED BY
10/07/2010	V.F.C.

STANDARD DETAIL  
**PAVEMENT RESTORATION  
TYPE I**

**A**  
**1.0**  
SHEET 1 OF 1

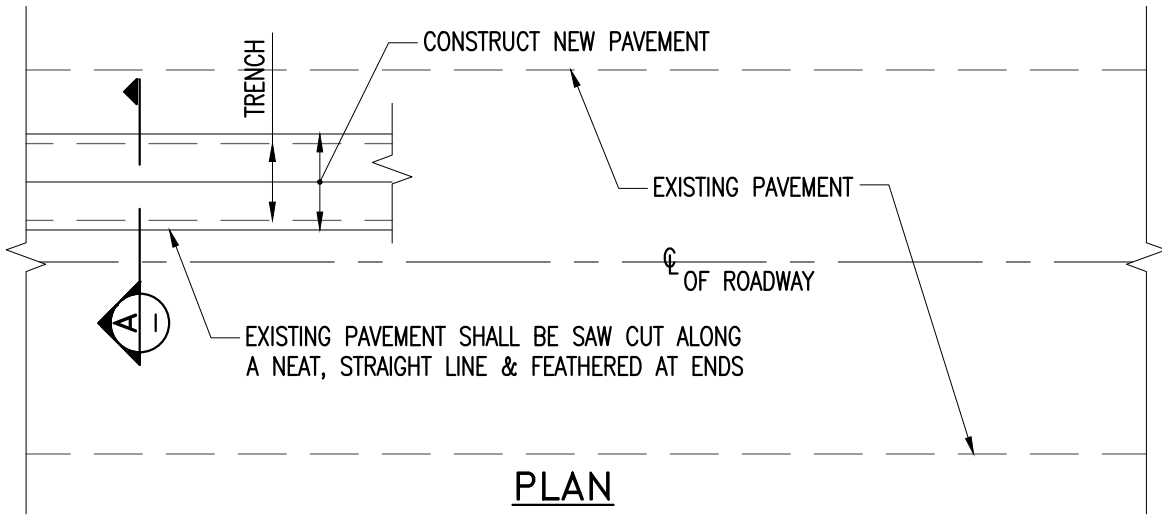

**PLAN**

N.T.S.

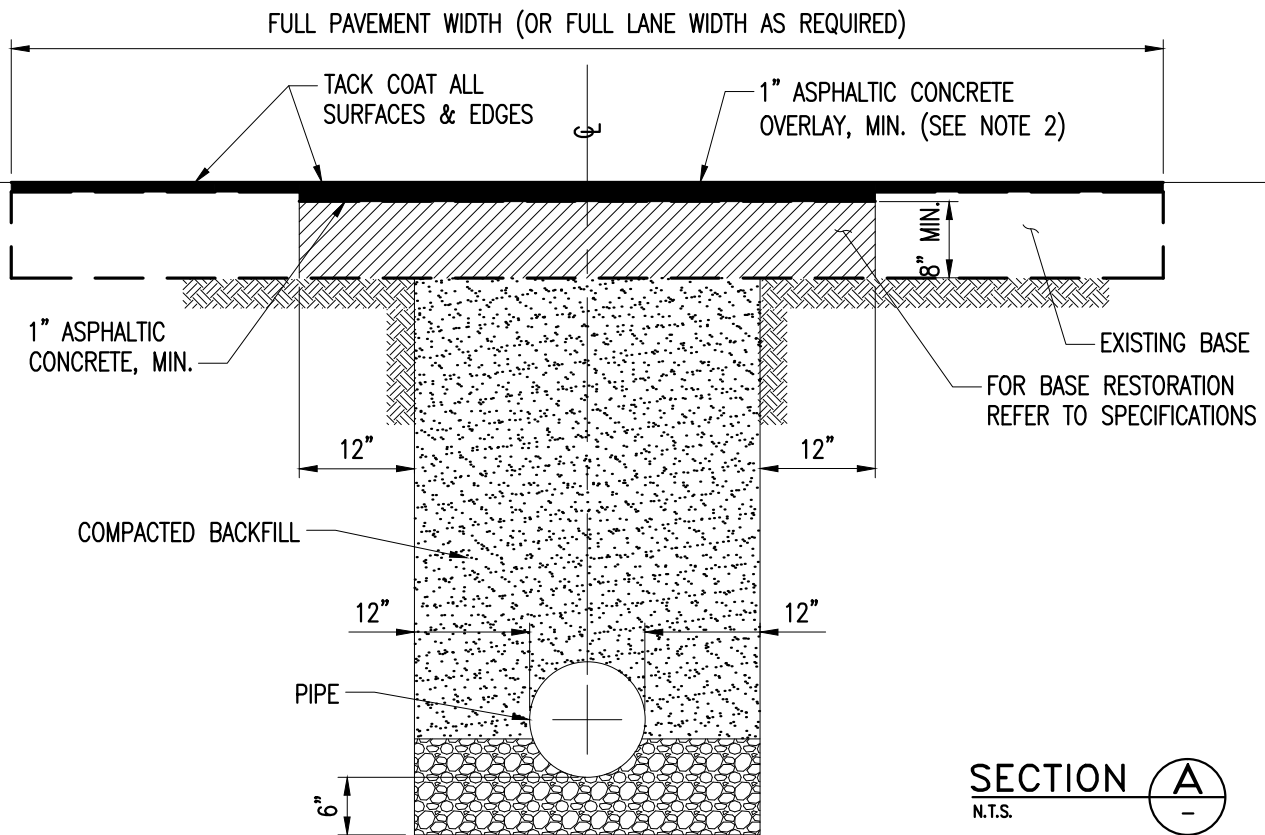

**SECTION** A  
N.T.S.

**NOTES:**

1. UNLESS OTHERWISE SPECIFIED, ALL ASPHALTIC CONCRETE DRIVEWAYS OR OIL-SAND DRIVEWAYS SHALL BE REPLACED WITH TYPE I PAVEMENT RESTORATION. (REFER TO STANDARD DETAIL A 1.0).
2. FOR PAVEMENT RESTORATION, REFER TO F.D.O.T., MIAMI-DADE COUNTY PUBLIC WORKS OR SPECIFIC MUNICIPALITY STANDARDS.
3. FOR FDOT ROADS, MILL A MINIMUM OF 1½-INCH AND OVERLAY 1½-INCH WITH FRICTION COURSE 9.5 WITH RUBBER.
4. FOR MIAMI-DADE COUNTY ROADS, MILL 1-INCH AND OVERLAY 1-INCH.

ITEM	CROSS REF.	SPEC. REF.



ISSUE DATE	APPROVED BY
08/02/2013	J.B.F.

STANDARD DETAIL  
**PAVEMENT RESTORATION  
TYPE V**

**A**  
**1.1**  
SHEET 1 OF 1

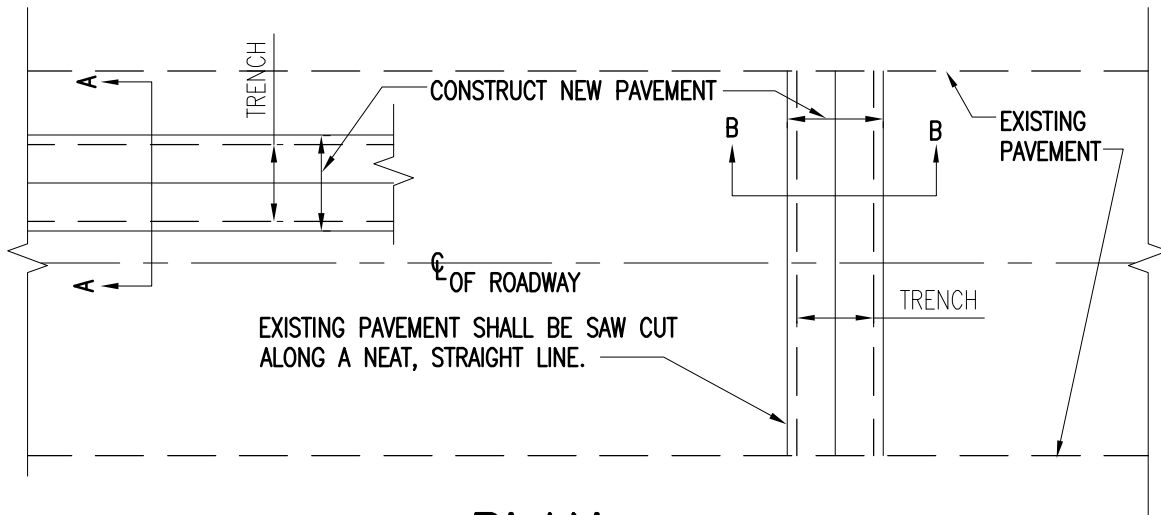

**PLAN**

FOR PAVEMENT RESTORATION, REFER TO D.O.T., MIAMI DADE COUNTY PUBLIC WORKS OR SPECIFIC MUNICIPALITY STANDARDS.

ASPHALTIC CONCRETE THICKNESS TO BE THE SAME AS ADJACENT ROADWAY, OR 1½ INCH MIN.

TACK COAT ALL SURFACES & EDGES

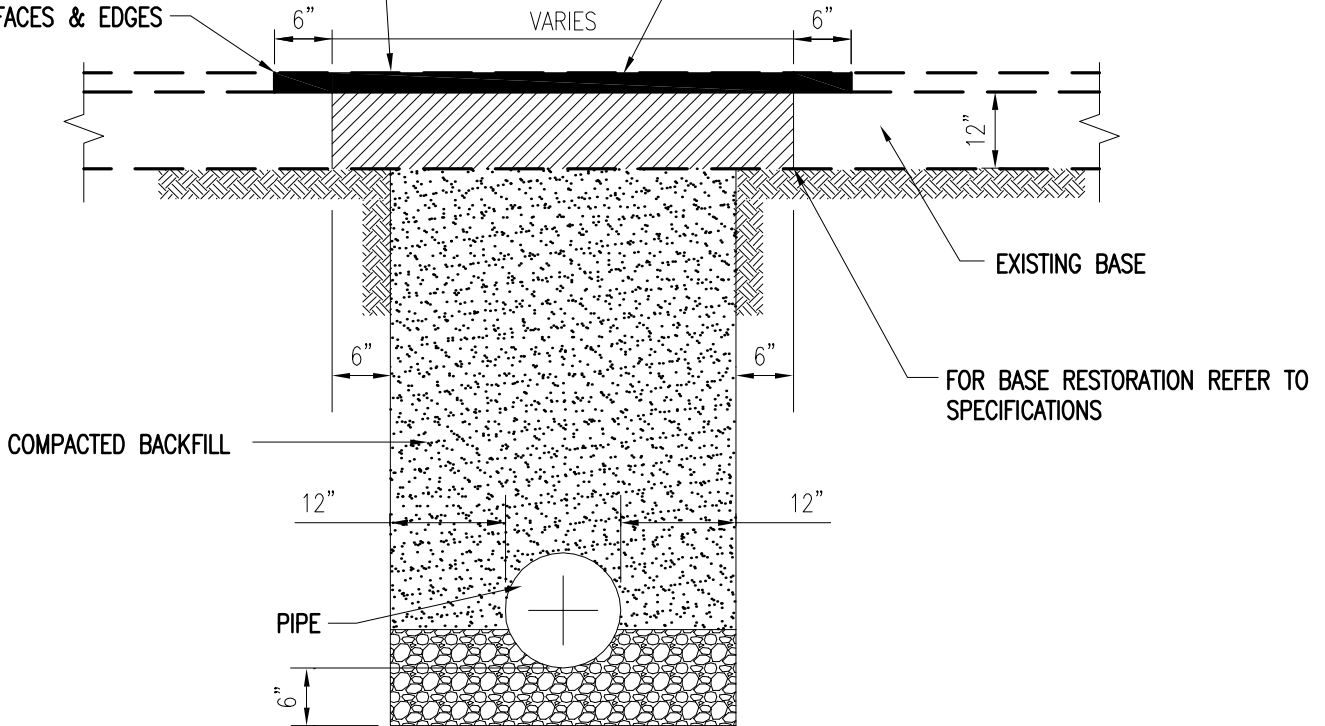

**SECTION A-A & B-B**

ITEM	CROSS REF.	SPEC. REF.

STANDARD DETAIL

PAVEMENT RESTORATION  
TYPE "M"

A  
4.0  
SHEET 1 OF 1



ISSUE DATE	APPROVED BY
11/01/2006	V.E.F.



Method "A"

Cut the polyethylene tube 2 ft. longer than the length of pipe section. Slip the tube around the pipe so as to allow 1 ft. overlap at each end. Overlap the other pipe section after pipe is installed.

Method "B"

Cut the polyethylene tube 1 ft. shorter than the length of pipe sections. Slip the tube around the pipe so as to allow 6 in. of bare pipe at each end. Before making a joint, slip a 3 ft. Length of polyethylene tube over the preceding pipe section. Overlap by at least 1 ft. and secure, after joint is made.

Method "C"

Wrap odd shaped fitting with sheet or split length of polyethylene tube by passing the sheet under the fitting and bringing it up around the body. Make seams by bringing it folding over twice, and taping down. Tape sheet securely in place at valve stem and other penetrations.

NOTES:

1. The Department reserves the right to require polyethylene encasement wherever, in their opinion, corrosive soils exist.
2. Tube size will be as listed in table.
3. Pipe-shape fittings (bends, reducers, etc.) shall be treated according to Methods "A" and "B". Odd shaped fittings (valves, tees, etc.) shall be treated according to Method "C".
4. 6" adhesive tape shall be used to secure encasement.
5. Special care shall be taken to prevent damage to wrapping when placing backfill.
6. Refer to ASTM D1248 for approved material and accessories.
7. Only virgin polyethylene material having a minimum thickness of 8 mils is approved.

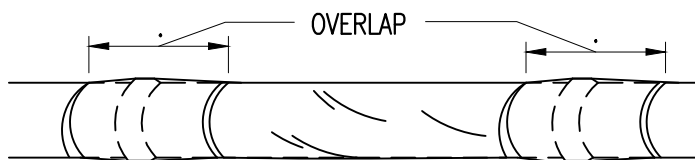

METHOD A (TUBE)

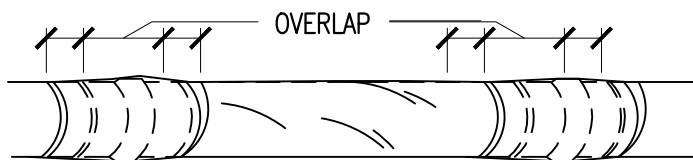

METHOD B (TUBE)

TABLE	
NOMINAL PIPE DIAMETER (IN)	POLYETHYLENE FLAT TUBE WIDTH (IN)
4	16
6	20
8	24
12	30
16	37
20	45
24	54
30	67
36	81
42	95
48	108
54	121

ITEM	CROSS REF.	SPEC. REF.



ISSUE DATE	APPROVED BY
10/29/2010	V.E.F.

STANDARD DETAIL  
**POLYETHYLENE ENCASEMENT  
 FOR  
 DUCTILE IRON PIPE**

**A**  
**9.0**  
 SHEET 1 OF 1

ADAP.	Adapter
A.R.V.	Air Release Valve
ASPH.	Asphalt
A.C.P.	Asbestos Cement Pipe
Ave.	Avenue
BL	Base Line
B.J.	Break Joint
B.	Bell
B.O.	Blow-Off
BOT.	Bottom
BUTT. V.	Butterfly Valve
CL	Center Line
C.V.	Check Valve
COR.	Corner
C.B.	Catch Basin
C.C.	Center to Center
C.I.P.	Cast Iron Pipe
CONN.	Connection
CONC.	Concrete
COND.	Conduit
CONT.	Contract
C.B. #	Core Boring #
C.M.P.	Corrugated Metal Pipe
CORP. STOP	Corporation Stop
CU. YD.	Cubic Yard
DET.	Detail
D.I.P.	Ductile Iron Pipe
DWG.	Drawing
DIV.	Division
DWY.	Driveway
E.	East
EL.	Elevation
ELEC.	Electric
E.O.P.	Edge of Pavement
EXIST.	Existing
F.B.	Full Bevel
F.B. #	Field Book No.
F.H.	Fire Hydrant
FLG.	Flanged - Flange
F.O.	Flanged Outlet
FTG.	Footing
F.M.	Force Main
F.V.O.	Flushing Valve Outlet
GALV.	Galvanized
G.I.A.	Galvanized Iron Pipe
G.	Gas
G.V.	Gate Valve
GA.	Gauge

ITEM	CROSS REF.	SPEC. REF.



ISSUE DATE	APPROVED BY
06/01/2008	V.F.C.

STANDARD DETAIL  
**ABBREVIATIONS FOR  
DEPARTMENT'S PROJECTS**

**A  
10.0  
SHEET 1 OF 3**

H.B.J.	Horizontal Break Joint
H.L.	Horizontal length
H.B.	Half Bevel
H.F.B.	Horizontal Full Bevel
H.H.B.	Horizontal Half Bevel
INT.	Interceptor
INV.	Invert
LAT.	Lateral
LGTH.	Length
L.L.	Laid Length
L.P.	Light Pole
LT.	Left
LOC.	Location
M.B.	Mail Box
MH.	Manhole
MIN.	Minimum
MAX.	Maximum
M.J.	Mechanical Joint
M	Monument Line
NIP.	Nipple
N.	North
No.	Number
PVMT.	Pavement
P.E.	Plain End
P.V.	Plug Valve
PSI	Pounds per Square Inch
P	Property Line
P.C.	Point of Curvature
P.C.C.P.	Prestressed Concrete Cylinder Pipe
P.T.	Point of Tangency
P.I.	Point of Intersection
LBS.	Pounds
P.O.	Push-on
PROP.	Proposed
P.V.A.	Polyvinyl Chloride
RT.	Right
R/W	Right of Way
R.C.P.	Reinforced Concrete Pipe
REQ'D.	Required
REST.	Restrained
RGE.	Range
REV.	Revised–Revision
SH.	Short
§	Section Line
S.	South
SQ. FT.	Square Feet
S.	Spigot

ITEM	CROSS REF.	SPEC. REF.



<u>ISSUE DATE</u>	<u>APPROVED BY</u>
06/01/2008	V.F.C.

S T A N D A R D   D E T A I L

A B B R E V I A T I O N S   F O R  
D E P A R T M E N T ' S   P R O J E C T S

A  
10.0  
SHEET 2 OF 3

SEC.	Section
SHT.	Sheet
SLV.	Sleeve
STL. P.	Steel Pipe
ST.	Street
SAN.	Sanitary Sewer
S.S.	Storm Sewer
STA.	Station
SPK.	Sprinkler
TAP. SLV.	Tapping Sleeve
TAP. V.	Tapping Valve
TEL.	Telephone
TEL. BOX	Telephone Box
T.F.O.	Tapping Flanged Outlet
T.L.	Traffic Light
T.O.P.	Top of Pipe
TRANS. P.	Transite Pipe
TWP.	Township
TYP.	Typical
T.R.	Thrust Resistant
U.P.	Utility Pole
UNK.	Unknown
V.C.P.	Vitrified Clay Pipe
W.	West
W.M.	Water Main
W/O	Without
W. MTR.	Water Meter
X.	Extra

ITEM	CROSS REF.	SPEC. REF.

**APPENDIX "C"**

**MIAMI-DADE  
WATER AND SEWER DEPARTMENT**

**WASD ID CARD SECURITY PROCEDURES  
NON-WASD EMPLOYEES**

**( Not Used )**

**APPENDIX "D"**

**MIAMI-DADE COUNTY CODE  
SECTION 2-8.4. PROTEST PROCEDURES**

**MIAMI-DADE COUNTY  
ADMINISTRATIVE ORDER NO. 3-21  
BID PROTEST PROCEDURES**

**( Not Used )**

**APPENDIX "E"**

**QUARTERLY REPORTS**

**( 2 Pages )**

**QUARTERLY REPORTS**

(MIAMI-DADE COUNTY CONTRACT WORK)

\_\_\_\_\_ (name of County Contractor),  
pursuant to County Resolution R-1634-93, has for the \_\_\_\_\_ (1st, 2nd, 3rd or 4th) Quarter  
of 20 \_\_\_\_\_, received the following sum from Miami-Dade County on all Miami-Dade County  
projects or contracts the Contractor had during the Quarter.

\$ \_\_\_\_\_ dollars and \_\_\_\_\_ cents.

By: \_\_\_\_\_  
Signature of Representative of Contractor

\_\_\_\_\_  
Printed Name of Representative of Contractor

\_\_\_\_\_  
Capacity of Representative, if not a Sole Proprietorship

\_\_\_\_\_  
\_\_\_\_\_  
\_\_\_\_\_  
Address of Contractor



**QUARTERLY REPORTS**

(PRIVATE SECTOR WORK)

\_\_\_\_\_ (name of County Contractor),  
pursuant to County Resolution R-1634-93, has for the \_\_\_\_\_ (1st, 2nd, 3rd or 4th) Quarter  
of 20\_\_\_\_\_, received the following sum on Private Sector Work the Contractor had during the  
Quarter.

\$ \_\_\_\_\_ dollars and \_\_\_\_\_ cents.

By: \_\_\_\_\_  
Signature of Representative of Contractor

\_\_\_\_\_  
Printed Name of Representative of Contractor

\_\_\_\_\_  
Capacity of Representative, if not a Sole Proprietorship

\_\_\_\_\_  
\_\_\_\_\_  
\_\_\_\_\_  
Address of Contractor

**APPENDIX "F"**

**MIAMI-DADE COUNTY  
ORDINANCE NO. 99-152  
ORDINANCE RELATING TO FALSE CLAIMS**

**( 13 Pages )**

MEMORANDUM

Amended  
Agenda Item No. 4(C)

(Public Hearing 11-2-99)

TO: Hon. Chairperson and Members  
Board of County Commissioners

DATE: October 19, 1999

FROM: Robert A. Ginsburg  
County Attorney

SUBJECT: Ordinance relating to  
false claims

O#99-152

The accompanying ordinance was prepared and placed on the agenda at the request of  
Commissioner Katy Sorenson.

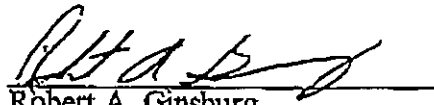
  
Robert A. Ginsburg  
County Attorney

RAG/bw



MEMORANDUM

TO: Hon. Chairperson and Members  
Board of County Commissioners

DATE: November 2, 1999

SUBJECT: Agenda Item No. 4(C)

FROM: Robert A. Ginsburg  
County Attorney

99-152

Please note any items checked.

- "4-Day Rule" (Applicable if raised)
- 6 weeks required between first reading and public hearing
- Decreases revenues or increases expenditures without balancing budget
- Budget required
- Statement of fiscal impact required
- Statement of private business sector impact required
- Bid waiver requiring County Manager's written recommendation
- Ordinance creating a new board requires a detailed County Manager's report for public hearing
- "Sunset" provision required
- Legislative findings necessary



# MEMORANDUM

107.07-17A MEMO DATED 11-02-99

TO: Honorable Chairperson and Members  
Board of County Commissioners

DATE: November 2, 1999

FROM:   
M. R. Stierheim  
County Manager

SUBJECT: Fiscal Impact of Proposed  
Ordinance Prohibiting  
Presentation, Maintenance  
Prosecution of false or Fraudulent  
Claims against Miami-Dade  
County

99 - 152

This ordinance will have a positive impact to the County, although it is not possible to estimate the value. Any enforcement cost will be offset by the penalties imposed by this ordinance.

Fisca/0800

Approved \_\_\_\_\_ Mayor  
Veto \_\_\_\_\_  
Override \_\_\_\_\_

Amended  
Agenda Item No. 4(C)  
11-2-99

ORDINANCE NO. 99-152

ORDINANCE PROHIBITING PRESENTATION, MAINTENANCE, OR PROSECUTION OF FALSE OR FRAUDULENT CLAIMS AGAINST MIAMI-DADE COUNTY; REQUIRING FORFEITURE OF ANY CLAIM CONTAINING FALSE OR FRAUDULENT ALLEGATIONS OR STATEMENTS; IMPOSING PENALTIES FOR SUBMISSION OF FALSE OR FRAUDULENT CLAIMS; PROVIDING BOTH COUNTY AND PRIVATE ENFORCEMENT; AND PROVIDING SEVERABILITY, INCLUSION IN THE CODE, AND AN EFFECTIVE DATE

BE IT ORDAINED BY THE BOARD OF COUNTY COMMISSIONERS OF MIAMI-DADE COUNTY, FLORIDA:

Section 1. Sections 21-255 through 21-266 of the Code of Miami-Dade County, Florida, are hereby created to read as follows:<sup>1</sup>

>>Section 21-255. Short title; purpose.

(1) This article shall be known and may be cited as the Miami-Dade County False Claims Ordinance.

(2) The purpose of the Miami-Dade County False Claims Ordinance is to deter persons from knowingly causing or assisting in causing the County to pay claims that are false, fraudulent, or inflated, and to provide remedies for obtaining damages and civil penalties for the County when money is sought or obtained from the County by reason of a false claim.

(3) The provisions of this article are not exclusive, and the remedies provided for in this article shall be in addition to any other remedies provided for in any other law, or available under common law, or otherwise.

<sup>1</sup> Words stricken through and/or [[double bracketed]] shall be deleted. Words underscored and/or >>double arrowed<< constitute the amendment proposed. Remaining provisions are now in effect and remain unchanged.

(4) This article shall be liberally construed and applied to promote the public interest.

Section 21-256. Definitions.

The following terms and phrases when used in this article shall have the meanings ascribed to them in this section, except when the context clearly indicates a different meaning:

(1) "Bid takeoff" means the final estimate, tabulation, or worksheet prepared by the contractor in anticipation of the bid submitted, and which shall reflect the final bid price.

(2) "Claim" means any invoice, statement, request, demand, lawsuit, or action, under contract or otherwise, for money, property, or services made to any employee, officer, or agent of the County, or to any contractor, grantee, or other recipient if any portion of the money, property, or services requested or demanded was issued from, or was provided by, the County (hereinafter "County funds").

(3) "Claimant" means any person who brings, submits, files, maintains, or pursues a claim.

(4) "County" means the government of Miami-Dade County or any department, division, bureau, section, commission, planning agency, board, district, authority, agency, or instrumentality of the County, including the Miami-Dade County Public Health Trust.

(5) "Extended overhead" means the amount of a claim relating to an increase in overhead costs resulting from a delay in contract performance that is not compensated by a markup of direct costs.

(6) "Knowing" or "knowingly" means that a person, with respect to information:

(a) has actual knowledge of the information;

(b) acts in deliberate ignorance of the truth or falsity of the information; or

(c) acts in reckless disregard of the truth or falsity of the information.

(7) "Overhead per diem" means the amount calculated by dividing the total overhead costs set forth in the final bid takeoff by the number of days for substantial completion of the work set forth in the contract.

(8) "Person" means any natural person, corporation, firm, association, organization, partnership, agency, limited liability company, business, or trust.

Section 21-257. Certification of claims.

(1) Upon the request of the County, the person submitting a claim shall, within thirty (30) days, including Saturdays, Sundays, and legal holidays, submit a certified claim as defined by this section. A "certified claim" shall be made under oath by a person duly authorized by the claimant, and shall contain a statement that:

(a) the claim is made in good faith;

(b) the claim's supporting data are accurate and complete to the best of the person's knowledge and belief;

(c) the amount of the claim accurately reflects the amount that the claimant believes is due from the County; and

(d) the certifying person is duly authorized by the claimant to certify the claim.

(2) Failure to provide the requested certification within the prescribed thirty-day (30) period shall constitute a forfeiture of the entire claim.

Section 21-258. Liability for false claims; penalties.

(1) The following action(s) shall constitute a violation of this ordinance:

(a) any person who knowingly presents or causes to be presented to the County, or to any officer, employee, agent, or consultant of the County, a false or fraudulent claim for payment or approval;

(b) any person who knowingly makes, uses, or causes to be made or used, a false record or statement to get a false, fraudulent, or inflated claim paid or approved by the County;

(c) any person who conspires to defraud the County by facilitating the payment of a false, fraudulent, or inflated claim allowed or paid by the County;



(d) any person who delivers, with the intent to defraud the County, goods or services of different quality or quantity than that specified in the applicable contract or specification;

(e) any person who is authorized to make or deliver a document certifying receipt of property used, or to be used, by the County and, intending to defraud the County, makes or delivers the receipt without completely knowing that the information on the receipt is true;

(f) any person who knowingly buys, or receives as a pledge of an obligation or debt, public property from an officer, employee, or agent of the County who lawfully may not sell or pledge the property; or

(g) any person who knowingly makes, uses, or causes to be made or used, a false record or statement to conceal, avoid, or decrease an obligation to pay or transmit money or property to the County.

(2) Any beneficiary of an inadvertent submission of a false claim to the County, who subsequently discovers the falsity of the claim, and who fails to disclose the falsity of the claim to the County within thirty (30) days of discovering the error, shall also be found to have submitted a false claim to the County.

(3) Any person found to have submitted a false claim to the County shall:

(a) be liable to the County for an amount equal to three times that part of the claim which is false, fraudulent, or inflated;

(b) immediately, fully, and irrevocably forfeit the entire amount of the claim;

(c) be liable to the County for all costs and fees (including, without limitation, reasonable legal, expert, and consulting fees) incurred by the County to review, defend, and evaluate the claim; and

(d) be subject to debarment from County contracting for a period not to exceed five (5) years. Additionally, any person who certified a claim later found to be false shall be subject to debarment from County contracting for a period not to exceed five (5) years.

(4) Liability under this section shall be joint and several for any act committed by two or more persons.

Section 21-259. Civil actions for false claims.

(1) The County Manager may investigate a violation under Section 21-258. If the County Manager finds that a person has violated or is violating Section 21-258, he or she may bring a civil action against the person on behalf of the County.

(2) A person may bring a civil action for a violation of Section 21-258 for the person and for the County. Civil actions instituted under this ordinance shall be governed by the Florida Rules of Civil Procedure and shall be brought in the name of the County.

(a) The complaint shall be identified on its face as a qui tam action and shall be filed under seal in the circuit court of the Eleventh Judicial Circuit, in and for Miami-Dade County. Immediately upon filing of a complaint by a person, a copy of the complaint and written disclosure of substantially all material evidence and information the person possesses shall be served on the County Manager by registered mail, return receipt requested. The County Manager may elect to proceed with the action, in lieu of the qui tam plaintiff, on behalf of the County, within 180 days after he or she receives both the complaint and the material evidence and information.

(b) The County Manager, for good cause shown, may petition the court to extend the time during which the complaint remains under seal under subsection (a). Any such motion may be supported by affidavits or other submissions in camera. The defendant is not required to respond to any complaint filed under this section until twenty (20) days after the complaint is unsealed and served upon the defendant in accordance with law.

(c) Before the expiration of the 180-day period or any extensions obtained under subsection (b), the County Manager shall:

i. proceed with the action, in which case the action is conducted by the County Attorney on behalf of the County; or

ii. notify the court that the County declines to take over the action, in which case the person bringing the action has the right to conduct the action.

(d) When a person files an action under this section, no person other than the County Manager on behalf of the County may intervene or

bring an action under this ordinance based on the facts underlying the pending action.

Section 21-260. Rights of the parties in civil actions.

(1) If the County Manager, on behalf of the County, elects to proceed with the action, he or she has the primary responsibility for prosecuting the action, and is not bound by any prior or subsequent act(s) of the person bringing the action. The County may also voluntarily dismiss the action notwithstanding the objections of the person bringing the action.

(2) If the County Manager elects not to proceed with the action, the person bringing the action has the right to conduct the action. If the County Manager so requests, he or she shall be served with copies of all pleadings and motions filed in the action and copies of all deposition transcripts. When the person bringing the action proceeds with the claim, the court may permit the County to take over the action on behalf of the County at a later date upon a showing of good cause.

(3) Nothing in this ordinance shall be construed to limit the authority of the County or the qui tam plaintiff, proceeding pursuant to Section 21-259(2), to compromise a claim brought in a complaint filed under this ordinance if the court determines, after a hearing, that the proposed settlement is fair, adequate, and reasonable under all the circumstances.

Section 21-261. Awards to plaintiffs bringing action.

(1) If the County proceeds with and prevails in an action brought by a person under this ordinance, except as provided in subsection (2), the court shall order the distribution to the person of 10 percent of the proceeds recovered under any judgment obtained by the County in an action under Section 21-258 or of the proceeds of any settlement of the claim.

(2) If the County proceeds with an action which the court finds to be based primarily on disclosures of specific information, other than that provided by the person initiating the action, relating to allegations or transactions in a criminal, civil, or administration hearing; a legislative, administrative, or inspector general report, hearing, audit, or investigation; or from the news media, the court may award such sums as it considers appropriate, but in no case more than 5 percent of the proceeds recovered under a judgment or received in settlement of a claim under this ordinance, taking into account the significance of the information and the role of the person bringing the action in advancing the case to litigation.

(3) If the County does not proceed with an action under this ordinance, the person bringing the action or settling the claim shall receive 25 percent of the

proceeds recovered under a judgment rendered in an action under this ordinance or in settlement of a claim under this ordinance.

(4) Any payment under this section to the person bringing the action shall be paid only out of the proceeds recovered from the defendant.

(5) Whether or not the County proceeds with the action, if the court finds that the action was brought by a person who planned, initiated, or furthered the violation of Section 21-258 upon which the action was brought, the person shall be dismissed from the civil action and shall not receive any share of the proceeds of the action. Such dismissal shall not prejudice the right of the County to continue the action.

Section 21-262. Expenses; attorney's fees and costs.

(1) If the County initiates an action under this ordinance or assumes control of an action brought by a person under this ordinance, and the County prevails in such action, the County shall be awarded its reasonable attorney's fees, expenses, and costs.

(2) If the court awards the person bringing the action proceeds under this ordinance, the person shall also be awarded an amount for reasonable attorney's fees and costs. Payment for reasonable attorney's fees and costs shall be made from the recovered proceeds before the distribution of any award.

(3) If the County does not proceed with an action under this ordinance and the defendant is the prevailing party, the court shall award the defendant reasonable attorney's fees and costs against the person bringing the action.

(4) No liability shall be incurred by the County for any expenses, attorney's fees, or other costs incurred by any person in bringing or defending an action under this ordinance, except as otherwise specifically provided by law.

Section 21-263. Exemptions to civil actions.

(1) In no event may a person bring an action under Section 21-258 based upon allegations or transactions that are the subject of a civil action or an administrative proceeding in which the County is already a party.

(2) No court shall have jurisdiction over an action brought under this ordinance based upon the public disclosure of allegations or transactions in a criminal, civil, or administrative hearing; in a legislative, administrative, or inspector general report, hearing, audit, or investigation; or from the news media, unless the action is brought by the County, or unless the person bringing the action is an original source of the information. For purposes of this subsection,

the term "original source" means an individual who has direct and independent knowledge of the information on which the allegations are based and has voluntarily provided the information to the County Manager before filing an action under this ordinance based on the information.

(3) No court shall have jurisdiction over an action where the person bringing the action under Section 21-258 is:

(a) acting as an attorney for the County; or

(b) an employee or former employee of the County.

and the action is based, in whole or in part, upon information obtained in the course or scope of County employment.

(4) No court shall have jurisdiction over an action where the person bringing the action under Section 21-258 obtained the information from an employee or former employee of the County.

**Section 21-264. Protection for participating employees.**

Any employee who is discharged, demoted, suspended, threatened, harassed, or in any other manner discriminated against in the terms or conditions of employment by his or her employer because of lawful acts done by the employee in furtherance of an action under this ordinance, including investigation for, initiation of, testimony for, or assistance in an action filed or to be filed under this ordinance, shall have a cause of action under Florida Statutes, Section 112.3187.

**Section 21-265. Burden of proof; presumption of false claim.**

(1) Whenever practicable, bid specifications for County contracts shall contain a requirement that the successful bidder maintain, as a condition precedent to submitting a claim against the County, a final bid takeoff. The final bid takeoff shall contain a line item for allocation of overhead costs.

(2) Upon request from the County, a contractor making a claim against the County for delay or other damages shall submit, within twenty (20) days, a copy of the final bid takeoff, certified pursuant to this subsection. Failure to provide the requested certification shall constitute a forfeiture of the claim for delay or other damages. The certification shall be submitted under oath by a person duly authorized by the claimant and shall contain a statement that:

(a) the final bid takeoff was prepared contemporaneously with the bid and in anticipation of the bid for the project;

(b) the contractor relied on the final bid takeoff to prepare the bid and the original schedule of values; and

(c) the final bid takeoff has not been altered in any way.

(3) Any claim for extended overhead costs that exceeds, on a per diem basis, more than ten percent (10%) of the overhead per diem contained in the final bid takeoff shall be presumed to be a false claim, and the contractor shall have the burden of proving that any such claim for extended overhead is not false.

Section 21-266. Innocent claimant affirmative defense.

The provisions of this ordinance shall not apply if the claimant can demonstrate by a preponderance of the evidence each of the following facts:

(1) the claimant submitted or caused to have submitted the claim to or against the County reasonably believing that such claim was free of any material misstatements, or any exaggerated, inflated, or unsubstantiated assertions or damages;

(2) the claimant had no reasonable basis to doubt the truth, veracity, or accuracy of such claim at the time it was submitted;

(3) prior to submitting the claim, the claimant diligently investigated the facts underlying such claim and prepared the claim in a reasonable manner given all the relevant information available; and

(4) when information indicating that any element, statement, or allegation in the claim was false or misleading first became available, such claimant, within five business days of discovering the falsity of the claim, took immediate steps to modify, correct, or withdraw such claim and provided the County with immediate notice thereof.<<

Section 2. If any section, subsection, sentence, clause, or provision of this ordinance is held invalid, the validity of the remainder of this ordinance shall not be affected by such clause.

Section 3. It is the intention of the Board of County Commissioners, and it is hereby

ordained, that the provisions of this ordinance, including any sunset provision, shall become and be made a part of the Code of Miami-Dade County, Florida. The sections of this ordinance may be renumbered or relettered to accomplish such intention, and the word "ordinance" may be changed to "section," "article," or other appropriate word.

Section 4. This ordinance shall become effective ten (10) days after the date of enactment. Once effective, this ordinance shall apply to (1) all claims submitted to or prosecuted against the County after the effective date hereof, and (2) all claims pending before the County or any court or agency of competent jurisdiction on or after the effective date of this ordinance. As to claims described in subsection (2) of this section that were filed or submitted prior to the effective date hereof, this ordinance shall apply only to such claims after Miami-Dade County provides written notice of this ordinance to the claimant, via certified mail, and allows the claimant a grace period of twenty (20) days to bring its claim into compliance herewith. In such instances, this ordinance shall apply to such claims immediately upon the expiration of the twenty-day grace period.

Section 5. This ordinance does not contain a sunset provision.

PASSED AND ADOPTED: NOV 02 1999

Approved by County Attorney as to form and legal sufficiency:

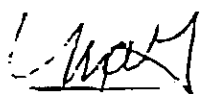

Prepared by:



Sponsored by Commissioner Katy Sorenson and Commissioner Miguel Diaz de la Portilla

## **APPENDIX "G"**

**GENERAL COVENANTS AND CONDITIONS**

**( 39 Pages )**



## GENERAL COVENANTS AND CONDITIONS

### 1. INTENT OF CONTRACT DOCUMENTS

The Questionnaire, the Advertisement for Bids, the Instructions to Bidders, the Proposal, the Certified Resolution (Proposal/Prescribed Bid Bond), the Prescribed Bid Bond, the Contract, the Surety Performance and Payment Bond, the Certified Resolution (Contract/ Surety Performance and Payment Bond), the General Covenants and Conditions, the Supplemental General Conditions (if Ordinance 90-143 is applicable) including Wage and Benefit Schedules, the Specifications, the Plans, any Addenda which may be issued, the Subcontractor /Supplier Listing Form (Ordinance 97-104 as amended by Ordinance 00-30), the Reporting Subcontracting Policies and Procedures (Ordinance 98-15 9), the Community Small Business Enterprise Program (CSBE) Participation Provisions and Forms (if applicable), and the provisions for the following: Affirmative Action Plan (Ordinance 98-30) and Disclosure Form; Bidder's (Debarment) (Ordinance 93-129); Code of Business Ethics (Ordinance 01-96); Criminal Record (Felony) (as amended by Ordinance 00-30); Disability Nondiscrimination (Resolution R-385-95 as amended by Resolution R-182-00); Domestic Violence Leave (Ordinance 99-5 as amended by Resolution R-185-00); Due Fees or Taxes Paid (Ordinance 95-178 as amended by Ordinance 00-30); Metro-Dade Employment Drug-Free Workplace (Ordinance 92-15 as amended by Ordinance 00-30); Metro-Dade Employment Family Leave Plan (Ordinance 91-142 as amended by Resolution R-183-00); Fair Wage (Ordinance 90-143 as amended by Ordinance 95-183); Mandatory Clearinghouse for Posting Notice of Job Opportunities (Resolution R-937-98 as amended by R-1145-99); Obligation (Ordinance 99-162); Office of Miami-Dade County Inspector General (IG) (Ordinance 97-215 as amended by Ordinance 99-151); Sworn Statement - Public Entity Crimes [Florida Statute Sect. 287.133 (3) (a)]; and Metro-Dade County Disclosure (Ordinance 90-133) constitute the Contract Documents. These Contract Documents cover, with explicit provisions, all matters relating to the Project which the Contractor undertakes to effect in full compliance with such provisions. It is understood that the Contractor, by personal examination and inquiry, satisfied himself as to all local conditions and as to the meaning, requirements and reservations of the Contract Documents. No deviation will be allowed from the Engineer's interpretation thereof after the letting.

#### Definitions

"Department" shall mean the Miami-Dade Water and Sewer Department of Miami-Dade County, Florida;

"Director" shall mean the Director of the Miami-Dade Water and Sewer Department;

"Engineer" shall mean the "Assistant Director of Engineering" of the "Engineering Division of the Miami Dade Water and Sewer Department" or such person as the "Assistant Director of Engineering" shall have authorized in writing to act as his "representative";

"Contractor", "Bidder" or "Principal" shall mean the party of the second part to the Contract which holds a current Certificate of Competency applicable to the type of work to be performed, who is primarily liable for the acceptable performance of the work for which he has contracted and also for the payment of all legal debts pertaining to the work;

"Subcontractor" shall mean any person engaged by the Contractor to supply labor, materials or equipment for use in the fulfillment of the Project;

## **GENERAL COVENANTS AND CONDITIONS**

“Substantial Completion” shall occur when the work is in a state of final completion as regards all aspects of occupancy, ingress, egress, habitability, functionality and efficiency thereof, safety, durability and interaction with other existing or contemplated systems, and is otherwise substantially fit for use or operation. Any work remaining after substantial completion shall be of a minor nature such that should the MD-WASD elect to occupy and put into full service the facility constructed under the Project, or any portion thereof, said work may be accomplished without interference to an extent causing loss of efficiency to any of the above required aspects. The date of substantial completion is the date certified by the Architect/Engineer and approved by MD-WASD (if different from the A/E) when construction is sufficiently complete to satisfactorily fulfill all of the above requirements. If any portion of the Contract Documents specifies a particular measure of substantial completion for the work, in whole or in part, that definition shall take precedence of this section.

“Final Completion” shall occur when the work is in a state such that no further work is required in accordance with the Contract Documents to render complete, satisfactory and acceptable to MD-WASD all construction services purchased, including those for any pending items whether or not they were listed after substantial completion, and provide all manuals, certifications, warranties, as-built Plans, release of liens, certified payrolls, and any other documentation required by MD-WASD or other governing authority. If any portion of the Contract Documents specifies a particular measure of final completion for the work, in whole or in part, that definition shall take precedence of this section.

### **Non-Discrimination Or Equal Opportunity**

The “General Contractor”, “vendor”, “contractor,” etc. shall not discriminate against any “Sub-Contractor”, “employee”, “tenant”, “person”, etc. on the basis of race, color, religion, ancestry, national origin, sex, pregnancy, age, disability, marital status, familial status, sexual orientation, gender identity or gender expression, or status as victim of domestic violence, dating violence or stalking.”

## **2. PLANS AND SPECIFICATIONS**

The Plans, Specifications and Addenda thereto, issued prior to receiving bids, describe the Project, and all materials, workmanship and dimensions must be in strict accord with them except only when the Engineer may, in writing, authorize an exception.

In case of conflict between requirements shown on the Plans and provisions of the Specifications, the document imposing the more stringent conditions on the Contractor shall take precedence. Dimensions, shown in figures on the Plans, shall govern in case of any discrepancy between them and scaled dimensions.

All Items shown on the Plans shall be interpreted to be part of the Contract work, and shall be incorporated into the work and included in the bid price.

It is the clear and unequivocal intent of the Department to obtain in the Bidder's Proposal, at the time of bid, a complete price for all work shown or reasonably inferred from the Plans, without utilization of any Allowance Account funds which may or may not be included in the Proposal for any particular project.

The Contractor shall not take advantage of any apparent error or omission which may be

## **GENERAL COVENANTS AND CONDITIONS**

found in the Plans or Specifications, and the Engineer shall be entitled to make such corrections therein and such interpretations as he may deem necessary for the fulfillment of their intent.

The Contractor will be supplied with five copies of the Plans, Specifications and Addenda thereto, and is to preserve them and have at least one copy of them accessible on the job at all times.

### **3. ALTERATIONS IN PLANS AND SPECIFICATIONS**

The right is reserved for the Engineer to make, from time to time, such alterations in the Plans and specifications or in the character of the work or for unseen work or changed conditions which as he may consider necessary or desirable to complete the Project to his satisfaction and consistent with the general intention of the Contract Documents. Notice of every such alteration shall be given in writing to the Contractor, and no such alteration shall be considered as constituting a waiver of any of the provisions of the Contract Documents, or as nullifying or invalidating any of such provisions.

Should any such alteration result in an increase or a decrease in the quantity or cost of work or materials described in the Proposal, the total amount payable under the Contract will be modified accordingly. If alterations are made, the time for completion of the Contract will be correspondingly modified, if the Contractor so requests for the work attributable to such alterations. It is understood that such alterations are not to embrace work already done or materials in transit or in process of construction.

If any alterations or changes, as described hereinabove, results in an increase in the total cost of the Project above that which the Board of County Commissioners approved and as awarded to the Contractor, such alterations or changes will have to be submitted to the Commission for approval, which must be obtained before any work begins. After approval by the Commission, the Engineer will give written notice to the Contractor to proceed with the alterations or changes. Under no circumstances shall the Contractor begin such work until he has received this notification. However if, in the opinion of the Director, the work is of such a critical nature that it cannot be delayed pending approval of the change order by the Board of County Commissioners, the Engineer will give written notice to the Contractor directing him to perform the work without delay and payments will be made in accordance with Section 13 - Extra Work and Payment Therefore. Payment for extra work shall be made upon approval of the change order for this work by the County Commissioners.

### **4. AUTHORITY OF ENGINEER**

The supervision of the execution of this Contract is vested in the Engineer, Construction Manager and his instructions shall be carried into effect promptly and efficiently.

The Engineer shall in all cases determine the amount, quality, fitness and acceptability of the work and materials to be paid for, and shall decide finally and conclusively all questions or differences of opinion that may arise as to the interpretation of the Plans and Specifications or the fulfillment of the terms of the Contract. In the event of such question or difference of opinion, the decision of the Engineer is to be a condition precedent to the Contractor's right to receive any money for the work or the materials to which the question or difference of opinion relates.

## **GENERAL COVENANTS AND CONDITIONS**

If the Contractor considers any work demanded of him to be outside the requirements of this Contract, or if he considers any decision or ruling of the Engineer to be unfair, he shall immediately, upon such work being demanded or such decision or ruling being made, ask for written instructions or decisions, whereupon he shall proceed without delay to perform the work or conform to the decision or ruling. Beginning with the first day of this work, the Contractor and the inspector shall fill out daily records for this work at the end of each day and said record shall be signed by both parties. One copy being submitted to the Engineer and the other being retained by the Contractor. This documentation does not constitute acknowledgment of authorization to pay for this work. In the event that a claim for this work is approved by the Department subsequent to the commencement of work, an accurate accounting for work will be agreed upon by both parties upon completion of this work and will be paid for as work as provided in the Specifications by Allowance Account if funds are available, or by an approved Change Order by the Board of County Commissioners.

The work will be paid for either by a unit price item in the Contract or as extra work for labor, material and equipment which shall be full compensation to the Contractor for all overhead and profit and specified in the General Covenants and Conditions, Section 13, Extra Work and Payment Therefore (a), (b) and (c).

Failure of the Contractor's representatives to meet with the Inspector to maintain daily records for this work shall be deemed that the Contractor does not wish to pursue his claim and has waived all grounds for making a claim.

Unless the Contractor files such written protest with the Director within ten (10) days of receipt said written instructions or decisions, he shall be deemed to have waived all grounds for such protest and to have accepted the requirement, decision or ruling of the Engineer as just and reasonable and as being within the scope of the Contractor's obligations under the Contract Documents and no further documentation will be required by the Department.

No payment for this claim will be made in the event that a timely Contractor's written protest to the Director is formally denied.

The Engineer is to have free access to the materials and work at all times, for laying out, measuring and inspecting the same, and the Contractor is to afford him all necessary facilities and assistance for doing so.

The Engineer of Record shall furnish the Contractor with horizontal and vertical controls which shall be utilized as specified elsewhere herein to layout the work. The Florida Registered Land Surveyor hired by the Contractor shall verify all controls provided by the Engineer of Record and it shall be the responsibility of the Contractor to preserve same.

The Contractor shall retain the services of a Florida Registered Land Surveyor who, shall furnish and set stakes, establishing line and grade and shall solely be responsible for the layout of the work as well as the recording of all as-built dimensions and elevations. The Contractor shall furnish all additional stakes, templates, and other materials for marking and maintaining survey points and lines given, and shall be responsible for their preservation. Should any of the horizontal and vertical control points set by the Engineer of Record be destroyed or disturbed, they shall be reset by the Contractor's Florida Registered Land Surveyor, at the Contractor's expense. All control points previously set by the Engineer of Record shall be verified by the Contractor's surveyor.

## **GENERAL COVENANTS AND CONDITIONS**

For pipeline Projects the Engineer of Record shall furnish the Contractor with horizontal and vertical control every 1,320 feet which shall be utilized as specified elsewhere herein to layout the work. If a pipeline Project is less than 1,320 feet, the Engineer of Record will provide the Contractor with two horizontal and vertical control points. At on-plant-site Projects, the Engineer of Record shall furnish the Contractor with three horizontal and vertical controls.

No direct payment shall be made for the cost to the Contractor of any of the work occasioned by delay in giving lines and grades, or making other necessary measurements, or by inspection.

### **5. AUTHORITY AND DUTIES OF INSPECTORS**

Inspectors, employed by the Department, will be authorized to inspect all work and materials which are to become a part of the completed Project. Inspectors will have no authority to revoke, alter or waive any requirements of the Specifications or to make any changes in the Plans. Each Inspector will be authorized to call the attention of the Contractor to any failure of the work to conform to the Plans or the Specifications, and will have authority to suspend the work affected until any question at issue can be referred to and decided by the Engineer. The Inspector will have no authority to delay the Contractor by failure to inspect the work and materials with reasonable promptness.

### **6. LANDS AND RIGHTS-OF-WAY**

Lands to be furnished by the County for construction operations, roads, or for other purposes, will be specifically shown on the drawings or provided for in the Specifications. Should the Contractor find it necessary to use any additional land for his construction operations or for other purposes during the construction of the work, he shall provide for the use of such lands at his own expense.

Rights-of-way for work to be done under the Contract will be provided by the County. Nothing herein contained, however, and nothing marked on the drawings, shall be interpreted as giving the Contractor exclusive occupancy of the territory provided. When two or more contracts are being executed at one time on the same or adjacent land in such a manner that work on one contract may interfere with that on another, the Engineer will decide which Contractor shall cease work, and which shall continue, or whether the work of both contracts shall progress at the same time, and in what manner. When the territory of one contract is a necessary or convenient means of access for the execution of another contract, the Engineer may grant to the Contractor so desiring such privilege of access to the territory as the Engineer shall deem to be appropriate, and no such decision shall be made the basis of any claim for delay or damage, except as provided in Section 11 herein.

### **7. MATERIALS, LABOR AND EQUIPMENT**

The Contractor shall furnish all necessary tools and construction equipment and shall employ sufficient and competent personnel to do the work in an expeditious and acceptable manner, giving preference whenever practicable to residents of Dade County, Florida. In the event that the Engineer shall notify the Contractor in writing that any person employed is, in the opinion of the Engineer, incompetent or disorderly, or uses threatening or abusive language, or is otherwise unsatisfactory, such person shall be discharged at once and shall not be employed thereafter on the work.

## **GENERAL COVENANTS AND CONDITIONS**

The Contractor shall furnish all materials used in the construction of the Project and all equipment becoming a part of the Project, unless such materials or equipment are specifically stated in the Specifications as being furnished by the Department. In the latter case, only the cost of installation of such materials or equipment shall be included in the Contract price. The Department retains ownership of any materials or equipment it furnished which are not incorporated in the work, and if no longer needed on the job, the Contractor shall remove the items promptly. The Contractor, at his own expense, shall load such materials or equipment at the work site, transport them to Department storage yards as directed by the Engineer, and shall unload and leave them neatly stored in a workmanlike manner.

Where the Plans and Specifications designate the product of a particular manufacturer, the product specified is suitable for the intended use, but unless otherwise provided, articles or products of similar characteristics may be offered for the approval of the Engineer.

### **8. RESPONSIBILITY OF THE CONTRACTOR**

The Contractor shall have at all times, as his agent on the site of the work, a competent superintendent capable of reading and thoroughly understanding the Plans and Specifications. The Superintendent shall have full authority to supply promptly such materials, tools, plant equipment and labor as may be required.

The Contractor shall be responsible for the good condition of the work or materials until formal release from his obligations under the terms of his Contract. The Contractor shall store materials and shall be responsible for and shall maintain partly or wholly finished work during the continuance of the Contract. If any materials or part of the work be lost, damaged, or destroyed by any cause or means whatsoever, the Contractor shall satisfactorily repair and replace the same at his own cost. He shall bear all losses resulting to him on account of the amount or character of the work, or the character of the ground, being different from what he anticipated, or on account of the weather or the elements. He shall place sufficient lights and danger signals on or near the work from sunset to sunrise; shall erect suitable railings or other protective devices about unfinished work, open trenches, embankments, or other obstructions; shall provide all necessary watchmen on the work by day or by night for the safety of the public, and shall take all necessary precautions for preventing accidents or injuries to persons or property in or about the work.

In the event that the Contractor plans or his subcontractors plan to enter into subcontracts for any portion of the Project, he and they shall incorporate in each such subcontract all provisions, terms and conditions applicable to the Project which constitute obligations to be assumed and effected by the Contractor under the Contract Documents, and shall submit a copy of each such subcontract at all tiers to the Engineer for examination and approval prior to his or their execution of the subcontract. Each individual contract shall be submitted with all provisions and all payment details clearly stated and included. Generalized contracts or contracts without all details/provisions included will not be acceptable. Subcontracts shall be entered into only with those subcontractors so approved in writing by the Engineer. The County reserves the right of approval or rejection to any subcontract at any tier contemplated by the Contractor or his subcontractors at any tier for any portion of the Project, whichever it deems to be in its best interest.

The Contractor hereby agrees to perform the work under this Contract as an independent Contractor, and not as a subcontractor, agent or employee of the County.

## **GENERAL COVENANTS AND CONDITIONS**

The Contractor hereby agrees to familiarize himself with all codes and regulations of the Federal Government, the State of Florida, the County of Miami-Dade and any municipal corporations applicable to every aspect of the Project. The Contractor shall provide all materials and shall perform all work necessary to fully comply with all provisions and requirements of applicable codes, regulations and permits whether specifically indicated in the Plans and Specifications or not. It is the intent of the Department to obtain a finished Project in full compliance with all requirements of any agencies having jurisdiction over any portion of the work involved in the Project. The Engineer will not recommend acceptance of the work until all requirements and provisions of pertinent codes and regulations have been satisfactorily fulfilled.

The County may retain from money otherwise payable under the Contract such amount as it may determine to be required to pay the expenses and damages arising from any of said causes or in case no money is due, the Contractor's surety shall be held until such suits, action or claims for injuries or damages shall have been settled and suitable evidence to that effect furnished to the County.

The Contractor shall at all times conduct the work in such manner and in such sequence as will insure the least practicable local interference. He shall not open up work to the prejudice of work already started, and the Engineer may require the Contractor to finish a section on which work is in progress before work is started on any additional section.

The Contractor shall arrange his work and dispose of his materials so as not to interfere with the operations of other contractors engaged upon adjacent work, shall join his work to that of other contractors in a proper manner and in accordance with the spirit of the Plans and Specifications, and shall perform his work in the proper sequence in relation to that of other contractors, all as may be directed by the Engineer.

The Department reserves the right to interview and approve the Contractor's supervisor and the supervisors of the Contractor's subcontractors, at any tier, to be employed in the supervision of the work of this Contract. The Department may withhold approval of a subcontractor until the subcontractor's supervisor is approved by the Engineer. The Contractor and subcontractor's supervisor must provide satisfactory proof of his experience and special ability to perform the work to be accomplished under the subcontractor.

If the Contractor or his subcontractors intends to remove a supervisor previously approved by the Department to perform the supervision of the work specified in this Contract, any replacement of a supervisor is subject to approval of the Department. Any critical personnel, as determined by the Department, shall be continued in their engagement by the Contractor and not replaced except as approved by the Department in accordance with the provisions and intent of Resolution R744-00.

### **9. INFORMATION AND DRAWINGS TO BE FURNISHED BY THE CONTRACTOR**

Before proceeding with the erection of his construction plan, including the setting or placing thereof, and the erection of other temporary structures, the Contractor shall furnish the Engineer with such information and drawings as the Engineer may require.

The Contractor shall furnish such cost breakdowns as required by the Engineer, including a detailed estimate giving a complete breakdown of the Contract price and a breakdown of the cost of various portions of the work for use in preparing monthly estimates and for allocating

## **GENERAL COVENANTS AND CONDITIONS**

costs in the classified property accounting system of the Department. The cost breakdowns shall be physical items with mobilization, bond, patent fees and royalties, insurance, home office expenses, overhead, and all other general costs and profits, prorated to each physical item. No payment will be made to the Contractor until these breakdowns are submitted in a form satisfactory to the Engineer.

The Contractor shall furnish for review and approval by the Engineer the number of copies of shop drawings specified in the Contract Documents. Where that number is not specified in the Contract Documents, no less than six copies shall be submitted. In the case of differing numbers of shop drawings being provided for elsewhere in the Contract Documents, the larger number shall prevail unless otherwise ordered by the Engineer. Submittal of shop drawings shall be made so as to allow sufficient time for the ordering and fabrication of special order or long lead items or construction use of any standard element of the work.

It is the Contractor's sole responsibility upon the first occasion of submittal of a particular element of the work, to submit shop drawings of an element which match and fulfill the requirements and intent of the Plans and Specifications. Any delays or costs caused, either directly or indirectly, by non-timely submissions; submission of items differing significantly from the intent of the Plans and/or Specifications; repeated submission of, or argument over, rejected elements or changes required for acceptance; arguments with the criteria or requirements of the Plans or Specifications; or any other such similar activities shall be at the sole expense of the Contractor. It is the intent of the Contract Documents that the Contractor shall, in the first instance, submit shop drawings of elements which meet or exceed the requirements of the Contract Documents and fit with the other elements of the work and the existing conditions. Activities such as those mentioned above, which are inimical to this intent will not be tolerated and may, at the sole discretion of the Engineer, subject the Contractor to costs for any delays, costs, damages or penalties suffered by County due to such activities to include but not be limited to; extra engineering and overhead costs together with any liquidated or actual damages.

Shop drawings shall be of such character that they may be used as fabrication drawings. Prior to submission, the Contractor shall thoroughly check such drawings, satisfying himself that they meet the requirements of the Plans and Specifications and that they are coordinated with the arrangements set forth on other shop drawings, and shall place on them the Contract Number, the date and his stamp of approval. Where items for which shop drawings are submitted are to meet special conditions listed in the detailed Specifications, the conditions shall be so noted on the drawing. Where there is a deviation from the Specifications, the Contractor shall note it and state the reason why a deviation is required. Two copies will be returned to the Contractor with the Engineer's mark of approval thereon, or will be marked to indicate changes necessary to effect compliance with the Specifications and the remaining copies will be retained by the Department. When drawings are approved by the Engineer, they shall be as binding as any of the Contract Documents. Any errors or omissions on the shop drawings shall not relieve the Contractor of his responsibility. He shall correct such errors, or omissions, including any necessary additions or alterations to construction, at his expense upon notification by the Engineer.

### **10. COMPLIANCE WITH APPLICABLE LAWS**

The Contractor shall comply in every respect with all applicable laws, regulations and building and construction codes of the Federal Government, the State of Florida, the County of Dade, and any municipal corporation within the boundaries of which any of the work is to be done, and shall obtain all such occupational licenses and permits as shall be prescribed by law.



## **GENERAL COVENANTS AND CONDITIONS**

The attention of the Contractor is hereby directed to the requirements of the Code of Miami-Dade County, Chapter 489 of the Florida Statutes, and the rules of the State of Florida Department of Professional Regulation, governing the qualifications for Contractors and subcontractors doing business anywhere in the County, and further is directed to the license requirements of the various municipalities located within Miami-Dade County prerequisite to the issuance of permits to contractors and subcontractors within the corporate limits of such municipalities.

The attention of the Contractor is also hereby directed to the requirements of Section 2-11 and 2-11.1 of the Code of Metropolitan Dade County, Florida, entitled "Outside Employment by County Employees" and "Conflict of Interest and Code of Ethics Ordinance", respectively.

All successful bidders/respondents on County contracts in which subcontractors may be used shall be subject to and comply with Ordinance 97-35 as amended, requiring bidders/respondents to provide a detailed statement of their policies and procedures for awarding subcontracts which:

- a) notifies the broadest number of local subcontractors of the opportunity to be awarded a subcontract;
- b) invites local subcontractors to submit bids in a practical, expedient way;
- c) provides local subcontractors access to information necessary to prepare and formulate a subcontracting bid;
- d) allows local subcontractors to meet with appropriate personnel of the bidder to discuss the bidder's requirements; and
- e) awards subcontracts based on full and complete consideration of all submitted proposals and in accordance with the bidder's stated objectives.

All bidder/respondents seeking to contract with the County shall, as a condition of award, provide a statement of their subcontracting policies and procedures. Bidders/respondents who fail to provide a statement of their policies and procedures may not be recommended by the County Manager for award by the Board of County Commissioners.

In accordance with Ordinance No. 97-104, as amended by Ordinance 00-30, all successful bidders and respondents on County contracts for purchase of supplies, materials or services, including professional services, which involve the expenditure of \$100,000 or more and all successful bidders or respondents on County or Public Health Trust construction contracts which involve the expenditure of \$100,000 or more and where the specifications do not expressly preclude the use of subcontractors shall provide, as a condition of award, a listing which identifies all first tier subcontractors who will perform any part of the Contract work and describes the portion of the work such subcontractor will perform, and all suppliers who will supply materials for the Contract work direct to the bidder or respondent and describes the materials to be so supplied.

Ordinance 97-104, as amended, applies to all contracts whether competitively bid by the County or not. Those contracts that have received authorization by the Board of County Commissioners to waive formal bidding procedures must also provide a listing of all first tier subcontractors and direct suppliers.

'Subcontractor/Supplier Listing, SUB Form 100' may be utilized to provide the information required by this paragraph. A successful bidder or respondent who is awarded the Contract

## **GENERAL COVENANTS AND CONDITIONS**

shall not change or substitute first tier subcontractors or direct suppliers or the portions of the Contract work to be performed or materials to be supplied from those identified in the listing submitted except upon written approval of the County.

In accordance with Dade County Resolution Number 9601, the Contractor agrees to make no discrimination because of race, color, creed or national origin with respect to employment of personnel on this Project, and that all persons having the experience and skill necessary to perform the work shall be afforded equal opportunity of employment for the work to be performed at the site of this Project.

In accordance with Section 2-8.1 of the Miami-Dade County Code, as amended by Ordinance 00-30 (copies of both attached), award of this Contract is conditioned on the Contractor providing the County with a listing of first tier subcontractors and direct suppliers to be used in performance of the work of the Contract, if subcontractors and suppliers are required.

In accordance with Section 2-8.1 of the Miami-Dade County Code, as amended by Ordinance 01-96 (copies of both attached), award of this Contract is conditioned on the Contractor adopting a Code of Business Ethics prior to entering into a Contract with Miami-Dade County; providing that failure to comply with the Code of Business Ethics shall render the Contract voidable and empowering the Miami-Dade Inspector General to investigate alleged violations of the Code of Business Ethics.

In accordance with Section 2-8.1.2 of the Miami-Dade County Code, as amended by Ordinance 00-30 (copies of both attached), award of this Contract is conditioned on the Contractor certifying to the County that the Contractor does not owe, or is delinquent to the County in making payment of any fee, tax, contractual debt, or loan. The County may debar contractors who fail to comply with this section.

In accordance with Section 2-8.6 of the Miami-Dade County Code, as amended by Ordinance 00-30 (copies of both attached), award of this Contract is conditioned on the Contractor providing a drug free workplace. The County may debar a contractor who fails to provide a drug free workplace. Specific requirements relating to provision of a drug free workplace are detailed in Section 35 of these General Covenants and Conditions.

In accordance with Section 10-34 of the Miami-Dade County Code, as amended by Ordinance 00-30 (copies of both attached), award of this Contract is conditioned on the Contractor providing the County notice of any felony conviction during the past ten years against the Contractor, or against any officer, director, or executive of the Contractor. The County may debar a Contractor who fails to comply with the provisions of the section.

In accordance with Resolution R-182-00, which amended R-385-95, the Contractor shall comply with the American with Disabilities Act of 1990 and other laws prohibiting discrimination on the basis of disability requirements as a requirement of award. Failure to comply with the requirements of Section 3 of Resolution R-385-95, as amended, may result in debarment of those who knowingly violate this policy or falsify information. (Copy of R-182-00 appended at rear of specifications.) Violation of any act or law cited in R-182-00 renders this Contract voidable by the County.

In accordance with Resolution R-183-00, bidders or proposers covered by the County's

## GENERAL COVENANTS AND CONDITIONS

Family Leave Ordinance shall, as a condition of award, certify that they provide family leave to their employees as required by such ordinance. The obligation to provide family leave to their employees shall be a contractual obligation. Failure to comply with the requirements of Section 2 of Resolution R-1499-91, as amended, may result in debarment. (Copy of R-183-00 appended at rear of specifications.)

In accordance with Resolution R-185-00, prior to entering into a contract with the County, the Contractor shall, as a condition of award, certify that the firm is in compliance with the Domestic Leave Ordinance, Ordinance 99-5. The obligation to provide domestic violence leave to their employees shall be a contractual obligation. Failure to comply with requirements of R-185-00 as well as the Domestic Leave Ordinance may result in the Contract being declared void, the Contract being terminated and/or the firm being debarred. (Copy of R-185-00 appended at rear of specifications.)

The Contractor shall fully comply with the provisions of: Ordinance 99-152, the False Claims Act; Ordinance 99-162, 00-67 and their Administrative Order which prohibit contracting with individuals and entities that are in arrears to the County; Ordinance 00-66 relating to restoration after construction of utilities or works in the public right of way; and Ordinance 00-97 relating to protection of underground utilities and requiring various Contractor activities; Resolution R-744-00, relating to retention in service of critical personnel. The County has adopted via Resolutions R749-00 and R161-01 a "Business Road Impact Assistance Loan Program". The Contractor shall make every effort to minimize construction impact to business in the area of the Project and as appropriate, the Department will recover any costs caused the County by Contract delays or other business impacting activities attributable to the Contractor. To this end the Contractor shall conduct its construction activities in a manner that will minimize these detrimental effects.

The attention of the Contractor is directed to Miami-Dade County 99-152, which prohibits the presentation, maintenance, or prosecution of false or fraudulent claims against the County. By terms of the ordinance, the Contractor is prohibited from:

- a) knowingly presenting or causing to be presented to the County or to any officer or employee, agent, or consultant of the County, a false or fraudulent claim for payment,
- b) knowingly making, using, or causing to be made or used, a false record or statement to get a false, fraudulent, or inflated claim paid or approved by the County,
- c) conspiring to defraud the County by facilitating the payment of a false, fraudulent, or inflated claim allowed or paid by the County,
- d) delivering, with the intent to defraud the County, goods or services of different quality or quantity than that specified in the applicable contract or specifications,
- e) making or delivering the document certifying receipt of property used, or to be used by the County, without completely knowing that the information on the receipt is true,
- f) knowingly buying or receiving as a pledge of an obligation or debt, public property from an officer, employee, or agent of the County who lawfully may not sell or pledge the property, and
- g) knowingly making, using, or causing to be made or used, a false record or statement to conceal, avoid, or decrease an obligation to pay or transmit money or property to the County.

## GENERAL COVENANTS AND CONDITIONS

A Contractor who violates the terms of this ordinance may be subjected to criminal prosecution, civil penalties, including treble damages, or debarment, and shall be liable to the County for all costs in and fees incurred by the County to defend, review, and evaluate the claim; these penalties are cumulative. Violation of this ordinance shall in addition result in the forfeiture of the entire claim made by the Contractor.

Pursuant to this Ordinance, the County may ask that the Contractor certify a claim made to the County. A certified claim must be made under oath by a person duly authorized by the claimant, and shall state:

- a) the claim is made in good faith,
- b) that the data supporting the claim are accurate and complete to the best of the person certifying the claim's knowledge and ability,
- c) that the amount of the claim accurately reflects the amount that the claimant believes is due from the County, and,
- d) that the certifying person is duly authorized to certify the claim.

Failure to provide the requested certification shall result in forfeiture of the claim. Where the document to be certified is the final bid takeoff, that certification shall be made under oath by a person authorized to certify the takeoff and shall state that:

- a) the final bid takeoff was prepared contemporaneously with the bid and in anticipation of the bid for the Project,
- b) that the Contractor relied on the final bid takeoff to prepare the bid and the original schedule of values, and
- c) that the final bid takeoff has not been altered in any way.

A Contractor making a claim against the County for delay or other damages must submit, within twenty days, a certified copy of the final bid takeoff, if so requested by the County. Failure to submit the certified final bid takeoff shall result in forfeiture of the claim for delay or other damages. The final bid takeoff shall be the final estimate, tabulation, or worksheet prepared by the bidder in anticipation of the bid submitted, and shall both reflect the final bid price and contain a line item for overhead costs.

Compliance with all of the above-designated regulations is mandatory.

### 11. CONSTRUCTION SCHEDULE, TIME OF PERFORMANCE AND LIQUIDATED DAMAGES

Immediately after receipt of the Notice to Proceed and prior to the actual start date, the Contractor shall deliver to the Engineer for review, in a form satisfactory to the Engineer, a construction progress schedule, showing dates of commencement and completion of each of the various subdivisions of the Project and a schedule of material delivery dates to be incorporated into each phase of the work as set forth in the Specifications. Within five days of receipt of said schedule, the Engineer shall meet with the Contractor for a joint review. The Contractor shall submit six copies of the corrected schedule at the preconstruction meeting for discussion and approval. The Engineer may require the corrected schedule prior to said pre-construction meeting.

The Contractor shall begin the Project with an adequate force and sufficient equipment

## GENERAL COVENANTS AND CONDITIONS

and facilities on the date stated in the written notice issued and served upon him by the Engineer. Thereafter, the Contractor shall prosecute the work diligently, without any avoidable interruption and at such rate and with such complement of labor, materials and equipment as will complete the Project within the time stated in the Proposal.

The Contractor shall establish a schedule based on an eight hour work day with one hour for lunch and provide this schedule to the Engineer. Overtime inspection fees are applicable as established in Section 43 Standard Work Hours and Construction Management Overtime of the General Covenants and Conditions.

No work, however, shall be done between outside of standard work hours, except such work as is authorized by the Engineer or is necessary for the proper care and protection of the work already performed, or except in case of an emergency, in which event the permission of the Engineer to do such work shall be secured.

### Liquidated Damages

**The Liquidated Damages for this project shall be set at \$1,000 per day Sundays and Holidays included.** The County and the Contractor agree that it is impossible, at the time this Contract is executed, to ascertain the precise amount of damages which the County may suffer as a result of any compensable delay, and that proof of such damages will be difficult. Since time is of the essence of this Contract, in the event that the work to be done hereunder is not completed within the times hereinbefore specified (and such additional extension of time as the Engineer may have granted), the County will retain from the compensation otherwise to be paid to the Contractor, including partial payments as defined in Section 28 herein, the County and the Contractor agree that the sum of one thousand dollars (\$1,000.00) for each day thereafter (Sundays and holidays included) that the work remains uncompleted, which sum is a fair and reasonable sum for all indirect costs as may be borne by the County due to the Contractor exceeding the Construction Time of the Contract and represents the actual damages which the County will have sustained per day by failure of the Contractor to complete the work within said specified times, it being agreed that said sum is not a penalty but is the stipulated amount of damage sustained by the County in the event of such default by the Contractor.

The provisions of the Supplemental General Conditions (If Ordinance 90-143 is applicable to this Contract) setting forth liability for unpaid wages, penalties, and for withholding, are all in addition to the damages specified hereinabove.

Should a delay in the work be caused by an act of God, war, strike action of the county or other cause beyond the control of the Contractor, the Contractor may make a written request within **five calendar days** of the commencement of the delay, for a non-compensable Contract time extension. Pursuant to such request, a non-compensable time extension will be granted if, in the opinion of the Engineer, the claim is justified. The Engineer's decision shall be final. The Engineer shall not consider delays caused by late delivery of equipment or material to be beyond the control of the Contractor and hence shall not allow an extension of time for them unless written evidence is furnished that they were caused by acts of God, war, strikes or action of the County. Inclement weather will not be a justifiable claim.

## 12. INSURANCE TO BE CARRIED BY CONTRACTOR AND INDEMNIFICATION

Prior to execution of the Contract by the County and commencement of work, the

## GENERAL COVENANTS AND CONDITIONS

Contractor shall obtain all insurance required under this Section and submit same to the County for approval. All insurance shall be maintained until work has been completed to the status specified below.

The Contractor shall furnish to Miami Dade Water and Sewer Department - 3071 S.W. 38<sup>th</sup> Avenue, Miami, FL 33146-2221, Certificate(s) of Insurance which indicate that insurance coverage has been obtained which meets the requirements as outlined below:

- a) Worker's Compensation Insurance - as required by Chapter 440, Florida Statutes and, where applicable, coverage for the U.S. Longshoremen's and Harbor Worker's Act and the Jones Act.
- b) Commercial General Liability in an amount not less than \$1,000,000.00 per occurrence for Bodily Injury and Property Damage combined single limit per occurrence. Insurance shall include coverage for Explosion, Collapse & Underground Hazards. **Miami-Dade County must be shown as an additional insured with respect to this coverage.**
- c) Automobile Liability Insurance - covering all owned, non-owned and hired vehicles used in connection with the work, in an amount not less than \$1,000,000.00 per occurrence for Bodily Injury and Property Damage combined single limit per occurrence.
- d) When so required in the Instructions To Bidders, the Contractor shall procure and shall maintain until work has been completed to the status specified below, complete Value Builders' Risk / or Installation Floater Insurance - covering perils on an "All Risks" basis, including windstorm, in an amount of not less than one hundred percent of the **contract value** of the building(s) or structure(s). The policy shall be in the names of the County and Contractor, as their interests may appear. **Installation floater insurance will not be required on any projects composed of solely pipeline work.**

The Public Liability Insurance coverage as required in paragraph b) above shall include those classifications, as listed in Standard Liability Insurance Manuals, which are applicable to the operations of the Contractor in the performance of this Contract.

All insurance policies required above shall be issued in companies authorized to do business under the laws of the State of Florida, with the following qualifications:

The Company must be rated no less than "A-" as to management, and no less than "Class VII" as to strength, by the latest edition of Best's Insurance Guide, published by A. M. Best Company, Oldwick, New Jersey, or its equivalent, subject to the approval of the County Risk Management Division.

Or

The Company must hold a valid Florida Certificate of Authority as shown in the latest "List of All Insurance Companies Authorized of Approved to Do Business in Florida" issued by the State of Florida Department of Financial Services.

The Contractor shall furnish Certificates of Insurance to the County prior to commencing any operations under this Contract, which certificates shall clearly indicate that the Contractor has obtained insurance, in the type, amount and classifications, in strict compliance with this

## **GENERAL COVENANTS AND CONDITIONS**

Section. All insurance required by the Contract shall stay in force until construction of the Project is complete to a point where no construction personnel of the Contractor or any subcontractor are required to be on the site of the work and all survey work for as-built drawings is completed to the satisfaction of the Engineer. At that point the Contractor shall make written request to the Engineer to discontinue all or portions of the insurance coverage for the Project (as appropriate) and upon receipt of written permission from the Engineer may discontinue said insurance. In any instance where work must be resumed after a pause, the Contractor shall obtain all insurance as required above prior to performing the work.

NOTE: See the Instruction to Bidders for any modifications to these insurance requirements.

Certificates will indicate that no modification or change in insurance shall be made without thirty (30) days advance notice to the certificate holder.

NOTE: **MIAMI DADE COUNTY CONTRACT NUMBER AND TITLE OF CONTRACT MUST APPEAR ON EACH CERTIFICATE AND POLICY.**

**CERTIFICATE HOLDER MUST READ: MIAMI-DADE COUNTY  
111 N.W. 1<sup>ST</sup> STREET  
SUITE 2340  
MIAMI, FL 33128**

Compliance with the foregoing requirements shall not relieve the Contractor of his liability and obligation under this section or under any other section of this agreement.

The Contractor shall indemnify and hold harmless the County and its officers, employees, agents, consultants and instrumentalities from any and all liability, losses or damages, including attorneys' fees and costs of defense, costs of patent rights and fees, which the County or its officers, employees, agents, consultants or instrumentalities may incur as a result of claims, demands, suits, causes of actions or proceedings of any kind or nature arising out of, relating to or resulting from the negligence, recklessness, or intentional wrongful misconduct of the Contractor or its employees, agents, servants, partners, principals or subcontractors in the performance of this Contract. The Contractor shall pay all claims and losses in connection therewith and shall investigate and defend all claims, suits or actions of any kind or nature in the name of the County, where applicable, including appellate proceedings, and shall pay all costs, judgements, and attorneys' fees which may issue thereon. The Contractor expressly understands and agrees that any insurance protection required by this Contract or otherwise provided by Contractor shall in no way limit the responsibility to indemnify, keep and save harmless and defend the County or its officers, employees, agents, consultants and instrumentalities as herein provided.

The Contractor agrees to defend against any claims brought or action filed against the County, the Engineering Consultants, or their officers, agents and employees in connection with the subject of the indemnities contained herein.

### **13. EXTRA WORK AND PAYMENT THEREFORE**

The Contractor shall perform extra work, for which there is no price included in the

## **GENERAL COVENANTS AND CONDITIONS**

Proposal, wherever it is deemed necessary or desirable by the Engineer to complete satisfactorily the Project as contemplated, and such extra work shall be performed promptly in accordance with the Specifications and as directed by the Engineer; provided, however, that before any extra work is begun, a written order from the Engineer to do the work shall be given to the Contractor. No extra work will be paid for unless ordered in writing.

Extra work, for a complete job, will be paid for in a lump sum or at unit prices agreed to in writing by the Engineer and the Contractor before the extra work is ordered for performing the work. Payment for lump sum work shall be based on the following:

The Contractor shall submit to the Engineer an estimated proposal containing a complete breakdown of costs to perform the work to which shall be added an amount equal to fifteen percent of such sum for labor and the total thereof shall be full compensation to the Contractor for performing the work which includes overhead and profit, home office expenses for general supervision and for furnishing and repairing small tools and ordinary equipment used in doing the extra work. In addition, the Contractor shall include the cost of social security taxes, unemployment insurance, worker's compensation, fringe benefits, inclusive of life and health insurance, union dues, pension, pension plans, vacations, and insurance and Contractor's public liability and property damage insurance involved in such extra work, based on the wages paid to such labor.

For all materials used, the Contractor shall include the estimate cost of such materials, including freight charges, to which cost shall be added an amount equal to ten percent thereof, for full compensation which includes overhead, profit and home office expenses.

For any construction equipment or special equipment including fuel and lubricant, required for the economical performance of extra work, the Engineer shall pay the Contractor a rental price, for every hour that such construction equipment or special equipment is estimated to operate on the work. This provision is intended to pay for heavy or special construction equipment; the County shall therefore not pay for small tools and equipment ordinarily used in construction. Where there is a question as to whether payment pursuant to this section is valid the Engineer shall make the final determination as to the validity of such payment. The hourly rental price of such construction or special equipment shall not exceed 1/176 part of the monthly rate stated for such equipment in the latest edition of the "Compilation of Rental Rates for Construction Equipment" by Associated Equipment Distributors. In the event that the equipment is not owned by the Contractor or his companies and the equipment is rented from a recognized equipment rental company, the Contractor will be paid the estimated time that the equipment will work at the hourly rental rate to which shall be added ten percent for fuel, maintenance and lubrication for rented equipment.

The Contractor is required to include a statement certifying that this claim is justified and that it is consistent with the Plans and Specifications and he has reviewed all the costs for extra work and has found them to be accurate, fair and reasonable. If extra work is ordered, it shall be included in the Contractor's monthly estimate when Allowance Account funds are available in the Contract for the work actually done. If no allowance account funds are available a change order will be issued.

The performance of any extra work or the furnishing of any extra material which, in the judgement of the Engineer, is of like character to and susceptible of classification under a unit price item of the Contract shall, if the order of the Engineer shall so provide, be paid for at the



## GENERAL COVENANTS AND CONDITIONS

unit price bid for such item or items, where Allowance Account funds are available in the Contract with the Contractor's monthly estimate, for the work actually done.

All extra work performed hereunder will be subject to all of the provisions of the Contract. Whenever, in the judgment of the Engineer, such extra work or such extra material is not of like character to and susceptible of classification under a unit price item of the Contract, or the application of the unit price will result in unacceptably high costs to the Department, and it is impracticable because of the nature of the work, or for any other reason, to fix the price before the extra work order is issued, extra work and material will be paid for in the following manner:

- (a) For all labor, including a working foreman in direct charge of the specified operations, the Contractor shall receive a sum equal to the current local rate of wages for every hour that the labor is actually performed. For a working foreman who performs labor, the Contractor may charge one hundred percent of his hourly wage rate; for a foreman who only directs workers in the performance of their work, the Contractor may charge the following: twenty-five percent of the working foreman's salary for directing up to two workers in their work; fifty percent of sum salary for directing up to four workers in their work; seventy five percent for directing five workers in their work; and one hundred percent for directing six workers or more in their work, to which shall be added an amount equal to fifteen percent of such sum, and the total thereof shall be full compensation to the Contractor for performing the work which includes overhead and profit, home office expenses, general supervision and for furnishing and repairing small tools and ordinary equipment used in doing the extra work. In addition, the Contractor shall be paid the actual cost of social security taxes, unemployment insurance, worker's compensation, fringe benefits, inclusive of life and health insurance, union dues, pension, pension plans, vacations, and insurance and Contractor's public liability and property damage insurance involved in such extra work, based on the actual wages paid to such labor.
- (b) For all materials used, the Contractor shall receive the actual cost of such materials, including freight charges as shown by original receipted bills, to which cost shall be added an amount equal to ten percent thereof, for full compensation which includes overhead, profit and home office expenses.
- (c) For any construction equipment or special equipment including fuel and lubricants, required for the economical performance of extra work, excluding the small tools and ordinary equipment as specified above, the Engineer shall allow the Contractor a rental price, to be agreed upon in writing before such work is begun, for every hour that such construction equipment or special equipment is actually operated on the work. Such hourly rental price shall not exceed 1/176 part of the monthly rate stated for such equipment in the latest edition of the "Compilation of Rental Rates for Construction Equipment" by Associated Equipment Distributors. In the event that the equipment is not owned by the Contractor or his companies and the equipment is rented from a recognized equipment rental company, the Contractor will be paid for every hour that the equipment is actually working at the hourly rental rate to which shall be added ten percent for fuel, maintenance and lubricants for rented equipment.

The Contractor's representative and the Inspector shall compare records of extra work done at the end of each day. Such records shall be made in duplicate upon a form provided for

## **GENERAL COVENANTS AND CONDITIONS**

such purpose by the Inspector, and shall be signed by both the Inspector and the Contractor's representative, one copy being submitted to the Engineer and the other being retained by the Contractor.

All claims for extra work done shall be submitted by the Contractor upon certified statements, to which shall be attached the original receipted bills covering the costs of and freight charges on all materials used in such work, and such statements, accompanied by copies of the orders authorizing the performance of the work, shall be submitted to the Engineer for inclusion in the estimate of the month in which the work was actually done, where allowance account funds are available in the contract. If no allowance account fund is available, the extra work shall be paid for, subject to approval of a change order for this work, by the Board of County Commissioners.

If required, the Contractor shall produce any books, vouchers, other records, or memoranda which will assist the Engineer in determining the true, necessary cost of work and materials to be paid for on a cost plus basis.

In the event that the Contractor employs a subcontractor to perform his extra work for any portion of the lump sum work, or for any portion of extra work, material or equipment as described in Section 13 (a), (b) or (c), the Contractor may charge an additional ten percent for his full compensation for overhead, profit, home office expenses and general supervision for this portion of work performed by the subcontractor.

The subcontractor must comply with all the requirements of the Contract for his portion of extra work and be compensated as permitted for this extra work.

No additional compensation will be paid for overhead, profit, home office expenses or supervision to any subcontractors working for subcontractors.

In no case will the Contractor be entitled to compensation pursuant to this Section unless the Contractor has first provided notice, as describe in Section 4 of the General Covenant and Conditions that the work is outside the requirements of the Contract, unless the work is denominated by the Engineer in writing as extra work pursuant to Section 3 of the General Covenants and Conditions.

No additional compensation shall be due the Contractor for extra work occasioned as a result of differing site conditions, or as a result of delays, except to the extent specified in Sections 14 and 15 of the General Covenants and Conditions. If the Contractor believes that an order or directive of the Engineer calls for the performance of work outside the requirements of the Contract, the Contractor shall so notify the Engineer in accordance with Section 4 of the General Covenants and Conditions.

### **14. TIME EXTENSIONS AND DELAY**

Where the progress of the Contractor is delayed, and such delay is beyond the control of the Contractor, and if such delay affects the critical path of the Project, the Contractor shall, within five days of the start of the delay, notify the Engineer in writing of the delay and requesting an extension of the Contract time. Said notice shall specifically detail the nature and cause of the delay and shall include sufficient and credible and complete documentation, to include but not limited to approved schedules, to allow the Engineer to evaluate the impact of

## **GENERAL COVENANTS AND CONDITIONS**

the delay on the Contractor's critical path. If the Engineer finds that the delay is beyond the control of the Contractor and affects the critical path of the Project, the Engineer will grant the Contractor a non-compensable time extension, assuming sufficient time remains in the allowance account for this project. If no time remains in the allowance account, time shall not be granted except with the authorization of the Board of County Commissioners.

Proper and timely notification to the Engineer of the delay, as provided for above, is a condition precedent to any obligation on the part of the County to grant a non-compensable time extension, and the failure of the Contractor to properly and timely render such notice shall serve as a bar on the maintenance or litigation of any claim related for additional time arising out of the delay, and shall serve as a waiver by the Contractor of any and all such claims.

A non-compensable time extension shall be the sole remedy available to the Contractor for delays beyond the control of the Contractor. IN NO EVENT SHALL A CLAIM FOR DAMAGES OR ANY CLAIM OTHER THAN FOR AN EXTENSION OF TIME BE MADE OR ASSERTED AGAINST THE COUNTY BY REASON OF ANY DELAYS. The Contractor shall not be entitled to an increase in the Contract Sum of payment of compensation of any kind from the County for direct, indirect, consequential, impact or other costs, expenses or damages, including but not limited to costs of acceleration or inefficiency, arising because of delay, disruption, interference or hindrance from any cause whatsoever; provided, however, that this provision shall not preclude recovery or damages, in the liquidated amount specified herein, by the Contractor as available in law through a court of competent jurisdiction for hindrances of delays caused solely by the bad faith, fraud, or active interference of the County or its agents. Otherwise, the Contractor shall be entitled only to non-compensable extension of the Contract Time as the sole and exclusive remedy for such resulting delay, in accordance with and to the extent specifically provided above.

If the Contractor contends that it is entitled to a compensable time extension the Contractor shall within three days of the start of the action said to furnish justification for the compensable time extension, notify the Engineer in writing of the delay. Said notice shall specifically detail the nature and cause of the delay, the specific action of the County which renders this delay compensable, and shall include sufficient and credible documentation, to include but not limited to approved schedules, to allow the Engineer to evaluate the impact of the delay on the Contractor's critical path. Proper and timely notification to the Engineer of the delay, as provided above, is a condition precedent to any obligation on the part of the County TO GRANT A COMPENSABLE TIME EXTENSION, AND THE FAILURE OF THE Contractor to properly and timely render such notice shall serve as a bar on any litigation related to any claim for time or damages of any sort, including acceleration damages, arising out of the delay and serve as a waiver by the Contractor of any and all such claims.

The Contractor shall maintain for the duration of the alleged compensable delay, daily records. The maintenance of said records is a condition precedent to any obligation on the part of the County as to any compensable time extension. For each day for which said, confirmed, records are lacking, the County shall have no obligation as to extra time or compensation, and the lack of such records shall preclude the Contractor from maintaining any action for damages of any sort or extra time with respect to such delay.

In the event the County shall grant any time extension, the Contractor shall submit a revised schedule, compliant with the terms of the General Covenants and Conditions; said revised schedule will reflect all delays which previously impacted the work, including delays as may have been caused by the Contractor, and will reflect all time extensions granted to the date

## GENERAL COVENANTS AND CONDITIONS

of the revised schedule.

In the event that the Contractor is, per this Section, entitled to compensation for any delay, said compensation shall be liquidated and fixed at two hundred fifty dollars (\$250.00) per day of delay. The County and the Contractor agree that it is impossible, at the time this Contract is executed, to ascertain the precise amount of damages which the Contractor may suffer as a result of any compensable delay, and that proof of such damages will be difficult. Therefore, the County and the Contractor agree that the sum of two hundred fifty (\$250.00) dollars per day of delay is a fair and reasonable sum for all indirect costs as may be borne by the Contractor due to any compensable delay, including but not limited to, profits, interest, home office overhead, field office overhead, acceleration, loss of earnings, loss of productivity and/or efficiency, loss of bonding capacity, loss of opportunity, and all other indirect costs incurred by the Contractor or its subcontractors, materialmen, suppliers, or vendors.

Where a delay for which the Contractor would be entitled to compensation occurs concurrently with a delay for which the Contractor would not be entitled to any time extension, the Contractor shall be entitled to no compensation for the period of such concurrent delay.

The Contractor shall have no cause of action for the following items, and such items shall neither form the basis of any claim nor be included in compensation by the County, except insofar as the Contractor may be due liquidated damages for delay due to the Contractor pursuant to this Section, and this Section shall be the sole vehicle for recovery of the following items:

1. Home office expenses of any direct costs allocated from the headquarters of the Contractor
2. Loss of anticipated profits on this or any other project
3. Loss of bonding capacity
4. Losses due to projects not bid on
5. Loss of business opportunities
6. Loss of productivity on this or other project
7. Loss of interest on funds not paid
8. Costs to prepare, negotiate, or prosecute claims
9. Costs spent to achieve compliance with applicable laws and regulations
10. Increased bonding or insurance costs
11. Loss of efficiency
12. Acceleration costs
13. Loss of opportunity
14. All other indirect costs not listed herein.

### 15. SITE CONDITIONS

The County makes no representations or warranties as to site conditions, including but not limited to the nature or amount of any kind of soil material, the fitness of any material for use as fill, or the amount of water to be expected. Any information provided herein relating to site conditions is provided as advisory only, and is the County's best estimate of conditions at a particular location. Please note that underground conditions may vary from those observed by the County, and that the County cannot guarantee that the Contractor will encounter site conditions similar to those observed by the County.

## GENERAL COVENANTS AND CONDITIONS

The Contractor shall, prior to beginning construction activities, make whatever, site investigations the Contractor deems diligent or prudent, and shall take into account all site conditions which are known to the Contractor, or which could be known to the Contractor with reasonable, diligent, investigation, in planning or executing the work. Where site conditions delay the project, and said delay could have been avoided by reasonable investigations of the site by the Contractor, such delay will not be considered to be beyond the control of the Contractor, and no time extension shall be granted pursuant to Section 14 of the General Covenants and Conditions.

In the event that site conditions differ from those expected by the Contractor, the Contractor shall proceed to complete the work as contemplated by the Plans and Specifications at his own cost and expense. If in the discretion of the Engineer, the difference in site conditions renders completion of the work as described by the Plans and Specifications impossible, the Engineer may alter the work, in accordance with Section 3 of the General Covenants and Conditions, whereupon the Contractor shall be compensated for any extra work pursuant to Section 13 of the General Covenants and Conditions; the Engineer shall not alter the work where the site conditions render the work more difficult or costly to perform, if such work is otherwise still possible as described in the Contract Documents.

### 16. TERMINATION FOR CONVENIENCE AND CANCELED ITEMS

#### (1). Termination for Convenience

The Department reserves the right to, at its sole discretion, terminate this Contract without cause by giving a written Notice of Cancellation to the Contractor and its Surety at least ten (10) calendar days prior to the effective date of such cancellation.

In the event of termination by the Department, the Contractor will be paid for all labor performed, all materials and equipment furnished by the Contractor and its subcontractors, material men and suppliers and manufacturers of equipment less all authorized partial payments made prior to the date of cancellation. The Contractor will be paid for:

The value of all items of work completed under the Contract based upon the unit prices and/or the approved Schedule of Values (the Schedule of Values being the detailed cost breakdown satisfactory to the Engineer as specified in Section 9).

The actual cost, as verified by invoice, of acceptable materials and equipment delivered to the work site or irrevocably ordered prior to the date of receipt of the Notice of Cancellation. Said irrevocably ordered materials or equipment must be actually delivered to a Department storage yard designated by the Engineer prior to payment being authorized.

Items from the Schedule of Values or unit price items which are partially completed will be paid as specified in "Canceled Items" below.

In the event of termination or cancellation under this Section, the Contractor shall not be entitled to any anticipated profits for any work not performed due to such cancellation. No claims for loss of anticipated profits or for any other reason in connection with the cancellation of the Contract will be considered, nor shall the Contractor be entitled to any consequential damages.

## **GENERAL COVENANTS AND CONDITIONS**

### **(2). Canceled Items**

The Department shall have the right to cancel those portions of the Contract relating to the construction of any item provided for therein. Where that portion of the work contains completed payment items as called out in the Schedule of Values or unit price items which have been completed, they will be paid for as specified above in this section. Where items of work are not complete the Contractor will be allowed a profit percentage on the materials used and on construction work actually performed, at the same rates as provided for "Extra Work", but, as above, no allowance will be made for anticipated profits.

### **17. INSPECTING AND TESTING MATERIALS**

The inspection and testing of materials and finished articles to be incorporated in the work shall be made by bureaus, laboratories or agencies employed by the County, unless otherwise specifically provided for in the Specifications. The Contractor shall submit such samples, or such special or test pieces of materials as the Engineer may require. The cost of the materials or finished articles which may become damaged or destroyed in making the necessary tests to determine whether or not Specification requirements are met shall be borne by the Contractor. The Contractor shall not incorporate any material or finished article into the work until the results of the inspections or tests are known and he has been notified by the Engineer that the material or finished article is accepted. All materials must be of the specified quality and be equal to the approved sample, if a sample has been submitted. Materials or finished articles rejected by the Engineer shall be promptly removed from the site of the work.

### **18. CORRECTION OF WORK OR MATERIAL**

If at any time before the final acceptance of the Project, defects in the work or materials, unsatisfactory work or material, poor workmanship, damaged, destroyed, or incorrect work, are found by the Engineer, or any other Governmental Agency having jurisdiction over the work, the Contractor so notified shall immediately correct such work at his expense using whatever material and labor necessary in accordance with the Plans and Specifications.

Previous inspection of such work will not relieve the Contractor of his responsibility for any of the above deficiencies, although they may have been overlooked by the Engineer or may have been the results of damage from any cause. Neglect to make good for any of the above work shall result in the Engineer giving notice in writing to the Contractor specifying the conditions pertaining thereto and directing the Contractor to correct same. If the Contractor does not correct such conditions within five days after receipt of such notice, it shall be sufficient grounds for the Engineer to order the subject work discontinued and have the work completely remedied at the expense of the Contractor.

All materials are to be inspected before use and the Contractor shall notify the Engineer in time to enable him to inspect any inaccessible work or materials before being covered. The Contractor shall furnish at his expense necessary personnel and facilities for inspection of such work or materials after being covered, if so required. If in the Engineer's opinion the materials or finished items already installed, whether exposed or covered up, are damaged, destroyed or not in compliance with specifications, the Engineer shall notify the Contractor in writing, specifying the work or materials which shall not be incorporated in the Work without replacement or corrective work sufficient to obtain the Engineer's approval. All costs for the Correction of said work or materials shall be borne by the Contractor.

## **GENERAL COVENANTS AND CONDITIONS**

If in the opinion of the Engineer the structural, mechanical, or electrical integrity of installed work or materials on site is questionable, the Engineer may direct the Contractor to perform necessary tests to determine the acceptability of the item in question. The Contractor shall immediately employ a Professional Engineer licensed to practice in the State of Florida, to submit a testing procedure for approval as well as corrective methods of repair or replacement of the work if required. Engineering, testing and any required corrective work shall be performed immediately to minimize delays to the Project. If the tested work or materials are found to have deficiencies or not be in accordance with the best practices of the trade; even if the Department for its' convenience elects to accept the work or materials, all engineering, testing, and corrective costs shall be borne by the Contractor. Should the work or material in question be found to be without deficiencies and in accordance with the best practices of the trade, said costs will be borne by the Department to the extent of actual costs for said services. Any office overhead or other charges will remain with the Contractor. A non-compensable time extension will be granted if no corrective measures are required by the Engineer.

In all cases of corrective work including tests, prior to performing any work, the Contractor must submit his method of correction and obtain approval from the Engineer prior to correcting, removing, or replacing this work. The Engineer will only approve the completed work when it is satisfactorily performed. All costs for this work, including testing, shall be borne by the Contractor.

### **19. UNFINISHED OR INCOMPLETE WORK**

If at any time before final acceptance of the Project the Engineer finds there is unmanned or unfinished or incomplete work, or work delay or work stoppages, he shall notify the Contractor in writing to finish or complete the work at his expense forthwith using whatever labor, materials and equipment necessary to perform the work in accordance with the Plans and Specifications.

When the activity duration for any items shown on the construction schedule submitted beginning with the Notice to Proceed date exceed one hundred percent of the duration days indicated on the schedule, and the Contractor fails to make good for any of the above work as specified, the Engineer shall give notice to the Contractor in writing specifying the conditions pertaining thereto and directing the Contractor to perform the work. If the Contractor shall not begin to correct such conditions within five days of such notice, it shall be sufficient grounds for the Engineer to order the subject work discontinued and have the work completely remedied at the expense of the Contractor.

### **20. UNAVAILABILITY OF MATERIALS**

If the Contractor is unable to furnish or use any of the materials or equipment specified, because of any order by a governmental agency limiting the manufacture or use, or because of the supply situation in the general market for such material or equipment, the Contractor shall offer substitutes therefor. The substitutes shall be suitable for the purpose, considering the factors of quality, serviceability, appearance, and maintenance. No substitute shall be used until it has been approved by the Engineer.

No consideration will be given to the use of substitutes on account of market conditions unless the Contractor demonstrates that for the item in question, he placed his order and submitted shop drawings without delay, that he has shown due diligence in attempting to locate

## **GENERAL COVENANTS AND CONDITIONS**

the item as specified, and that the unavailability is due to market conditions in general throughout that particular industry.

If substitutes are used in the work, the compensation to be paid the Contractor will be subject to review and adjustment.

### **21. PROPERTY PROTECTION**

Buildings, sidewalks, fences, shade trees, lawns and all other improvements shall be duly protected by the Contractor. Property obstructions, such as sewers, drains, water or gas pipes, conduits, railroads, poles, walls, posts, bridges, etc., shall be carefully protected from damage and shall not be displaced if avoidable. Reasonable care shall be taken during construction to avoid damage to existing vegetation, ornamental shrubbery and trees. Damaged trees and shrubs are to be trimmed, treated or replaced, if necessary. Any damage created by the Contractor on private property, public right of way, or public property shall be replaced or repaired to a condition equal to or better than originally encountered, at his expense.

If the construction of the Project renders it necessary to move property, including privately owned public utility facilities located in public streets, highways or other public places, and all other types of property, the removal therefor shall be at the expense and risk of the Contractor. The Contractor is to obtain the consent of the owners or others in charge, and, before commencing, shall confer with them as to the best manner of protecting the interests involved.

Except as specifically provided in the Specifications, the Contractor shall not do any work that would affect any railway track, pipeline, telephone, telegraph, or electric transmission line, other structure, nor enter upon the right of way or other lands appurtenant thereto, until notified by the Engineer that the County has secured authority from the proper parties. The Contractor shall not be entitled to any extension of time or any extra compensation on account of any postponement, interference or delay except as provided in Section 14 herein.

The Department retains ownership of any materials encountered or being replaced under the Contract, and the Contractor, when so requested, shall carefully remove them and leave them neatly piled or stored at the site of the work for salvage by Department forces, except when otherwise provided by the Specifications.

### **22. USE OF EXPLOSIVES**

The use of explosives will not be permitted under this Contract.

### **23. SANITARY PROVISIONS**

The Contractor shall provide and maintain at his own expense, in a sanitary condition, such accommodations for the use of his employees as is necessary to comply with the requirements and regulations of the State of Florida Department of Health and Rehabilitative Services or Dade County Health Department. He shall commit no public nuisance. The Contractor shall furnish an adequate supply of drinking water for his employees.

### **24. CLEANING UP SITE OF WORK AND RESTORATION**

As soon as the work in any one locality is completed, the accumulated rubbish or surplus



## **GENERAL COVENANTS AND CONDITIONS**

materials thereat shall be promptly removed. The Contractor shall also restore all public and private property in a manner acceptable to the Engineer, to a condition equal to or better than pre-construction conditions. This shall apply to public and private property which has been displaced or damaged during the prosecution of the work, and the Contractor shall leave the site and vicinity unobstructed and in a neat and presentable condition.

In the event of delay exceeding two days after written notice is given to the Contractor by the Engineer to remove such rubbish or materials, or to restore displaced or damaged property, the Engineer may employ such labor and equipment as he may deem necessary for the purpose, and the cost of such work, together with the cost of supervision, shall be charged to the Contractor and shall be deducted from any money due him on the monthly or final estimate. No Contract shall be considered as having been completed until all rubbish and surplus materials have been removed and disposed of properly.

### **25. ASSIGNMENT OF CONTRACT**

No assignment of the Contract or of any part thereof, or of any moneys due or to become due thereunder, shall be made by the Contractor without the prior written approval of the County, which approval will be given only after the surety on both the Performance and Payment Bond has informed the County in writing that it has no objection to such assignment being made.

In the event that the Contractor undertakes to assign all or any part of any moneys due or to become due under the Contract, the instrument of assignment shall contain a provision substantially to the effect that it is agreed that the right of the assignee in and to any of such moneys shall be subject to the prior liens or claims of all persons for services rendered or materials supplied for the performance of all work embraced by the Contract.

### **26. TERMINATION OF CONTRACT BY DEPARTMENT**

A default in any contract with Miami-Dade County shall constitute a default in this Contract, and shall allow Miami-Dade County all remedies for default. In instances of contracts where there is a pool of pre-qualified bidders, a default shall result in the Contractor's removal from the pool.

If the Contractor fails to begin the work under the Contract within the time specified, or fails to perform the work with sufficient workmen and equipment or with sufficient materials to insure the prompt completion of the work, or performs the work unsatisfactorily, or neglects or refuses to remove materials or to perform anew such work as shall be rejected as defective and unsuitable, or shall discontinue the prosecution of the work, or shall become insolvent or be declared bankrupt, or shall commit any act of bankruptcy or insolvency, or shall make an assignment for the benefit of creditors, or from any other cause whatsoever shall not carry on the work in an acceptable manner, the Engineer may give notice in writing to the Contractor and to his surety of such delay, neglect or default, specifying the conditions pertaining thereto and directing the Contractor to correct same. If the Contractor shall not correct such conditions within a period of five days after receipt of such notice, the Director of the Miami-Dade Water and Sewer Department shall, upon written certificate from the Engineer reciting the facts of such delay, neglect or default and the failure of the Contractor to comply with the directions given in such notice, have full power and authority, without violating the Contract, to take the prosecution of the work out of the hands of the Contractor, to appropriate or use any or all materials or

## GENERAL COVENANTS AND CONDITIONS

equipment on the ground as may be suitable and acceptable, to enter into an agreement with another Contractor for the completion of the Project, or to use such other methods as, in the opinion of the Director of the Miami-Dade Water and Sewer Department, shall be required for the completion of the Project in an acceptable manner. All costs and charges incurred by the County, together with all costs of completing the work under Contract, shall be deducted from any moneys due or which may become due to the Contractor. In the event that the expense so incurred by the County shall be less than the sum which would have been payable under the Contract if the work had been completed by the Contractor, the Contractor shall be entitled to receive the difference; in case such expense shall exceed the sum which would have been payable under the Contract, the Contractor and the surety shall be liable and shall pay to the County the amount of such excess.

### 27. SCOPE OF PAYMENT

The Contractor shall receive and accept the compensation as herein provided in full payment for furnishing all materials, labor, tools and equipment, and for performing all work required to complete the Project under the Contract, and also in full payment for all loss or damage arising from the nature of the work or from the action of the elements, or from any unforeseen difficulties which may be encountered during the prosecution of the work until its final acceptance by the County.

Only net quantities of finished work will be measured and paid for. This shall apply to both unit price and aggregate sum items.

For each of the Items included and for which a unit price is stated in the Proposal, the total amount to be paid therefor by the County at such unit price shall be the measured amount of such Item incorporated in the completed Project by the Contractor and acceptable to the Engineer.

For each of the Items included and for which an aggregate sum price is stated in the Proposal, the aggregate amount to be paid therefor by the County for said Item will be made in accordance with the cost breakdown previously submitted to, and satisfactory to, the Engineer as required in Section 9 "Information and Drawings to be Furnished by the Contractor". Only those elements of the cost breakdown for the Item completed and incorporated in the completed Project by the Contractor and acceptable to the Engineer will be paid for. Canceled or incomplete elements of the cost breakdown of an aggregate sum item will be paid for as specified in Section 16 "Termination for Convenience and Canceled Items".

The unit and aggregate sum prices stated in the Proposal shall include all costs and expenses for mobilization, supervision, labor, fringe benefits including all insurances, union dues, pension plans, etc., equipment, materials, commissions, transportation charges and expenses, permit fees and licenses, patent fees and royalties, bond fees, removing crossing or other obstructions, protecting or maintaining pipes, drains, culverts, railroad tracks, buildings, bridges or other structures, furnishing temporary crossings or bridges, furnishing all stakes, batter boards and templates, common labor for staking out grades and lines and ordinary labor for handling materials during inspection, replacing any property disturbed, together with any and all other costs and expenses for performing and completing the work as specified, including full compensation for overhead, profit and home office expense. Failure by the Contractor to properly state a price shall not entitle the Contractor to later modify that price.

## GENERAL COVENANTS AND CONDITIONS

It is mutually agreed that, due to latent field conditions which cannot be foreseen at the time of advertising for bids, adjustment of Plans to such field conditions will be necessary during construction, and therefore such changes in the Plans shall be recognized as constituting a normal and expected margin of adjustment, not unusual and not involving nor permitting any change or modification of unit prices, provided only that resulting overruns or underruns from the quantities stated in the Proposal or cost breakdown of an aggregate sum item do not exceed a reasonable percentage. Changes involving any major item in an amount not more than fifty percent of the quantities listed in the Proposal or cost breakdown shall be construed as constituting such a reasonable percentage, in which case payment will be made for the revised quantities at the unit price bid in the Proposal or stated in the cost breakdown. A major item is construed to be any item of the Contract which amounts to at least five percent of the total Contract price. Changes involving any minor item in an increased amount not more than two hundred percent of the quantities listed in the Proposal or cost breakdown shall also be construed as constituting such a reasonable percentage, in which case payment will be made for the revised quantities at the unit price bid in the Proposal or stated in the cost breakdown. A minor item is construed to be any item of the Contract which amounts to less than five percent of the total Contract price. In the event that work exceeds the fifty percent of major items or 200 percent of minor items the Department may at their option pay for the additional labor, material, or equipment as extra work as outlined in Section 13, General Covenant and Conditions (a), (b), and (c).

Further, once any unit price item, either major or minor exceeds twenty (20) percent above the quantity stated in the Proposal, the Department will request that the Contractor negotiate a mutually agreeable decrease in the unit price for said item. If necessary, this may result in a negotiated stepped-price structure leading to lesser unit costs as quantities increase. If the Contractor refuses to negotiate or a mutually agreed settlement cannot be reached, the Department will perform any further immediately necessary work, or elective work to be performed for convenience (said work not being originally conceived as a part of the Project) by either:

1. Having the Contractor perform said work at the original prices up to the fifty and two hundred percent levels and thereafter, as extra work or:
2. Release said work for separate immediate quotation by other contractors or:
3. Perform said work with its own forces.

Whichever single or combination of methods is in the best interest of the County.

Once the Department has requested negotiations with the Contractor, any time loss while resolving the issue by one of the above specified methods will not be cause for an extension of Contract time, unless otherwise allowed

### 28. PARTIAL AND FINAL PAYMENT

The provisions of the Supplemental General Conditions when applicable and if in conflict with this section take precedent over the conditions of this section.

The Contractor will be paid each month ninety percent. See Specification Section 3.00.2 ("Time of Completion") of the invoiced cost including applicable sales taxes and shipping value of the work completed during the preceding month and ninety-five percent of the value of materials not already used, but which have been furnished by the Contractor under the Specifications, provided that such materials have been delivered, properly stored and inspected

## **GENERAL COVENANTS AND CONDITIONS**

by the Engineer and that payment therefor has been satisfactorily certified by the Contractor to the Engineer.

The Contractor may request, in writing, the value of labor, equipment and or materials, supplied by subcontractors, vendors or manufacturers to the Contractor, that the County pay this portion of his monthly progress payment as a joint check, payable to the Contractor and such Subcontractors, Vendors or manufacturers. Such request must be made monthly, and shall accompany the Contractor's monthly estimate for labor, equipment and/or materials furnished. Direct payment by the County, by joint check to the Contractor's Subcontractors or material and equipment Vendors or Suppliers or any other second party, must be agreeable to and so stated in writing by the Contractor's Surety.

For the purposes of processing contract pay estimates, the Contractor will be assigned a specific pay estimate period ending date by MDWASD which will apply to each calendar month throughout the course of the contract until the final pay estimate. The Contractor will be notified of their assigned pay estimate period ending date prior to the issuance of the Notice-To-Proceed.

Before the Contractor can receive any payment or draw hereunder, except the first partial payment, for moneys due him as a result of a percentage of the work completed, he must provide the Engineer with an affidavit and a release on the assigned pay estimate period ending date of each calendar month duly executed by each subcontractor and supplier of material or equipment for any work performed for the Project through the assigned pay estimate period ending date of the previous month. The affidavit and release shall state that all labor, material, equipment and supplies have been paid in full through the assigned pay estimate period ending date to the 25th day of the previous month. The affidavit and release shall also state that the subcontractor or supplier has been paid their full proportionate share of all draws including the last or previous draw for work performed or materials supplied for the Project through the assigned pay estimate period ending date of the previous month. In addition, the Contractor must provide the Engineer with a duly executed Certification of Contractor stating that all subcontractors and suppliers of material and equipment have been paid in full for work performed or materials supplied for the pay estimate period of the previous month. This does not apply to the first draw. The failure of the Contractor to provide the foregoing Certification of Contractor and an affidavit and release from each subcontractor and supplier shall result in the County withholding the current estimate until the Certification of Contractor and affidavit and release is provided or a Consent of Surety is provided to the Department in an approved form for the amount in dispute. If the Contractor fails to provide the required Certification of Contractor and affidavit and release(s) on the assigned pay estimate period ending date of the calendar month as specified after having been paid by the County by the 15th day of the following month, his next and subsequent dates of payment shall be revised to the 25th day of the month for all future estimates so that the presentation of the releases occur on the same date as the payment.

If applicable, the County will notify the Contractor and surety by certified letter informing them of the Contractor's non-compliance with the Contract Documents.

As a prerequisite for the acceptance of monthly payment applications the Contractor shall submit redlines, partially completed as-built plan sheets and fully complete as-built plan sheets, all as required by and satisfactory to, the Engineer. The Contractor shall prepare in accordance

## GENERAL COVENANTS AND CONDITIONS

with the terms of these Covenants and Conditions, and update through the pay estimate period ending date the current progress schedule and submit six complete print copies and two complete electronic copies to the Engineer for review and support for the requested progress payment. Such schedules shall show the progress of the work to date and schedule to completion of the project: in the event that the Contractor contends that completion will occur after the date specified in the Contract, the Contractor shall submit a schedule showing his expected completion date and also, if requested by the County, submit a schedule demonstrating how the work could be completed by the original contract completion date. In the event of submittal by the Contractor of a schedule showing completion occurring after the date specified in the Contract, the County may accept such schedule as fulfilling the requirement needed for monthly payment: however, such payment or acceptance shall not constitute adoption of such schedule or a modification of the Contract time, nor shall such payment or acceptance preclude the County from exercising any right granted it herein in the event that the Contractor does not finish the work within the Contract time.

For the purpose of preparing a monthly estimate, the Contractor jointly with the Inspector shall prepare the estimate and the Department will produce a computer print out to be signed by the Contractor. The Contractor shall provide the Inspector at the time of preparing the monthly estimate on the Department's form a list of subcontractors and vendors who have performed services or supplied materials or equipment during the period for which the estimate is being prepared. The Contractor and the Inspector shall, as a part of the preparation of the estimate, agree and sign off on the Contractor's list of required releases. The Engineer will evaluate the estimate of the value of all work done and materials furnished up through the pay estimate period ending date of each calendar month and will deduct therefrom ten percent, all liquidated damages assessed during that month in accordance with Section 11 herein, if any, and all previous payments and charges, and the balance will be paid by the County to the Contractor on or before the fifteenth day after the Contractor signs the pay estimate. The ten percent which is deducted each month is reserved by the County as partial guarantee to it of the faithful execution of the Contract by the Contractor.

When the computer printout of the estimate has been prepared, the Department will notify the Contractor that the estimate is ready for his signature. Signature of the Contractor on the computer printout of the estimate shall constitute acceptance by the Department of the Contractor's invoice for construction services performed. When the Contractor comes in to sign the estimate he must submit all required documentation, i.e., (1) two copies of the current updated Construction Progress Schedule, (2) Certified Payroll, reports for the Contractor and each Subcontractor that provided labor on the Project during that pay period (3) the Monthly Utilization and Monthly Employment Data Reports and (4) a Contractor's Invoice in the format provided by MDWASD and all required documentation. Additionally, the affidavit and all releases for the previous estimate shall be submitted in acceptable form. When a complete package of all required submittals has been turned in, the Contractor will be allowed to sign the estimate and the estimate will be processed for payment.

**The retainage shall be 10% for the contract. The 10% retainage will be reduced to 5% at the point where 50% of the value of the Contract is reached. At the 50% point by value, the Contractor may request half of the 10% retained up to that point.**

As a consideration for such payment, the County shall have the right to enter upon and put into proper service, any or all parts of the work which may be in condition for use. No claim or charge is to be made by the Contractor for such use, nor is such use to be construed as an acceptance by the County of any part of the work so used, however, the one year warranty

## **GENERAL COVENANTS AND CONDITIONS**

period shall commence from the date the individual equipment is put into full productive service and MDWASD determines that all of the work has been completed.

As soon as the Engineer is notified of the completion of the work and can assure himself by tests, inspection or otherwise, that all of the provisions of the Contract have been carried out to his satisfaction, he will make a final estimate of the value of all work done and will deduct therefrom all previous payments which have been made. The amount of the estimate, less any charges or damages herein provided for, and the reduction of any unused or unauthorized Contingency account funds remaining, will be paid.

When the computer printout of the final estimate has been prepared, the Department will notify the Contractor in writing that the final estimate is ready for his signature. Prior to being permitted to sign the final estimate, the Contractor must provide the Engineer with the Contractor's Invoice and all required documentation, i.e., (1) original and one copy of the Certified Payroll, and (2) original and one copy of the Monthly Utilization and Employment Date Reports, (3) Certificate of Contractor for the previous estimate and a Final Certificate of Contractor, and (4) Affidavit and Final Release from all subcontractors and suppliers. Once a complete package of duly executed documents has been submitted, and accepted by the MDWASD, the Contractor will be permitted to sign the final estimate. Should the Contractor fail to provide the Engineer with all of the required documentation cited above within thirty days from the date of written notification that the final estimate is ready for his signature, he may be held in default due to such delay. The County may withhold from payment under this contract any monies the County believes is owed it by the Contractor pursuant to any other contract or other claim.

### **Prompt Payment**

The successful Bidder's attention is directed to County Ordinance 94-40, providing for expedited payments to small businesses by County agencies and the Public Health Trust; creating dispute resolution procedures for payment of County and Public Health Trust obligations; and requiring the prime Contractor to issue prompt payments, and have the same dispute resolution procedures as the County, for all small business subcontractors. Failure of the prime vendor to issue prompt payment to small businesses, or to adhere to its dispute resolution procedures, may be cause for suspension, termination, and debarment, in accordance with the terms of the County contract or Public Health Trust contract and debarment procedures of the County.

### **Existing Debts to County**

In accordance with Miami-Dade County Implementing Order 3-9, Accounts Receivable Adjustments, if money is owed by the Contractor to the County, whether under this Contract or for any other purpose, the County reserves the right to retain such amount from payment due by County to the Contractor under this Contract. Such retained amount shall be applied to the amount owed by the Contractor to the County. The Contractor shall have no further claim to such retained amounts which shall be deemed full accord and satisfaction of the amount due by the County to the Contractor for the applicable payment due herein.

### **29. NOTICE AND SERVICE THEREOF**

All notices, demands, requests, instructions, approvals and claims shall be in writing. Any notice to or demand upon the Contractor shall be sufficiently given if delivered to the office of

## **GENERAL COVENANTS AND CONDITIONS**

the Contractor specified in the Proposal (or to such other office as the Contractor may from time to time designate to the Engineer in writing), or if deposited in the United States mail in a sealed, postage-prepaid envelope, or if delivered, with charges prepaid, to any telegraph company for transmission, in each case addressed to such office.

All notices or other papers required to be delivered by the Contractor to the County or to any of its representatives shall, unless otherwise specified in writing to the Contractor, be delivered in the office of the Director, Miami-Dade Water and Sewer Department, Douglas Road Office Building, 3071 S.W. 38th Avenue, Miami, Florida, and any notice to or demand upon the County shall be sufficiently given if delivered to the office of said Director, or if deposited in the United States mail in a sealed, postage-prepaid envelope, or delivered with charges prepaid to any telegraph company for transmission, in each case addressed to said Director.

Any such notice or demand shall be deemed to have been given or made as of the time of actual delivery, or in the case of mailing, when the same should have been received in due course of post, or in the case of telegrams, at the time of actual receipt thereof.

### **30. SAFETY STANDARDS**

The Contractor shall comply in every respect with all Federal, State and local safety and health regulations. Copies of the Federal Regulations may be obtained from the U.S. Department of Labor, Occupational Safety and Health Administration, 299 E. Broward Boulevard, Room 302, Fort Lauderdale, Florida 33301.

When the Contract involves work on a plant, pump station or other process site the Contractor shall comply with the Department's Process Safety Management Plan and instruct his personnel as required by that plan.

### **31. LABOR STANDARDS**

Section 446.101, Florida Statutes, as amended, which is hereby by reference incorporated herein, provided labor standards for ratios of apprentices or trainees to journeymen on State, County or municipal contracts. It shall be the responsibility of the Contractor, prior to the opening of bids, to inform himself of the provisions of Section 446.101, Florida Statutes, as amended, which are, or may become, applicable to the Contract, and he shall abide by these provisions at no cost to the County. The Contractor is advised to direct all inquiries concerning Section 446.101, Florida Statutes, as amended.

### **32. COUNTY NOT LIABLE FOR LATE DELIVERY OF MATERIALS**

If it is specifically stated in the Specifications that the Department will furnish materials or equipment to the Contractor for incorporation into the work for which this Contract pertains, the County shall not be liable for any expenses, losses, damages, claims or demands including but not limited to, all direct costs of Contractor such as labor, material, job overhead, and profit markup but also includes any costs for modifications or changes in sequence of work to be performed, delays, rescheduling, disruptions, extended direct overhead or general overhead, acceleration, material or other escalation which includes wages, and other impact cost, or inflationary factors, arising out of any late delivery of such materials or equipment caused by any force Majeure. Compliance with delivery schedules by the Department shall be excused when delays are caused by force Majeure, and, if the delay causes the Contractor to exceed the

## GENERAL COVENANTS AND CONDITIONS

Contract time stipulated for the final completion of the Project, a non-compensable time extension in the Contract time. An extension in this Contract time will be allowed equal to the length of the delay.

The term "force Majeure" as used herein shall mean Acts of God, strikes, lockouts, any late delivery of the Owner's supplied material and equipment due to transportation delays beyond Department's control, or other industrial disturbances; acts of public enemy, blockades, wars, insurrections, or riots; epidemics, landslides, earthquakes, fire, storms, floods, or washouts; arrests, title disputes, or other litigation; governmental restraints, either Federal or County, civil or military; civil disturbances; explosions; inability to obtain necessary materials or equipment, supplies, labor, or permits whether due to existing or future rules, regulations, orders, laws, or proclamations, either Federal, State or County, civil or military, or otherwise; and other causes beyond the control of the Department or County, whether or not specifically enumerated herein.

### 33. ALLOWANCE ACCOUNT ITEMS IN THE PROPOSAL

Allowance account Items in the amounts indicated on the Proposal and as described in these Documents have been established for certain types of work. The Contractor shall perform such work only upon receipt of written Work Orders from the Engineer.

All provisions of Section 13 of the General Covenants and Conditions for Extra Work will prevail, but if the Work Order(s) requires that all or any part of the work be done on a Lump Sum Basis, and unless the Engineer directs otherwise, the Contractor shall solicit not less than three subcontracts or materials bids on work normally done by specialty subcontractors and/or materials vendors. Work shall proceed only upon written approval by the Engineer of the Lump Sum amount agreed upon with the Contractor.

All work shall be done in accordance with all the provisions and requirements of Section 13 Extra Work and Payment Therefore, of the General Conditions that shall govern the conduct and payment for this work.

Should the aggregate of charges for all approved Work Orders under the Allowance Account be less than the amount of the Allowance Account Item, the final Contract price will be decreased by the amount of the difference. No work shall be performed that would cause total charges under an Allowance Account Item to exceed the authorized amount.

### 34. FAMILY LEAVE POLICY

The award of this Contract is conditioned on compliance with Ordinance 142-91 of the code of Miami-Dade County, Florida, effective March 15, 1992, Resolution 1499-91 as amended by Resolution 183-00 for Contracts that exceed ten thousand dollars (\$10,000).

All bidders with at least fifty employees for each working day during each of twenty or more work weeks in the current or preceding calendar years submitting proposals in conjunction with this solicitation are hereby advised that award of this Contract is conditioned on certification that their firm has a family leave policy in conformance with the following:

Such policies must provide the employee with the following provisions:



## **GENERAL COVENANTS AND CONDITIONS**

An employee who has worked for the same employer for at least one year shall be entitled to ninety days of family leave during any twenty four month period, for the birth or adoption of a child, or for the care of a child, spouse or other close relative who has a serious health condition.

A Family Leave Policy must entitle employees to take leave without risk of termination of employment or retaliation by employers.

The obligation to provide family leave to their employees shall be a contractual obligation. Resolution 183-00 provides that failure to comply with these requirements may result in debarment.

### **35. DRUG FREE WORKPLACE REQUIREMENT**

The award of this Contract must comply with Ordinance 92-15 amending Section 2-8.1 of the code of Metropolitan Dade County, Florida effective, March 17, 1992, as amended by Ordinance 00-30, which requires bidders to have a drug free workplace when a Contract exceeds ten thousand dollars (\$10,000).

All bidders submitting proposals in conjunction with this solicitation are advised that award of this Contract is conditioned on the firm advising each employee in writing of the following:

1. Dangers of drug abuse in the workplace.
2. The firm's policy of maintaining a drug-free environment at all workplaces.
3. Availability of drug counseling, rehabilitation and employee assistance programs.
4. Penalties that may be imposed upon employees for drug abuse violations.

The firm shall also require an employee to sign a statement, as a condition of employment, that the employee will abide by the terms and notify the employer of any criminal drug conviction occurring no later than five days after receiving notice of such conviction and impose appropriate personnel action against the employee up to and including termination.

Any contract or transaction in violation of this Ordinance is voidable, and any person who willfully or knowingly supplies false information can be punished by a fine of up to five hundred dollars (\$500.00) or may be considered to be in default of this Contract, or both and under the provisions of Ordinance 00-30, may be debarred.

### **36. BIDDER DISCLOSURE REQUIREMENT**

The award of this Contract must comply with Ordinance 90-133 amending Section 2-8.1 of the Code of Metropolitan Dade County, Florida, effective December 14, 1990, which requires to disclose additional information when a Contract exceeds ten thousand dollars (\$10,000).

Except for publicly traded corporations and governmental agencies, all bidders submitting proposals in conjunction with this solicitation are advised that award of this Contract will be contingent upon receipt of the following disclosure information:

## GENERAL COVENANTS AND CONDITIONS

- A. whether the entity has a collective bargaining agreement with its employees,
- B. the schedule of wage rates (including overtime) and benefits to be paid employees performing work under such contract or transaction,
- C. the health care benefits to be paid to employees performing work under such contract or transaction
- D. and a current breakdown of the entity's work force as to race, national origin and gender.

The successful low bid Bidder will be required to submit this information within fifteen calendar days following written notification of intent to award. Failure to submit this sworn statement within the specified time frame will result in the proposal being rejected and award made to the next low bidder.

It should be noted that any Contract or transaction in violation of this Ordinance is voidable, and any person who willfully fails to disclose the required information or knowingly discloses false information can be punished by a fine of up to five hundred dollars (\$500.00) or by imprisonment in the County jail for up to sixty days, or both.

### 37. BIDDER'S AFFIDAVIT

The Contractor shall be subject to and comply with all provisions of Ordinance No.93-129. A breach of the clauses contained in the Contract adversely affecting the performance of the Contractor on this Project may be grounds for the initiation of debarment procedures.

### 38. QUARTERLY REPORTS

The successful Bidder's attention is directed to County Resolution No. 113-94 and Resolution No. 1634-93. Pursuant to the Resolutions, the Contractor is required to file with the Miami-Dade Water and Sewer Department, Douglas Road Office Building, 3071 S.W. 38th Avenue, Miami, Florida 33146, to the Compliance Section, quarterly reports due on or before the "**last day**" of the months of April, July, October and January, reporting the amount of Contract monies received from the County on this and all other County Projects and monies received on private sector work.

The Form of Quarterly Report to be submitted, is appended hereto.

### 39. INDEPENDENT PRIVATE-SECTOR INSPECTOR GENERAL

The County shall have the right but not the obligation to retain the services of an independent private-sector inspector general (IPSIG) who may be engaged to audit, investigate, monitor, oversee, inspect and review the operations, activities and performance of the Contractor and County in connection with this Contract. The scope of services performed by an IPSIG may include, but are not limited to, monitoring and investigating compliance with Contract Specifications; project costs; and investigating and preventing corruption and fraud.

The IPSIG may perform its services at all levels of the contracting and procurement process including but not limited to project design, establishment of bid specifications, bid

## GENERAL COVENANTS AND CONDITIONS

submittals, activities of Contractor, its officers, agents and employees, lobbyists, county staff and elected officials.

Upon (10) ten days written notice to Contractor from an IPSIG, the Contractor shall make all requested records and documents available to the IPSIG for inspection and copying. The IPSIG shall have the right to examine all documents and records in the Contractor's possession, custody or control which in the IPSIG's sole judgment pertain to performance of the Contract, including but not limited to original estimate files, bid and change order estimates, worksheets, proposals and agreements from and with successful and unsuccessful subcontractors and suppliers, all project-related correspondence, memoranda, instructions, financial documents, construction documents, bid and Contract documents, back-charge document, all documents and records which involve cash, trade or volume discounts, insurance proceeds, rebates, or dividends received, payroll and personnel records, and supporting documentation for the aforesaid documents and records.

The provisions in this section shall apply to the Contractor, its officers, agents and employees. The Contractor shall incorporate the provisions in this section in all subcontracts and all other agreements executed by Contractor in connection with the performance of the Contract.

Nothing in this Contract shall impair any independent right of the County to conduct audit or investigate activities. The provisions of this section are not intended nor shall they be construed to impose any liability on the County by Contractor or third parties.

### 40. OFFICE OF THE MIAMI-DADE COUNTY INSPECTOR GENERAL

The attention of the successful respondent (Contractor or Consultant ) to this Solicitation, herein referred to as the Contractor, is hereby directed to the requirements of MDC Code Section 2-1076; in that the Office of the **MIAMI-DADE COUNTY INSPECTOR GENERAL (IG)** shall have the authority and power to review past, present and proposed County programs, accounts, records, contracts and transactions. The IG shall have the power to subpoena witnesses, administer oaths and require the production of records. Upon ten (10) days written notice to the Contractor from IG, the Contractor shall make all requested records and documents available to the IG for inspection and copying.

The IG shall have the power to report and/or recommend to the Board of County Commissioners whether a particular project, program, contract or transaction is or was necessary and, if deemed necessary, whether the method used for implementing the project or program is or was efficient both financially and operationally. Monitoring of an existing project or program may include reporting whether the project is on time, within budget and in conformity with plans, specifications, and applicable law. The IG shall have the power to analyze the need for, and reasonableness of, proposed change orders.

The IG may, on a random basis, perform audits on all County contracts throughout the duration of said Contract (hereinafter "random audits"). This random audit is separate and distinct from any other audit by the County. **To pay for the functions of the Office of the Inspector General, any and all payments to be made to the Contractor under this Contract will be assessed one quarter of one percent of the total amount of the payment, to be deducted from each progress payment as the same becomes due** unless, as stated elsewhere in the Contract Documents, this Contract is federally or state funded where federal or

## GENERAL COVENANTS AND CONDITIONS

state law or regulations preclude such a charge. **The Contractor shall in stating its agreed prices be mindful of this assessment, which will not be separately identified, calculated or adjusted in the proposal or bid form.**

The IG shall have the power to retain and coordinate the services of an independent private sector inspector general (**IPSIG**) who may be engaged to perform said random audits, as well as audit, investigate, monitor, oversee, inspect, and review the operations, activities and performance and procurement process including, but not limited to, project design, establishment of bid specifications, bid submittals, activities of the Contractor, its officers, agents and employees, lobbyists, County staff and elected officials in order to ensure compliance with contract specifications and detect corruption and fraud.

The IG is authorized to investigate any alleged violation by a contractor of its Code of Business Ethics, pursuant of MDC Code Section 2-8.1.

The provisions in this section shall apply to the Contractor, its officers, agents and employees. The Contractor shall incorporate the provisions in this section in all subcontracts and all other agreements executed by the Contractor in connection with the performance of this Contract.

Nothing in this Contract shall impair any independent right of the County to conduct audit or investigative activities. The provisions of the section are neither intended nor shall they be construed to impose any liability on the County by the Contractor or third parties.

### 41. AUDIT RIGHTS AND REVIEW OF RECORDS

The Contractor shall, during the term of this Contract and for a period of five years thereafter, allow the County and its duly authorized representatives to inspect all payroll records, invoices for materials, books of account, project correspondences, and project related files and all relevant records pertinent to the Contract. The County retains the right to audit accounts and to access all files, correspondences and documents in reference to all work performed under this Contract. The County and its authorized representatives shall be provided full access upon request to all documents, including those in the possession of subcontractors or consultants or suppliers during the work and for a period of five years thereafter. In the case of any litigation regarding the work or the Contract, such audit rights shall extend until final settlement of all claims at issue in such litigation. Failure to allow the County or its representatives access shall be deemed a waiver of the Contractor's claims.

### 42. SUBSTANTIAL COMPLETION AND PUNCH LIST

Upon attainment of Substantial Completion as defined in the Instruction to Bidders, the Contractor shall submit, in writing, a request for substantial completion verification from the Engineer. If the Engineer verifies Substantial Completion for the Project, the Contractor and Construction Manager shall schedule a meeting in which they will, together, identify all outstanding items required to complete the Project in its entirety. Should a good-faith dispute exist concerning the inclusion or extent of an item required by the MD-WASD, the Contractor shall immediately proceed to perform the work of the item as instructed, but the procedures specified for disputed items in Section 4 "Authority of the Engineer" shall apply.

The items identified to be completed shall constitute the Punch List. The Construction

## GENERAL COVENANTS AND CONDITIONS

Manager and the Contractor shall have seven calendar days from the date of substantial completion to create the Punch List. When the Contractor successfully completes all identified items to the satisfaction of the Engineer in accordance with the Contract Documents, the Contractor may submit a payment request for all remaining retainage withheld for the Project.

Should the Contractor not successfully complete any items contained in the Punch List or if a good-faith dispute exists as to whether one or more items identified on the list have been completed pursuant to the Contract, the Construction Manager may elect to continue to withhold an amount not to exceed 150 percent of the total costs to complete such items and release the remaining retainage.

### 43. STANDARD WORK HOURS AND CONSTRUCTION MANAGEMENT OVERTIME

#### Standard Work Hours

Standard Work Hours shall allow for up to a 10 hour work day starting at 7AM or as otherwise approved, Monday thru Friday. The Contractor shall coordinate his daily schedule with the Construction Manager at the Pre-Construction Meeting to have inspectors at the project site during the work. The standard work day shall be up to 10 hours of work with 1 hour for lunch. Modifications to the standard construction schedule shall be coordinated with the Construction Manager at least one week in advance. Optional work beyond the standard 10 hour work day or work on Saturdays, Sundays or Holidays shall be done with the approval of the Construction Manager and with a preapproved overtime compensation of the WASD Inspector charged to the Contractor. Set-up and demobilization work that do not require inspection may be performed outside of the standard 10 hour work day.

#### WASD Inspections Outside Of Normal Work Hours

In the event that the Contractor elects to work beyond the standard 10-hour work day to include Saturdays, Sundays or Holidays, the Contractor shall be responsible for WASD inspector overtime cost. The Cost of the WASD Inspector shall be \$90.00 per hour. The Contractor shall be billed for the overtime cost. Any WASD Inspection Cost outstanding at the completion of the project shall be deducted from the final retainage.

Work outside of the Standard Work Hours that are required for one of the reasons provided below do not require reimbursement of WASD inspector overtime cost.

1. Night work, special working hours or other off-peak hour work required due to permit conditions.
2. Special working hours required for WASD operational needs (work required at low flow times, connections to existing mains at low flow times, shutdowns, etc.).
3. Cleaning and testing work required to be done at night.
4. Roadway Work that is required during off-peak hours due to traffic control requirements.
5. Microtunnel or directional drill operations.
6. Emergency projects.
7. Work on homeowner services.
8. Additional work ordered by the Engineer.
9. Work within a school zone.

## GENERAL COVENANTS AND CONDITIONS

10. Any other special condition approved by the Engineer.

The Contractor shall include in his bid price any WASD inspector overtime cost that he will required to facilitate his construction work. Acceleration of work ordered by the Department or needed by the Contractor due to his delay or his inability to complete the work within the required Construction Time shall not be justification to waive the WASD inspector overtime cost. Coordinate with the Construction Manager to schedule any WASD inspectors for overtime at least one week in advance.

### 44. ASBESTOS

#### Remediation Work

The abatement of asbestos containing material shall be performed by a Florida Licensed Asbestos Contractor. The asbestos abatement contractor provide proof of license, employee worker certificates (medical, fit-test, training), site work action plan, company safety and respiratory protection plan, and an approved copy of the EPA- NESHAP Demolition and Renovation Notification Form prior to the Notice To Proceed.

#### Prohibition on Asbestos Containing Materials

The Department will not accept any materials that contain asbestos. It shall be the Contractor's responsibility to verify that materials furnished to the Department contain no asbestos minerals. Any materials found to have asbestos and installed by the Contractor shall be removed at his expense. Some construction materials that may be currently sold on the market by various manufacturer's contain asbestos materials are drywall/joint compound, plaster, texture coats, vinyl floor tiles, adhesives, roofing tars, felt, shingles, acoustic ceilings, fireproofing, caulk, specialty gaskets, fire doors, insulation, particle filters, HVAC ducts, drilling fluid additives, and insulation boards.

The Contractor is hereby alerted to the fact that some of these above listed materials manufactured abroad may contain asbestos containing minerals from the serpentine or amphibole group. The asbestos containing minerals to be avoided are as follows:

Asbestos Type	CAS #	Formula
Chrysotile	12001-29-5	$Mg_3(Si_2O_5)(OH)_4$
Amosite	12172-73-5	$Fe_7Si_8O_{22}(OH)_2$
Crocidolite	12001-28-4	$Na_2Fe^{2+}3Fe^{3+}2Si_8O_{22}(OH)_2$
Tremolite	77536-68-6	$Ca_2Mg_5Si_8O_{22}(OH)_2$
Actinolite	77536-66-4	$Ca_2(Mg,Fe)_5(Si_8O_{22})(OH)_2$
Anthophyllite	77536-67-5	$(Mg, Fe)_7Si_8O_{22}(OH)_2$
Richterite	17068-76-7	$Na(Ca,Na)(Mg, Fe^{++})_5(Si_8O_{22})(OH)_2$
Winchite		$(Ca,Na)Mg_4(Al,Fe^{3+})(Si_8O_{22})(OH)_2$

The Contractor shall check the label of every product submitted. Shop drawing approval shall not absolve the Contractor of the responsibility of submitting asbestos free materials.

## **GENERAL COVENANTS AND CONDITIONS**

### **45. PUBLIC RECORDS AND CONTRACTS FOR SERVICES PERFORMED ON BEHALF OF MIAMI-DADE COUNTY**

The Contractor shall comply with the Public Records Laws of the State of Florida, including but not limited to: (1) keeping and maintaining all public records that ordinarily and necessarily would be required by Miami-Dade County (County) in order to perform the service; (2) providing the public with access to public records on the same terms and conditions that the County would provide the records and at a cost that does not exceed the cost provided in Chapter 119, Florida Statutes, or as otherwise provided by law; (3) ensuring that public records that are exempt or confidential and exempt from public records disclosure requirements are not disclosed except as authorized by law; and (4) meeting all requirements for retaining public records and transferring, at no cost, to the County all public records in possession of the Contractor upon termination of the contract and destroying any duplicate public records that are exempt or confidential and exempt from public records disclosure requirements upon such transfer. In addition, all records stored electronically must be provided to the County in a format that is compatible with the information technology systems of the County. Failure to meet any of these provisions or to comply with Florida's Public Records Laws as applicable shall be a material breach of the agreement and shall be enforced in accordance with the terms of the agreement.

**IF THE CONTRACTOR HAS QUESTIONS REGARDING THE APPLICATION OF CHAPTER 119, FLORIDA STATUTES, TO THE CONTRACTOR'S DUTY TO PROVIDE PUBLIC RECORDS RELATING TO THIS CONTRACT, CONTACT THE CUSTODIAN OF PUBLIC RECORDS AT:**

**(305) 375-5773**

**ISD-VSS@MIAMIDADE.GOV**

**111 NW 1 STREET, SUITE 1300, MIAMI, FLORIDA 33128**

A Contractor who fails to provide the public records within a reasonable time may be subject to penalties under Chapter 119.10, Florida Statutes.

### **46. ASPIRATIONAL POLICY REGARDING DIVERSITY**

Pursuant to Resolution No. R-1106-15 Miami-Dade County vendors are encouraged to utilize a diverse workforce that is reflective of the racial, gender and ethnic diversity of Miami-Dade County and employ locally-based small firms and employees from the communities where work is being performed in their performance of work for the County. This policy shall not be a condition of contracting with the County, nor will it be a factor in the evaluation of solicitations unless permitted by law.