

ABBREVIATIONS

- A/C Length
- A/C Air Conditioner Pad
- ASPH. Asphalt
- B.S. Block Structure
- C.B.S. Concrete Block Structure
- C.C. Curb & Gutter
- C/L Center Line
- C/S Concrete Slab
- D.C. Depressed Curb
- D.W. Driveway
- E.T.P. Electric Transformer Pad
- E.T. Electric Transformer
- F.L.P. Found on Plot
- F.N.D. Found Nail & Disc
- F.R. Found Rebar
- I.D. Identification
- L.F.E. Lowest Floor Elevation
- M. Monument
- M/L Monument Line
- P.B. Permanent Control Point
- P.C.P. Permanent Control Point
- P.L. Planter
- P/L Property Line
- P.R.M. Permanent Reference Monument
- R/L Right-of-Way Line
- S.M. Survey Monument
- T.B.M. Temporary Benchmark
- V.G. Valley Gutter
- V.G. Chain Link Fence
- CL.F. Chain Link Fence

LEGEND

- CLP Concrete Light Pole
- MLP Metal Light Pole
- GW Guy Wire
- UP Utility Power Pole
- FM Fire Hydrant
- WM Water Meter
- EM Electric Meter
- EB Electric Box
- SB Sewer Manhole
- OU Overhead Utility Lines
- LP Light Pole
- GV Gas Valve
- WV Water Valve
- WM Water Manhole
- TKM Telephone Manhole
- MW Monitoring Well
- PM Pumping Meter
- CLF Chain Link Fence
- UM Unknown Manhole
- SV Sewer Valve
- MB Mail Box
- SE Spot Elevation
- TR Temporary Benchmark
- DS Dimeter-Height-Spread
- 1.5'-15'-10' Right-of-Way Lines
- PC Property Corner
- TS Traffic Sign
- CB Catch Basin
- DM Drainage Manhole
- WF Wood Fence
- IF Iron Fence
- CB.S. Wall
- CO Clean Out
- GP Guard Pole
- BNN Back Flow Preventer
- IC Irrigation Control Valve
- PH Telephone Booth
- FM Force Main Valve

TREE LEGEND

- COMMON NAME
- Tree (Species unknown)
- Palm Tree
- Black Olive
- Oak Tree
- Monogony
- Coccoloba Palm
- Ficus Tree
- Anchor Vine
- Royal Palmetto
- Arco
- Casahuate
- Fern Tree
- Screw pine
- Silver Trumpet
- Star Jasmine
- Malibuca
- Hong Kong Orchid Tree
- Norfolk Island Pine
- Decoeno
- Battledor Tree
- Schefflera
- Hibiscus Tree

* Tree types are determined to the best of our ability.

TOPOGRAPHIC SURVEY

of
 PORTION OF S.W. 9th STREET, S.W. 10th STREET, S.W. 11th STREET AND
 S.W. 12th STREET BETWEEN
 S.W. 1st AVENUE AND S.E. 1st AVENUE, MIAMI,
 SECTION 12, TOWNSHIP 54 SOUTH, RANGE 41 EAST
 MIAMI - DADE COUNTY, FLORIDA
 for
 TY LIN INTERNATIONAL

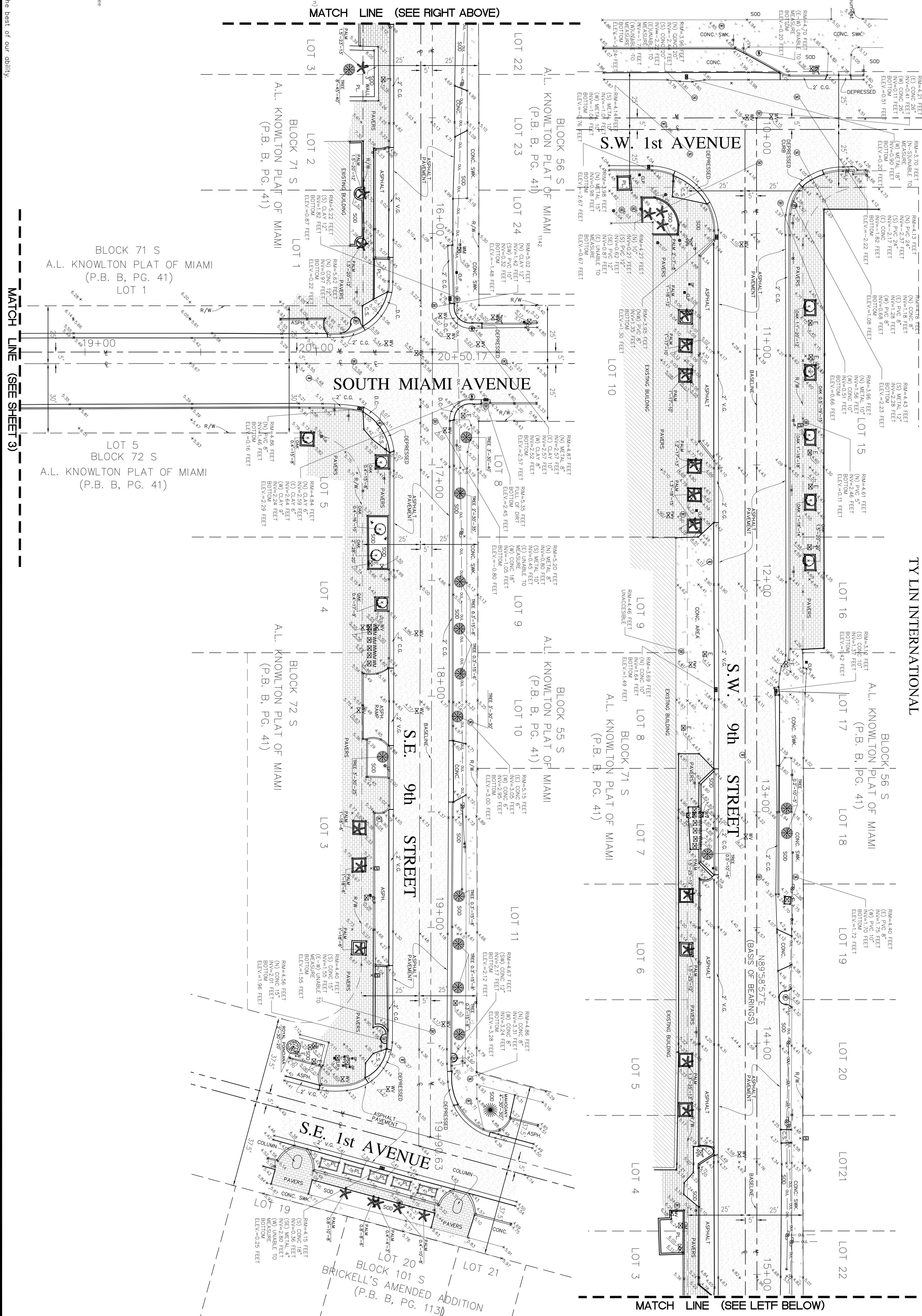
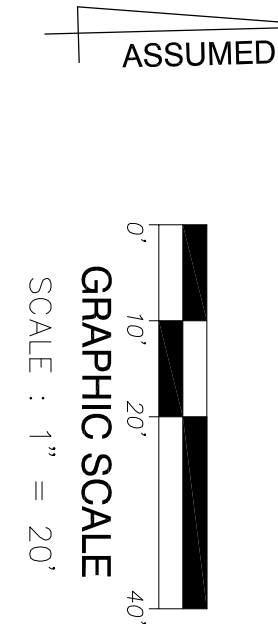

REVISIONS	BY

TOPOGRAPHIC SURVEY
 of
 PORTION OF S.W. 9th STREET, S.W. 10th STREET, S.W. 11th STREET
 AND S.W. 12th STREET BETWEEN S.W. 1st AVE. AND S.E. 1st AVE.,
 MIAMI, SECTION 12, TOWNSHIP 54 SOUTH, RANGE 41 EAST
 MIAMI - DADE COUNTY, FLORIDA
 for
 TY LIN INTERNATIONAL

J. Bonfill & Associates, Inc.
 ARCHITECTS, LAND SURVEYORS & MAPPERS
 Florida Certificate of Authorization LB3398
 9360 S.W. 72nd Street Suite 265
 Miami, Florida 33173 (305) 598-8383

Project: 10-0240
 Job: 10-0240
 Date: 08-24-2010
 Drawn: G.P., J.S.
 Checked: J.B.
 Scale: AS SHOWN
 Field Book: ON FILE
 SHEET 2 OF 9

ABBREVIATIONS

- A/C Length
- A/C Air Conditioner Pad
- A.S.P.H. Asphalt
- B.S. Block Structure
- C.B.S. Concrete Block Structure
- C.G. Curb & Gutter
- C.L. Center Line
- C.S. Concrete Slab
- D.C. Depressed Curb
- D.W. Driveway
- E.T.P. Electric Transformer Pad
- F.I.P. Found Iron Pipe
- F.N.D. Found Nail & Disc
- F.R. Found Rebar
- I.D. Identification
- L.F.E. Lowest Floor Elevation
- M/W. Monument Line
- P.B. Plat Book
- P.C.P. Permanent Control Point
- P.L. Pin
- P/L Property Line
- P.R.M. Permanent Reference Monument
- R.F.M. Right-of-Way Line
- S.M. Survey Monument
- T.B.M. Temporary Benchmark
- V.G. Valley Gutter
- V.G. Chain Link Fence

LEGEND

- CLP Concrete Light Pole
- MLP Metal Light Pole
- GW Guy Wire
- UP Utility Power Pole
- WH Water Hydrant
- WM Water Meter
- EB Electric Box
- TB Telephone Box
- SM Sewer Manhole
- OU Overhead Utility Lines
- LP Light Pole
- GV Gas Valve
- WV Water Valve
- WM Water Manhole
- TM Telephone Manhole
- MW Monitoring Well
- PM Parking Meter
- CLF Chain Link Fence
- UM Unknown Manhole
- SV Sewer Valve
- MB Mail Box
- SE Spot Elevation
- TR Temporary Benchmark
- 1.5'-15'-10" Diameter--Height--Spread Right-of-Way Lines
- PC Property Corner
- TS Traffic Sign
- CB Catch Basin
- DM Drainage Manhole
- WF Wood Fence
- IF Iron Fence
- CB.S. Wall
- CO Clean Out
- GP Guard Pole
- B.F.N. Back Flow Preventer
- PH Irrigation Control Valve
- PH Telephone Booth
- FM Force Main Valve

TREE LEGEND

- COMMON NAME
- SYMBOL
- Tree (Species unknown)
- Palm Tree
- Black Olive
- Oak Tree
- Mangrove
- Coconut Palm
- Ficus Tree
- Acacia
- Royal Palmetto
- Arcaea
- Cassia
- Fern Tree
- Screw pine
- Silver Trumpet
- Star Jasmine
- Melaleuca
- Hong Kong Orchid Tree
- Norfolk Island Pine
- Discoeno
- Bottlebrush Tree
- Scheffera
- Hibiscus Tree

* Tree types are determined to the best of our ability.

TOPOGRAPHIC SURVEY

of
PORTION OF S.W. 9th STREET, S.W. 10th STREET, S.W. 11th STREET AND S.W. 12th STREET BETWEEN S.W. 1st AVENUE AND S.E. 1st AVENUE, MIAMI, SECTION 12, TOWNSHIP 54 SOUTH, RANGE 41 EAST MIAMI - DADE COUNTY, FLORIDA
 for
TY LIN INTERNATIONAL

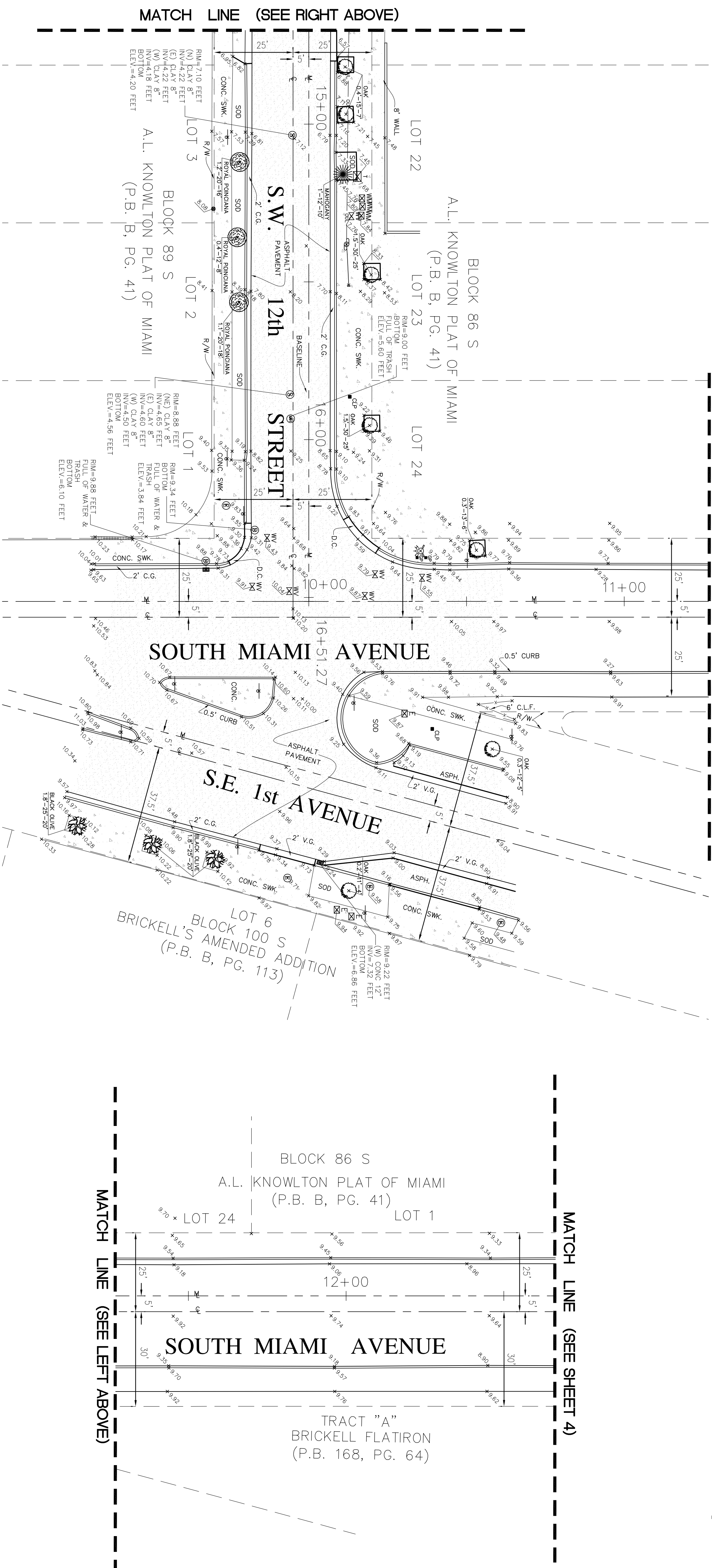
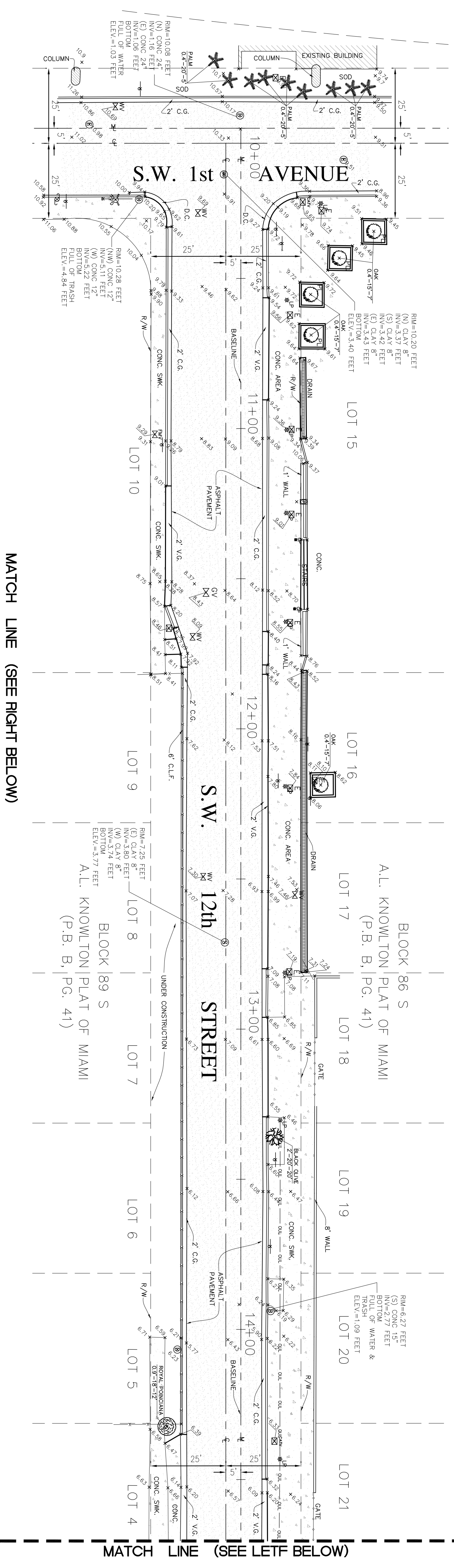
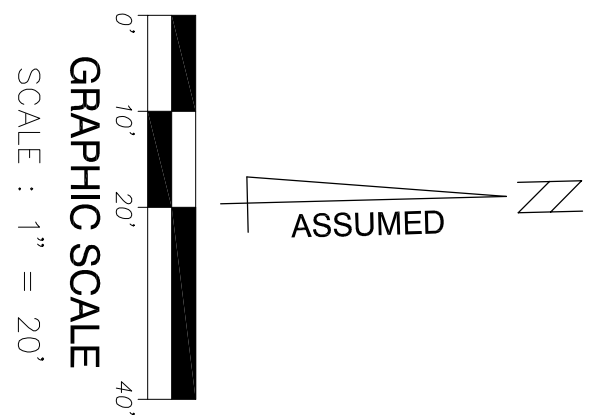

REVISIONS	BY

TOPOGRAPHIC SURVEY
 of
 PORTION OF S.W. 9th STREET, S.W. 10th STREET, S.W. 11th STREET AND S.W. 12th STREET BETWEEN S.W. 1st AVE. AND S.E. 1st AVE., MIAMI, SECTION 12, TOWNSHIP 54 SOUTH, RANGE 41 EAST MIAMI - DADE COUNTY, FLORIDA
 for
TY LIN INTERNATIONAL

J. Bonfill & Associates, Inc.
 ARCHITECTS, LAND SURVEYORS & MAPPERS
 Florida Certificate of Authorization LB3398
 9360 S.W. 72nd Street Suite 265
 Miami, Florida 33173 (305) 598-8383

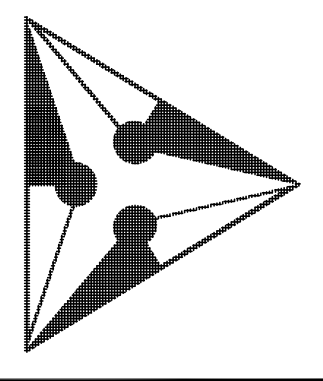

Project: 10-0240
 Job: 10-0240
 Date: 08-24-2010
 Drawn: G.P., J.S.
 Checked: J.B.
 Scale: AS SHOWN
 Field Book: ON FILE
 SHEET 5 OF 9