

MIAMI RIVER

Greenway Regulatory Design Standards



y a z i

50280093.04



Kimley-Horn
and Associates, Inc.

U R G
URBAN RESOURCE GROUP

A DIVISION OF KIMLEY-HORN AND ASSOCIATES, INC.

REVISED DECEMBER 2008

ACKNOWLEDGEMENTS

City of Miami

444 SW 2nd Avenue
P.O. Box 330708
Miami, Florida 33130
(305) 416-1400

PLANNING DEPARTMENT TRANSPORTATION AND CAPITAL IMPROVEMENTS DEPARTMENT

Mayor, Manuel A. Diaz
Commissioner, Angel Gonzalez – District 1
Commissioner, Marc D. Sarnoff – District 2
Commissioner, Joe Sanchez – District 3
Commissioner, Tomas P. Regalado – District 4
Commissioner, Michelle Spence Jones – District 5
City Manager, Pedro G. Hernandez

Trust for Public Land

7900 Red Road, Suite 25
Miami, Florida 33143
(305) 667-0409

Miami River Commission

4600 Rickenbacker Causeway
Miami, Florida 33149-1098
(305) 361-4850

Urban Resource Group

A Division of Kimley-Horn and Associates, Inc.

Urban Design and Landscape Architecture
1691 Michigan Avenue, Suite 400
Miami Beach, Florida 33139
(305) 673-2025

Updated December, 2008

TABLE OF CONTENTS

EXECUTIVE SUMMARY	1
PROJECT BOUNDARY MAP	4
GENERAL STANDARDS	5
Overall Intent	6
General Standards Plan/Section.....	7
General Standards Section Outline	9
Zone 1 – Street Right-of-Way Standards	11
Zone 2 – Architectural Facade Treatments	22
Zone 3 – Riverwalk Standards	39
Zone 4 – Connectors	49
LOWER RIVER	60
Overall Intent	61
Overall Plan/Section	62
Section Outline.....	64
Zone 1 – Street Right-of-Way Standards (Refer to General Standards).....	65
Zone 2 – Architectural Facade Treatments	66
Zone 3 – Riverwalk Standards (Refer to General Standards).....	72
Zone 4 – Connectors(Refer to General Standards).....	73
MIDDLE RIVER	74
Overall Intent	75
Overall Plan/Section	76
Section Outline.....	78
Zone 1 – Street Right-of-Way Standards (Refer to General Standards).....	79
Zone 2 – Architectural Facade Treatments	80
Zone 3 – Riverwalk Standards (Refer to General Standards).....	86
Zone 4 – Connectors (Refer to General Standards).....	87

UPPER RIVER	88
Overall Intent	89
Overall Plan/Section	90
Section Outline.....	92
Zone 1 – Street Right-of-Way Standards (Refer to General Standards).....	93
Zone 2 – Architectural Facade Treatments	94
Zone 3 – Riverwalk Standards (Refer to General Standards).....	98
Zone 4 – Connectors (Refer to General Standards).....	99

APPENDIX

- Appendix A – Plant Material
- Appendix B – Hardscape Material
- Appendix C – Site Furniture
- Appendix D – Wayfinding Program
- Appendix E – Crime Prevention Through Environmental Design
- Appendix F – Plant Maintenance/Tree Protection
- Appendix G – Description of Jurisdictional Activities and Required Approvals
- Appendix H – Case Studies

EXECUTIVE SUMMARY

Introduction and Overview

In recent years, The City of Miami along with the Miami River Corridor has experienced unprecedented development. This surge in economic forces has already begun to reshape the margins of the lower river, and is steadily moving northwest up the river. Regardless of what the near future will bring to Miami's housing market, the Miami River is now a recognized valuable resource for Miami's development scene, and will continue to be so for years to come.

The Miami River Greenway is a linear connection that provides continuity of pedestrian access along both sides of the river. The Greenway is a public green space that needs to be both preserved and expanded for Miami's citizens and visitors.

The Greenway will run along the rights-of-way of both North and South River Drives, primarily linking people and places along the river together and serving as a primary unifying element for the corridor. The Miami River Greenway is an integral part to the success of the overall Miami River Corridor's

development success. Now in its first phase of construction, the Greenway will eventually extend from Biscayne Bay to the NW 36th Street/NW 40th Avenue area. The Greenway Corridor is comprised of four integral parts:

- Public right-of-way
- Private development
- Riverwalk
- Connectors from right-of-way to the riverwalk

These elements are all tied together in the fabric of the Miami River. Their success depends on each other; hence this document treats these four elements as one unified corridor.

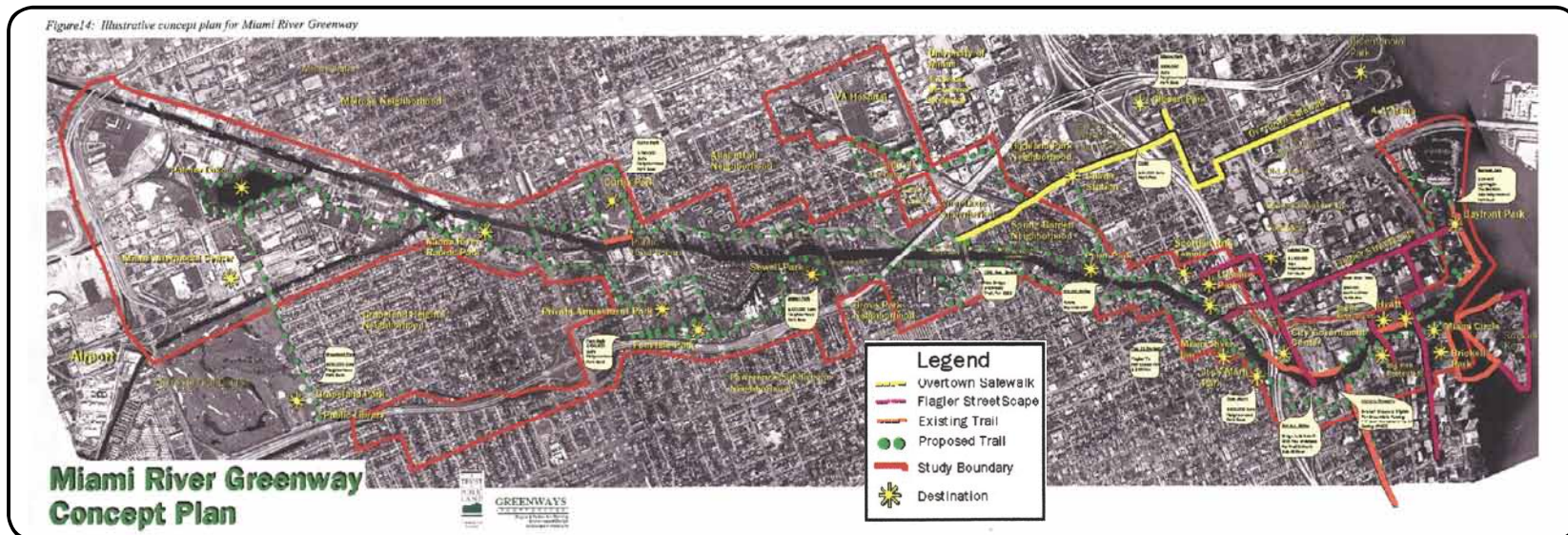

The Miami River action plan is one of the foundation documents for the Regulatory standards.

Purpose of Regulatory Standards

The main purpose of the Miami River Greenway Regulatory Design Standards is to establish a unified set of design standards for the future development of the Miami River Greenway Corridor. This objective is realized through the implementation of these standards for both public and private development so that as the river community grows, its identity and sense of place is maintained.

The Miami River Greenway is a diverse corridor made up of many unique elements such as marine industrial business, single-family housing developments, parks and open spaces, an influx of high-rise condominiums. This diversity is a welcomed quality of the river, representing its ever-evolving nature, and evolution experienced by all great urban river corridors. It is the intent of this document to capture this unique compilation of uses and spaces, and develop standards for a vocabulary of visual elements that are direct representations of this diverse character existing along the Greenway. This design language in turn, helps strengthen the overall image of the Miami River Greenway Corridor, invoking a sense of identity and character to the users as they travel down the corridor.

These standards are designed for developers, design professionals, government agencies, public officials, and the general community to guide the character of both public and private development as it occurs along the river.

The design principles established within this document are based on proven urban design principles and existing similar urban scenarios taken from urban areas around the United States and the world. These principles focus on the following primary objectives and are consistent with the principles set forth in New Urbanism:

- Pedestrian friendly design
- Establishment of a neighborhood identity
- Vibrant, active street fronts
- Diverse and meaningful architecture and urban design
- Establishment of urban green spaces
- Creation of great urban streets

The elements included in this document support these objectives. The result is a cohesive set of regulatory standards that together, help emphasize the identity of the Miami River Corridor. The list of design elements that this document includes ranges from public sector related items such as sidewalks, landscape, and street furniture, to architectural façade related items such as awnings, arcades, openings, setbacks, and building materials to name a few.



The Miami River Greenway corridor includes streetscapes, private development, the riverwalk (shown above) and connectors between the streetscape and riverwalk.

With the surge in private sector development, the question of public accessibility to the river has been brought to the forefront. Miami's waterfront is a priceless resource that must not be lost to the general public. As a result of this, the City of Miami is perusing the inclusion of two primary elements in future ordinances for the river. First, that the existing 50 ft. setback requirement as established in the City's charter for areas along the river, south of 5th street be extended for the entire River Corridor (excluding marine dependent and marine industrial uses). Second, that a 20 ft. wide minimum access corridor be provided between two properties to allow pedestrian connectivity from and to the riverwalk.

MIAMI RIVER Greenway Regulatory Design Standards

How to use this Document

The Miami River Greenway Regulatory Design Standards is organized so that the user can easily navigate to the sections relevant to their project. In order to facilitate this process this document has been subdivided into four major segments:

- General Standards
- Lower River Standards
- Middle River Standards
- Upper River Standards

As defined in previous studies, the Miami River Corridor can be divided into distinct areas based on distinctive characteristics found along the river: The structure of this document is established around these three primary areas.

- Lower River (Biscayne Bay to NE 5th Street)
- Middle River (NE 5th Street to NW 27nd Avenue)
- Upper River (NW 27nd Avenue to Salinity Damn)

Each of these areas consists of a unique urban fabric, there are unifying elements found throughout. While the lower river may be characterized by more high-rise development than the upper river which is a mix of marine industrial uses and lower density residential, there are fundamental unifying characteristics that bind these three areas into one corridor. These are the river itself, and the abutting roadways. These powerful linear connections serve to unify the Miami River Corridor and essentially transform it into a district made up of smaller neighborhoods as is defined in the Miami River Corridor Urban Infill Plan.

The user of this document will see that the majority of the design elements are found within the “general standards” section of the document. This emphasizes the concept brought forth by the previous studies that the river is a unified and cohesive corridor inclusive of a diversity of uses and spaces. Elements that are particular to an area (i.e. the lower river) are found in the section of the document reserved for that particular area.

This document is intended to be a guide for design along the river. It is not a land use plan nor is it an ordinance. There are no regulations that deal with zoning, land use, height, mass, FAR or other volumetric requirements of a property. The extent of these standards focuses on the façade elements of buildings, setbacks along the riverwalk and streetfront, and the street and riverwalk corridors. Additionally, it is the intent of these standards to develop design envelopes from which users can feel free to design unique spaces and facades, rather than restrict design to a preconceived image or style.

PROJECT BOUNDARY MAP

The subdivided project boundaries have been determined through analysis of land use, physical characteristics, and function.

The Lower River includes the downtown area, and is dominated by high density commercial and residential development. It extends from Biscayne Bay to the 5th Street Bridge.

The Middle River is characterized by residential neighborhoods and marine-related businesses. It extends from the 5th Street Bridge to the 27th Avenue Bridge.

Finally, the Upper River consists mainly of industrial sites and water dependent business. It extends from the 27th Avenue Bridge to the Salinity Dam.

Although these three areas have significantly different uses, the standards set forth in this document will create a cohesive design language to link the three distinct regions while maintaining their unique character.

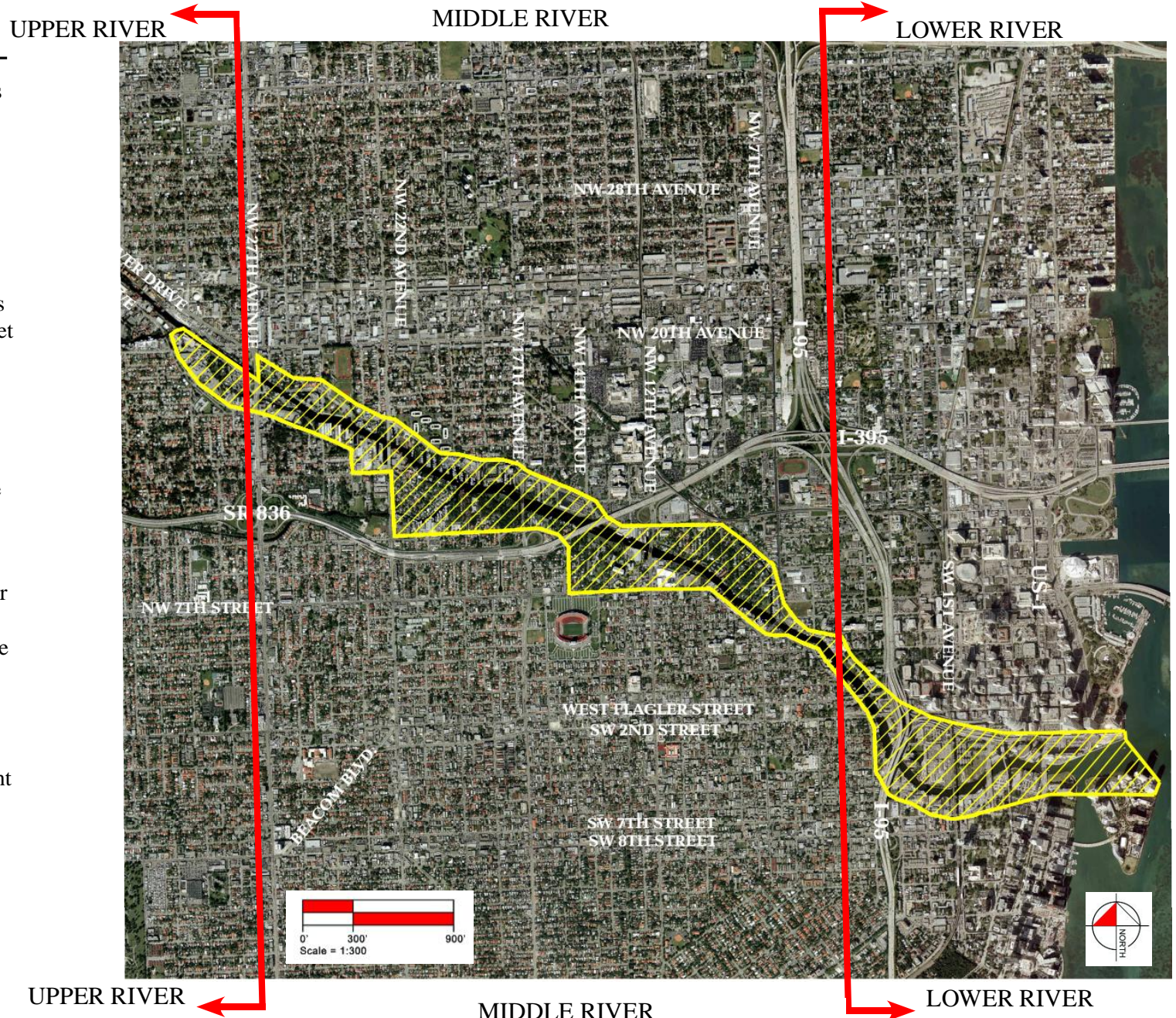

GENERAL STANDARDS

GENERAL STANDARDS

Introduction

Background/Intent

The general standards are those elements that are similar throughout the entire Miami River corridor. This group of elements represents the majority of design components from both the public and private realms. This results from the primary purpose of these standards which is to unify the Miami River corridor, as it passes through the various neighborhoods of the city, by establishing one unified design language. In the following sections of this document, specific elements pertaining to the lower, middle and upper river areas will be identified that apply solely to each of those areas.

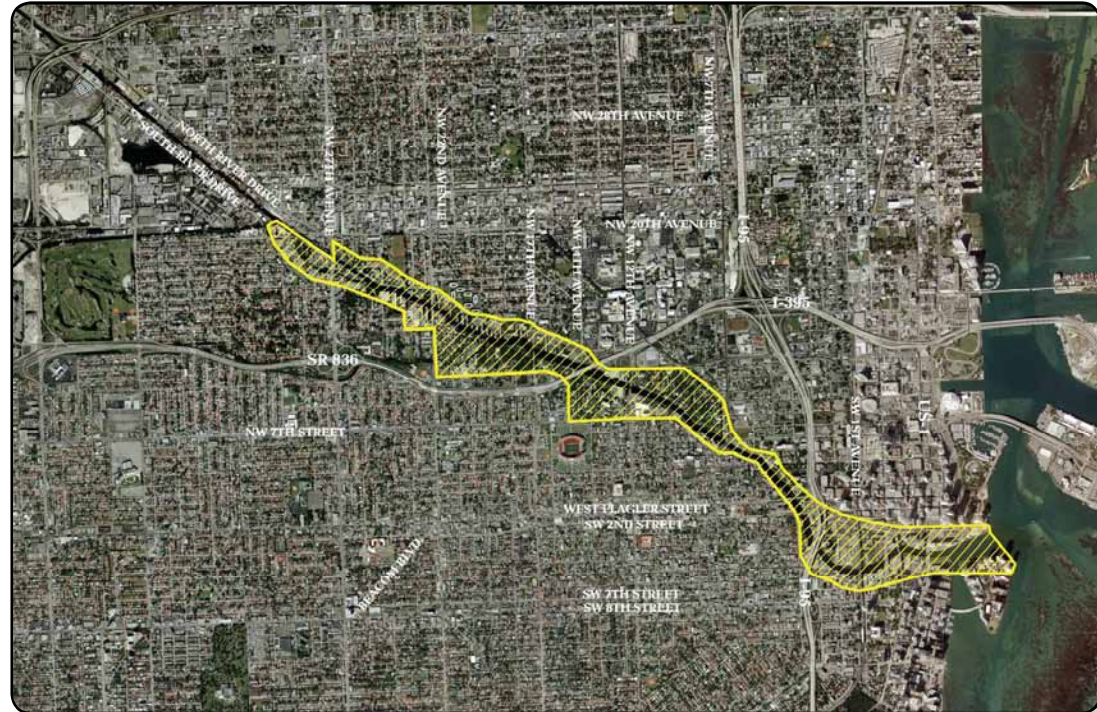

Key Map – The general standards apply to the entire Miami River corridor study area. For a more detailed map refer to page 4.

TYPICAL RIVER CORRIDOR STUDY AREAS

Introduction

The overall plan and section shown on the following page establishes the general physical criteria for the various components within each area of the River, including:

- Right-of-way
- Private Property
- Riverwalk
- Connectors

The purpose of the overall plan and section is to give the user a comprehensive understanding of the desired character of each subarea. It is not intended to represent the only possible scenario. The proceeding section will focus on each individual component of the overall cross-section and plan, and develop specific design standards to guide future development, both public and private, along the Miami River Corridor.

GENERAL STANDARDS – STUDY AREAS

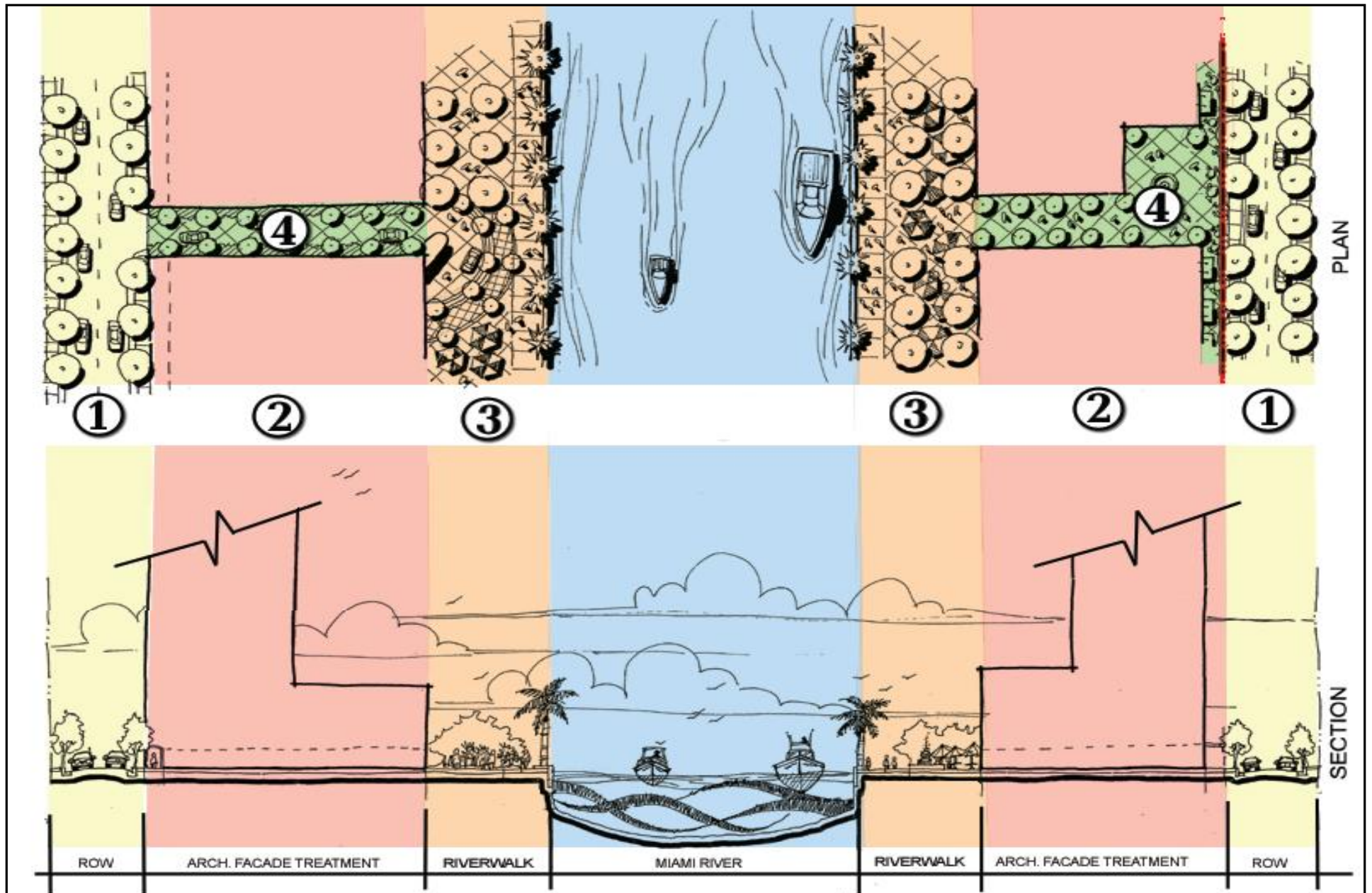

GENERAL STANDARDS SECTION OUTLINE

To User:

This page contains a 'cheat sheet' for guiding the user through this chapter of the workbook. Each zone has a list of design elements that is included within that particular zone. Each zone is also color coded. The color is shown on the edges of the pages that belong to that zone.

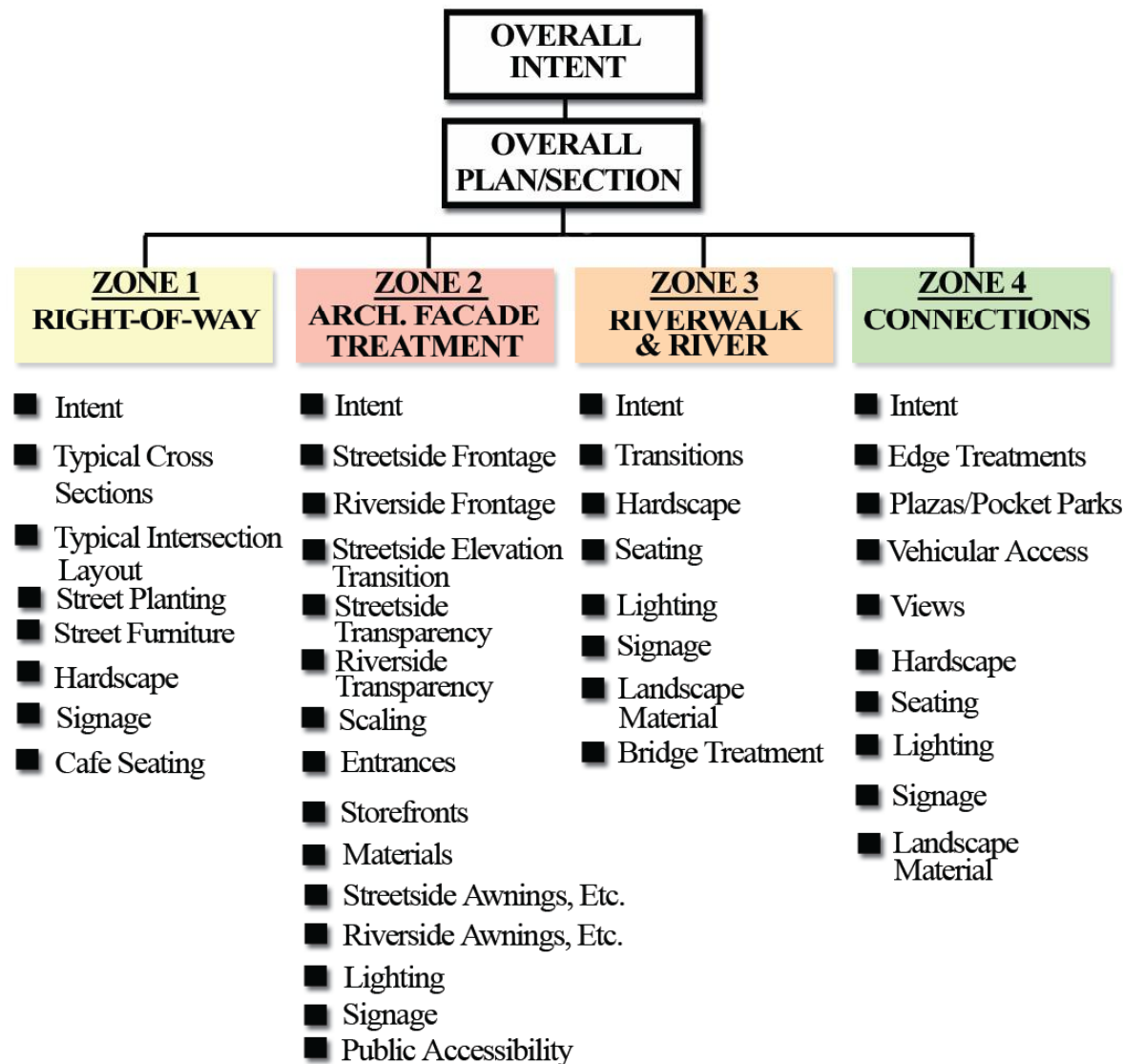

ZONE 1 – STREET RIGHT-OF-WAY

ZONE 1 – STREET RIGHT-OF-WAY

Overall Background/Intent

The right-of-ways included in this project area are critical components that shape the overall image and identity of the Miami River Corridor. This section focuses on unifying the design for all of the different elements that make up the streetscape.

Refer to the Miami River Greenway Phase I Construction Documents for specific layout for the Lower River. A copy may be obtained by contacting the City of Miami Department of Capital Improvements.

Included in this section are the following standards:

- Typical Cross Section for 40' Right-of-Ways
- Typical Cross Section for 50' Right-of-Ways
- Typical Cross Section for 60' or greater Right-of-Ways
- Typical Intersections
- Street Planting
- Street Furniture
- Hardscape
- Cafe Seating

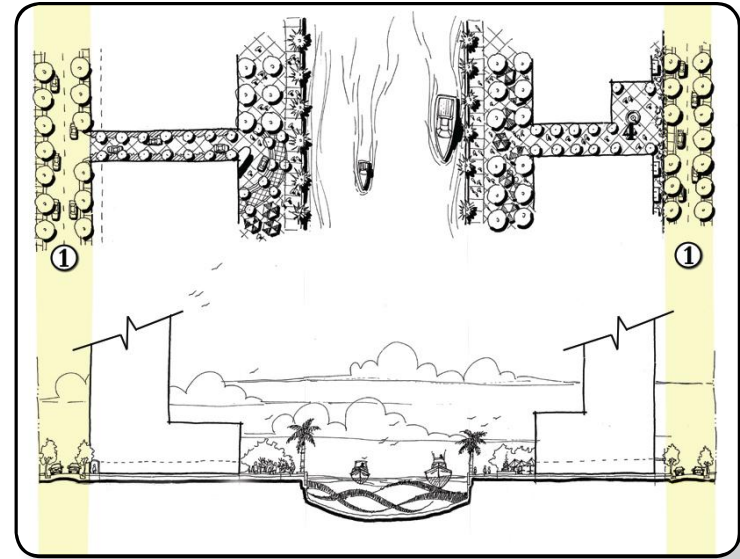

Key Map



This streetscape reads as a cohesive design. All of its elements are thought of as part of a whole and contribute to the overall identity of the corridor.

ZONE 1 – STREET RIGHT-OF-WAY

Refer to the typical plan/section views on page 15 to accompany this matrix.

STANDARD RIGHT-OF-WAY ELEMENT MATRIX			
	40' ROW (Non-Greenway Street)	50' ROW	60' ROW
On street parking	None	- One side (opposite Greenway) only. - Parallel parking only.	- One side (opposite Greenway) or both sides. - Parallel parking only - 8.5' x 22' min. dimension.
Travel lanes	(2) – 10' Lanes	(2) – 10' Lanes	(2) – 11' Lanes with optional turn lane
Sidewalk	4.5' Clear (min.) Both sides.	- Greenway side 7.8' clear (min.) - Non-Greenway side 5' (min.)	- Greenway side 7.8' clear (min.) - Non-Greenway side 5' (min.)
Landscape verge	4.5' (min.)	- Greenway side - 7' (min.) - Non-Greenway side - None (except for parking islands.)	- Greenway side 7' (min.) - Non-Greenway side 5' (min.)
Median	None	None	- Optional 12' min. to include landscape material - trees 30' O.C.
Landscape islands	None	- 7' wide x 10' long (min.) shall include 1 tree or palm (min.) with groundcover.	- 7' wide x 10' long (min.) shall include 1 tree or palm (min.) with groundcover.
Driveways	24' (max.) width	24' (max.) width	24' (max.) width
Handicap ramps	Per FDOT Index 315 (2004 edition)	Per FDOT Index 315 (2004 edition)	Per FDOT Index 315 (2004 edition)
Curb/gutter	1.5' (modified 'F' curb)	- 1.5' (modified 'F' curb) - 1.5' (modified valley gutter) adjacent to on-street parking. - 5' ('D' curb) adjacent to parking.	- 1.5' (modified 'F' curb) - 1.5' (modified valley gutter) adjacent to on-street parking. - 5' ('D' curb) adjacent to parking.
Tree spacing	30' O.C. (max.)	- 30' O.C. (max.) Greenway side - 54' O.C. (max.) non-Greenway side between 2 parking spaces.	- 30' O.C. (max.) Greenway side - 54' O.C. (max.) non-Greenway side between 2 parking spaces.

STANDARD RIGHT-OF-WAY ELEMENT MATRIX			
	40' ROW	50' ROW	60' ROW
Street Furniture	<p>Light Poles: FPL decorative package – Washington fixture or tear drop fixture (depending on existing utilities.) – Black color.</p> <p>Benches: Plainwell bench by Landscape Forms (or approved equal) – Black frame with Ipe seat. Greenway custom medallion to be placed on back rest. Refer to appendix ‘C’. Minimum of one bench per block on both sides of the street.</p> <p>Trash Receptacle: Plainwell trash receptacle by Landscape Forms (or approved equal.) – Black color. Minimum two per intersection.</p> <p>Bicycle Rack: Pi Rack by Landscape Forms (or approved equal.) – Black color. One per 500 LF minimum.</p>	<p>Light Poles: FPL decorative package – Washington fixture or tear drop fixture (depending on existing utilities.) – Black color.</p> <p>Benches: Plainwell bench by Landscape Forms (or approved equal) – Black frame with Ipe seat. Greenway custom medallion to be placed on back rest. Refer to appendix ‘C’. Minimum of one bench per block on both sides of the street.</p> <p>Trash Receptacle: Plainwell trash receptacle by Landscape Forms (or approved equal.) – Black color. Minimum two per intersection.</p> <p>Bicycle Rack: Pi Rack by Landscape Forms (or approved equal.) – Black color. One per 500 LF minimum.</p>	<p>Light Poles: FPL decorative package – Washington fixture or tear drop fixture (depending on existing utilities.) – Black color.</p> <p>Benches: Plainwell bench by Landscape Forms (or approved equal) – Black frame with Ipe seat. Greenway custom medallion to be placed on back rest. Refer to appendix ‘C’. Minimum of one bench per block on both sides of the street.</p> <p>Trash Receptacle: Plainwell trash receptacle by Landscape Forms (or approved equal.) – Black color. Minimum two per intersection.</p> <p>Bicycle Rack: Pi Rack by Landscape Forms (or approved equal.) – Black color. One per 500 LF minimum.</p>

ZONE 1 – STREET RIGHT-OF-WAY

Typical Cross-Sections

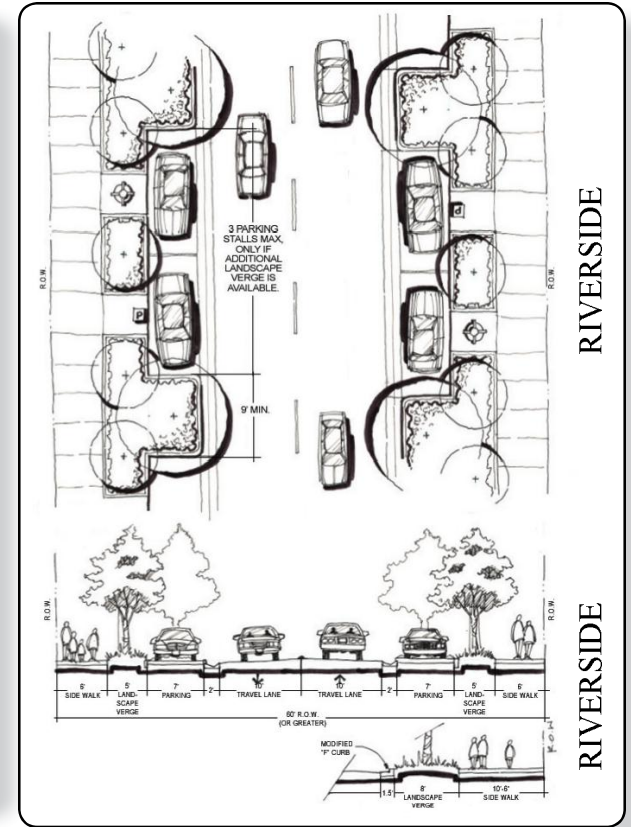
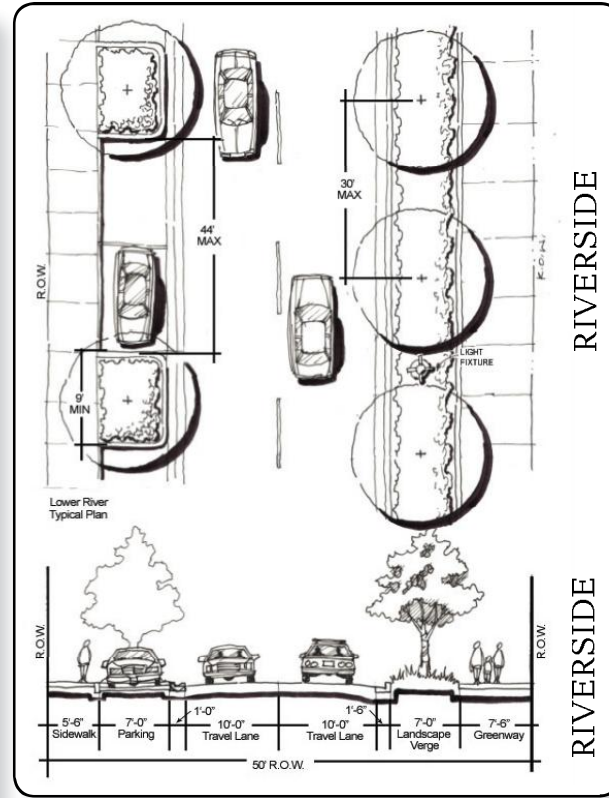
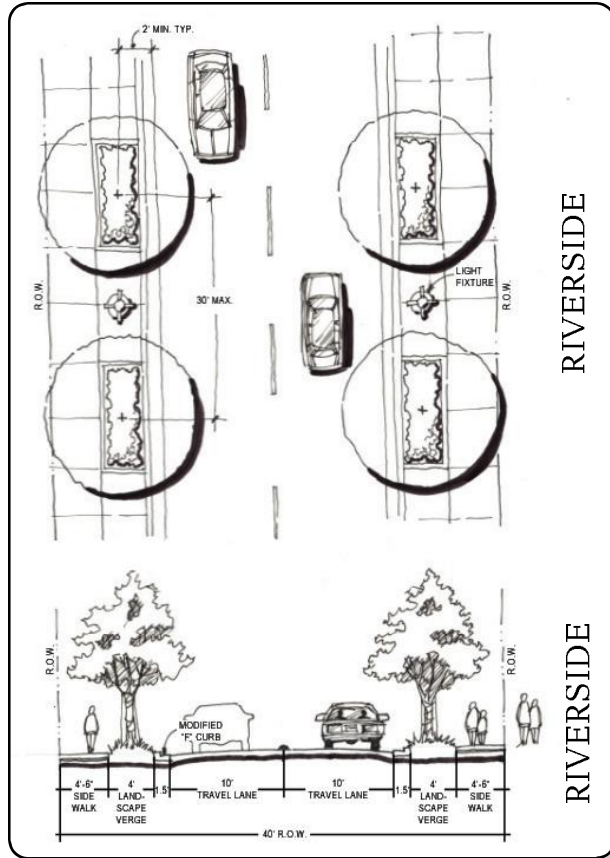

ZONE 1 – STREET RIGHT-OF-WAY

Typical Intersection Layout

Background/Intent

Intersections are key components of the neighborhood. They present opportunities for gathering areas, art displays, additional beautification, and focal points. It is the intent of this document to highlight intersections along the greenway corridor to serve as a gateway into the corridor by establishing a distinct and identifiable image.

Standard

All street intersections along the Miami River Greenway shall incorporate colored concrete crosswalks along the greenway side, accent palms or flowering trees on all corners, and wayfinding markers on the greenway side.

This can be accomplished applying the following criteria:

- Refer to appendix for special streetscape details approved by City of Miami
- Refer to hardscape palette for all allowable hardscape materials (Appendix B)
- Refer to landscape palette for acceptable landscape materials (Appendix A)

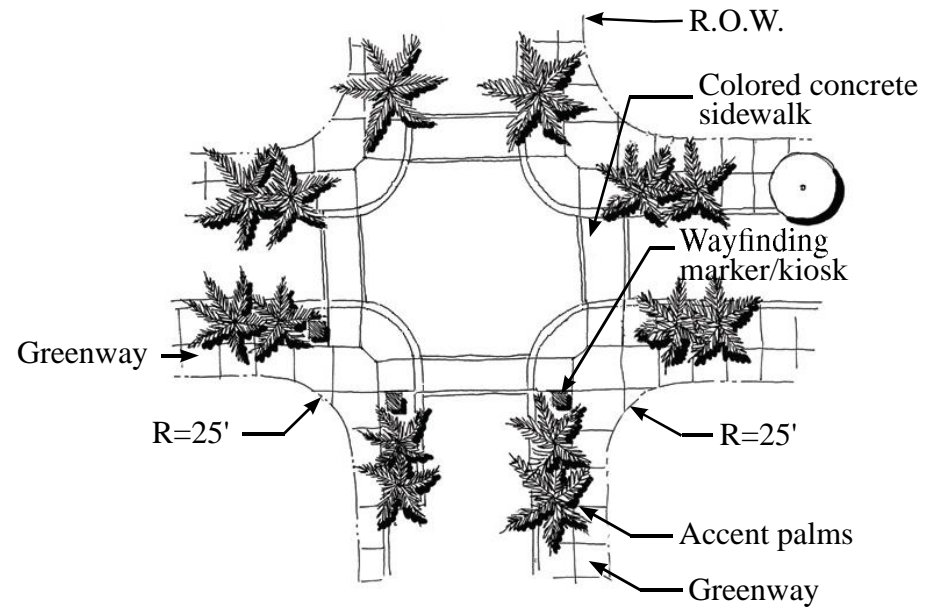

Typical Intersection Layout



Typical return-curb style ramp with landscape knuckles

ZONE 1 – STREET RIGHT-OF-WAY

Street Planting

Background/Intent

Street planting is a crucial part in defining the image of the area and providing much-needed shade to sidewalk and outdoor seating areas. The intent of this document is to provide minimum standards for street planting, including defining maintenance standards for upkeep of public planting.

Standard

Street trees shall be planted no greater than 30' on center unless planted in between parallel parking spaces. In this case, they shall be planted no further than 55' on center. Minimum distance from face of curb to edge of tree trunk shall be 2'. All street trees shall be shade trees or palms, if specifically approved by the city of Miami, per the plant palette, provided in Appendix A of this document. Minimum planting beds for trees and palms shall consist of 108 cubic feet of volume. Minimum depth of planting beds shall be 3'. All tree pits shall be 100% covered with either shrubs or groundcover. Maximum shrub spacing shall be a maximum of 30" on center. A 6" mulch ring shall be maintained along the perimeter of all planters. Maximum groundcover spacing shall be 18" on center.

This can be accomplished applying the following criteria:

- Refer to Appendix F for maintenance criteria and tree protection details.
- Refer to Appendix A for approved plant palette.
- Alternative plantings shall be allowed when:
 1. It conflicts with existing utilities (overhead and underground). Coordinate with City of Miami.
 2. FPL standards for planting under power lines shall be implemented where appropriate.

IMAGE 1

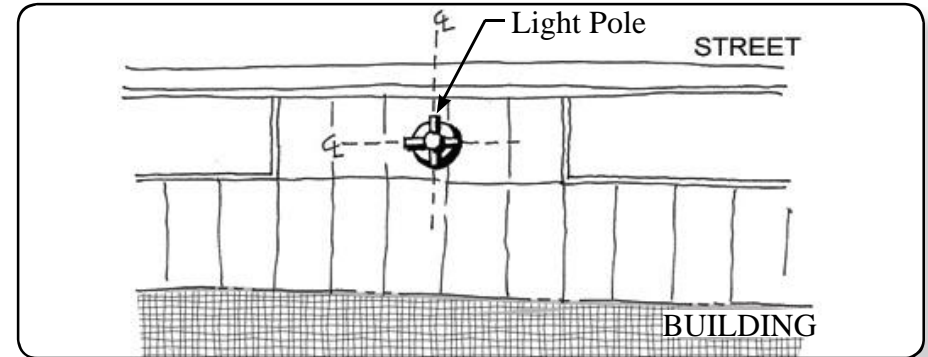

IMAGE 2

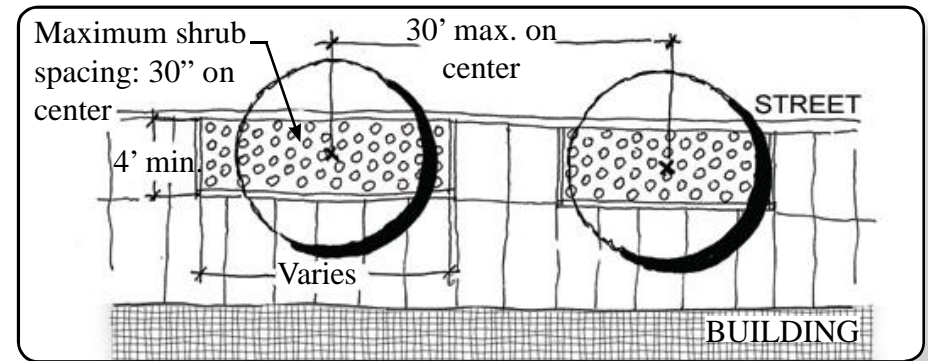
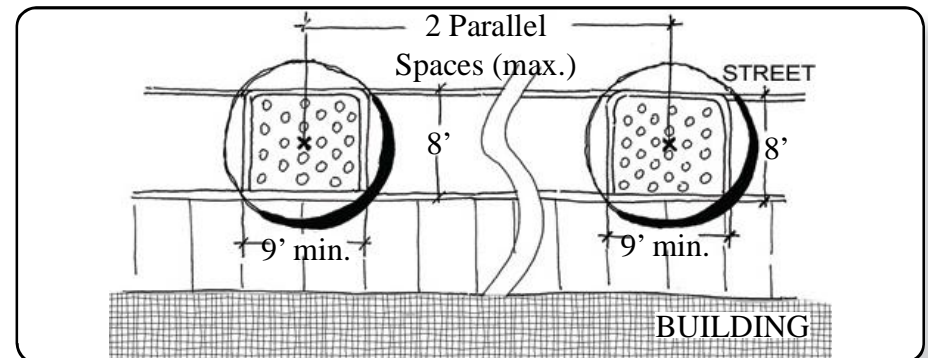

IMAGE 3



Typical Plant Spacing Diagrams

ZONE 1 – STREET RIGHT-OF-WAY

Street Furniture

Background/Intent

Street furniture serves to both provide users of the street with added amenities and safety as well as to contribute to the overall image of the streetscape. Site furniture includes benches, trash receptacles, parking stations, light poles, mailboxes, newsracks, bike racks, and other approved vertical obstructions.

It is the intent of this document to establish a palette of approved streetscape furniture and to suggest locations for placement along the street to provide appropriate usage and safety.

Standard

All site furniture as described above shall be located within the landscape verge, off of the unobstructed sidewalk area as defined in the typical cross-sections. There shall be a minimum of one bench every 200 linear feet on either side of the street. There shall be a trash receptacle a minimum of every 150 linear feet on both sides of the street. There shall be a bicycle rack a minimum of every 500 linear feet on either side of the street. All street lights shall be spaced to provide a minimum of 1 footcandle throughout the public corridor.

This can be accomplished applying the following criteria:

- Refer to site furniture palette in Appendix A for approved designs.
- Refer to right-of-way element matrix on sheet 13-14.
- Street furniture shall be placed as to allow clear access to parked cars.
- Minimum distance from face of curb to edge of street furniture element shall be 2'.
- All other streetscape elements such as mailboxes, parking stations, news racks, fire hydrants and traffic signal boxes shall adhere to these standards.

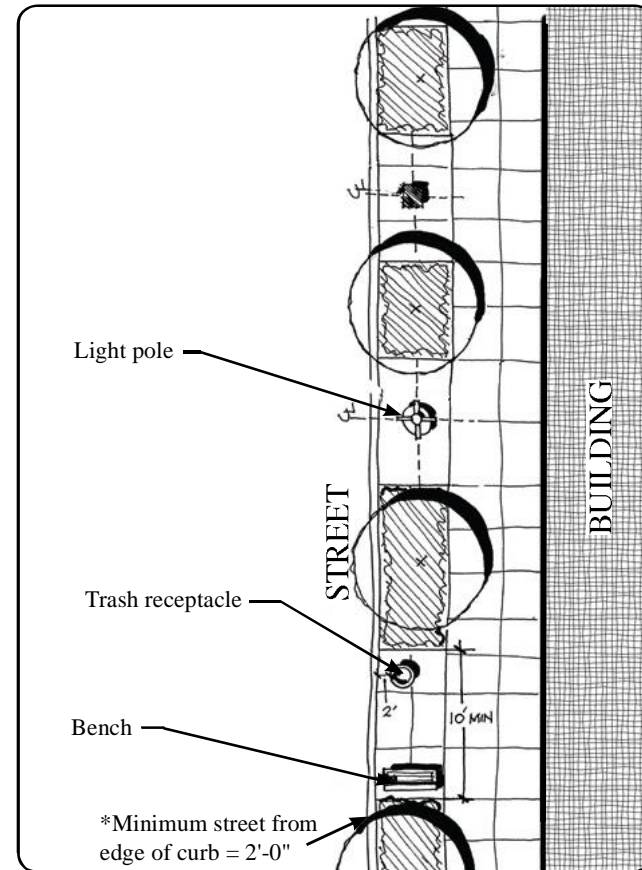

Typical street furniture layout. All street furniture is situated along the landscape verge leaving the sidewalk unobstructed.

ZONE 1 – STREET RIGHT-OF-WAY

Hardscape

Background/Intent

In order to create a cohesive design throughout the Miami River Corridor, it is imperative that consistent hardscape materials are used, which will be both aesthetically pleasing and maintenance-friendly. It is the intent of these standards to select a consistent material type for public sidewalks which will help define the overall image of the corridor as well as survive the challenges of a harsh urban environment.

Standard

All sidewalks along the greenway side of the right-of-way shall be broom finish, integral colored concrete, LM Scofield color number C-12(Mesa Beige) or approved equal. All other sidewalks shall be standard grey concrete.

This can be accomplished applying the following criteria:

- Hardscape surfaces made of color concrete shall be integral color, not surface color—refer to Appendix B.
- Designer may provide alternative hardscape materials and color to accentuate the front entrances of buildings per City of Miami approval.

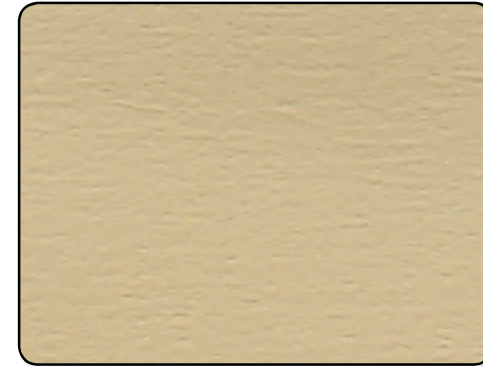

The C-12 Mesa Beige color from Scofield is the approved color concrete mixture for the Miami River Greenway.



This property accentuates its main entrance with a different hardscape design extending out into the public sidewalk.

ZONE 1 – STREET RIGHT-OF-WAY

Signage

Background/Intent

Signage is an important element of the public realm that must be regulated and made to conform to the desired image and character of the corridor. Signage includes both traffic related and wayfinding elements that orient users where they are in the corridor. It is the intent of these standards to develop a cohesive identity to all of the signage elements with the public realm and establish typical locations.

Standard

All signage as defined in the intent above shall conform to the standards set forth herein.

- All public access to and from the riverwalk shall be marked with a directional sign. Such sign shall read “Public Shore” and shall include a key map showing the relevant location along the river.
- Historic and/or environmental markers shall be located at appropriate areas along the riverwalk to ensure clear pedestrian interaction.
- Refer to Appendix D

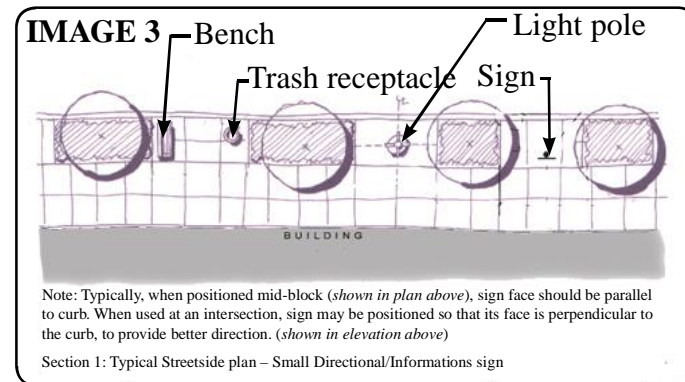
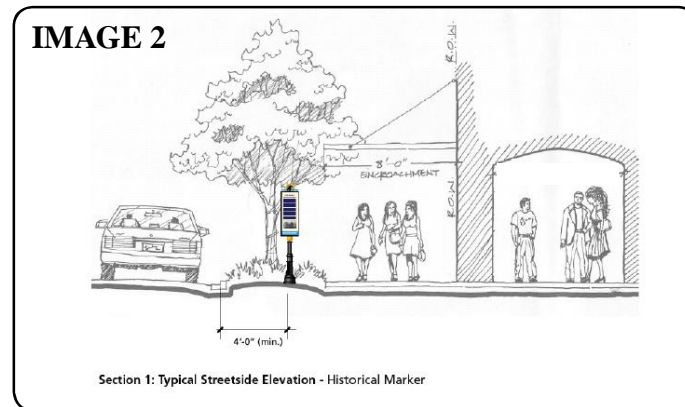
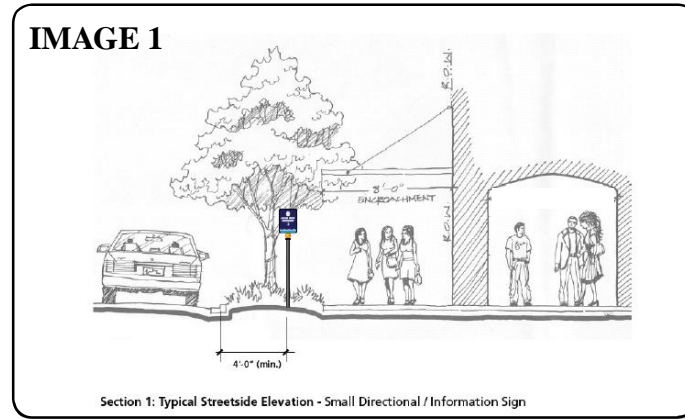

ZONE 1 – STREET RIGHT-OF-WAY

Cafe Seating

Background/Intent

Cafe seating is an amenity that can be enjoyed year-round in south Florida. It draws activity and enhances vibrancy of the corridor. An important consideration is to allow for free and clear pedestrian traffic while providing for sufficient seating areas to occur.

Standard

A minimum of 5 feet of obstruction-free pedestrian passage shall be required for any business with restaurant cafe seating.

This can be accomplished applying the following criteria:

- Businesses shall define their seating boundaries with planters and other decorative edge treatments.
- No elements shall encroach into the 5 foot clear zone. This includes chairs, tables, outdoor news stands and planters.
- Cafe seating may extend into the public Right-of-way on the streetside provided that the minimum 5' clear zone is provided.
- Cafe seating shall not encroach into the 15' Riverwalk clear zone.
- A minimum 1.5' clear zone shall be established between a parallel parking space or travel lane and outdoor seating.

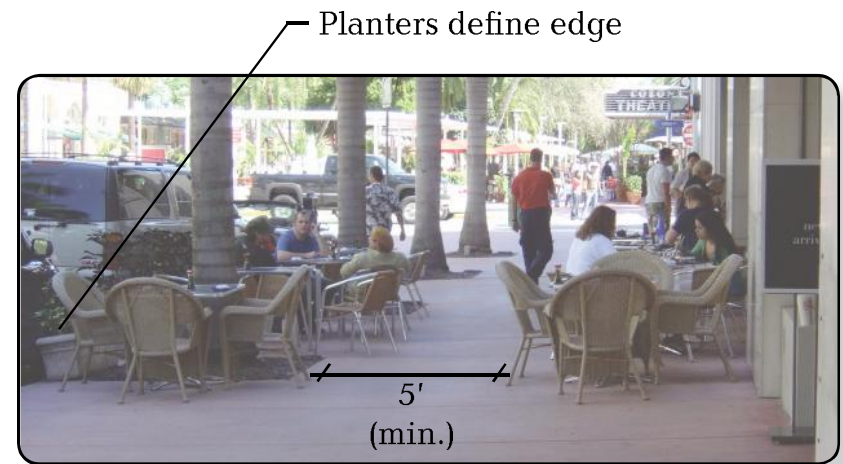

The cafe seating shown above provides obstruction-free Right-of-way pedestrian passage through the seating area.

ZONE 2 – ARCHITECTURAL FACADE TREATMENTS

ZONE 2 – ARCHITECTURAL FACADE TREATMENTS

Background/Intent

The private property development along the Miami River should relate to the public realm in scale and character in order for the corridor to achieve its maximum potential for urban quality. The following section focuses on developing standards for the facade elements abutting the right-of-ways of the Miami River corridor and not in building volume and use.

Included in this section are the following standards:

- Streetside Frontage
- Riverside Frontage
- Streetside Elevation Transition
- Streetside Transparency
- Riverside Transparency
- Scaling
- Entrances
- Storefronts
- Materials
- Streetside Awnings, Arcades and Colonnades
- Riverside Awnings, Arcades and Colonnades
- Lighting
- Signage
- Public Accessibility



This Riverfront property engages the public realm with seating, shade and active store fronts.

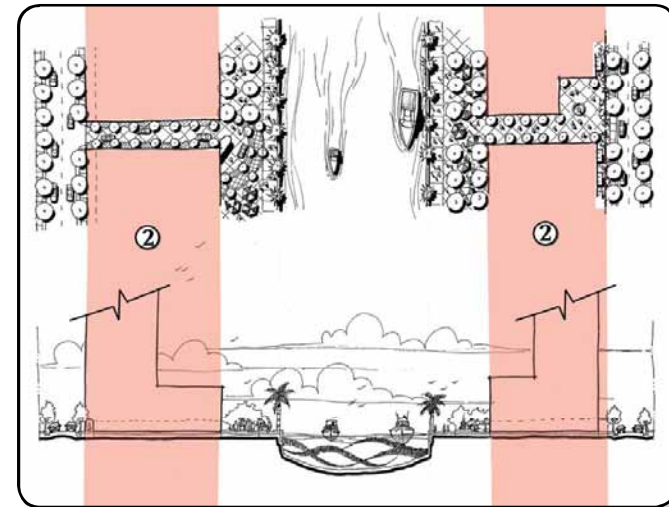

Key Map

ZONE 2 – ARCHITECTURAL FACADE TREATMENTS

Streetside Frontage

Background/Intent

The intent for all successful streetscapes include active building uses framing the public corridor. This relationship is essential for creating activity on the street. Establishing frontage requirements is to create a vibrant and active street by encouraging interaction between the street and abutting uses. Frontage pertains to active, transparent use along the building's footprint.

Standard

For all non-industrial use buildings, a minimum of 65% of the building footprint shall have a maximum of a 10' setback. (Refer to streetside setback requirements for each area.)

This can be accomplished applying the following criteria:

- All abutting properties shall have the main entrance along the street and with the 10' setback.
- Where garages or other non-active uses are required and cannot be moved to the side, they must be screened properly according to these guidelines.
- Vehicular access shall be limited where the building fronts the R.O.W. Vehicular traffic shall be redirected to the side of the building when possible.
- Includes colonnades/arcades in front of interior open spaces.

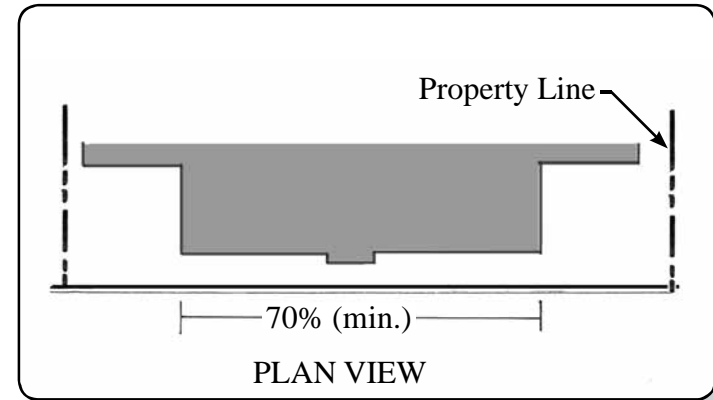

Any building located along the street shall have a minimum of 70% street frontage.



By maximizing frontage, businesses will have more interaction with the street and with pedestrians.

ZONE 2 – ARCHITECTURAL FACADE TREATMENTS

Riverside Frontage

Background/Intent

Like the street, the riverwalks success as a vibrant pedestrian space will be the product of the relationship between the corridor and the adjacent buildings. The intent of establishing frontage requirements is to create a vibrant and active riverwalk by encouraging interaction between the riverwalk and abutting uses. Frontage pertains to active, transparent use along the building's footprint.

Standard

For all non-industrial use buildings, a minimum of 80% of the building footprint shall abut the riverwalk.

This can be accomplished applying the following criteria:

- Refer to elevation transparency requirements.
- No vehicular circulation (excluding emergency vehicles) shall be permitted with in the riverwalk setback areas.

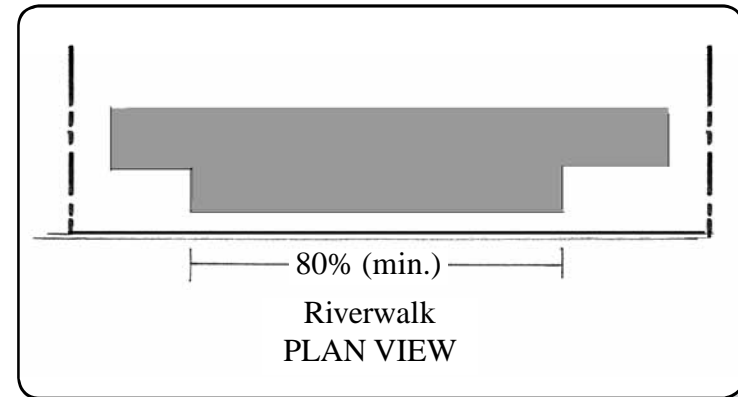

Any building located along the riverwalk shall have a minimum of 80% street frontage.



By maximizing frontage, businesses will have more interaction with the street and with pedestrians.

ZONE 2 – ARCHITECTURAL FACADE TREATMENTS

Streetside Elevation Transition

Background/Intent

Buildings must be made more accessible to all, not only to adhere to ADA codes, but to encourage pedestrian flow and connectivity to and from the street. Designers should strive to create gradual transitions from the street to the entryway of the buildings that respond to flood zone requirements.

It is the intent of these standards to enhance the accessibility opportunities of the properties along the river corridor while focusing on the aesthetic connection to the streetscape as well.

Standard

Elevation changes shall be addressed by gradual increments where possible.

This can be accomplished by applying the following criteria:

- The accessible route into the building should not detract from the primary entrance.
- Ramps or other accessibility features shall blend with the architecture in color and in style.
- Designer shall adhere to National American with Disabilities Act of 1992 and current Florida building code requirements.



In cases where abrupt elevation changes are necessary, they should blend into the overall design of the facade as shown in the arcade above.

ZONE 2 – ARCHITECTURAL FACADE TREATMENTS

Streetside Transparency

Background/Intent

Solid frontages without openings will not create the desired interaction and vibrancy along the corridor. A strong visual connection between public streets and interior ground spaces is encouraged to create this interaction.

Standard

For all non-marine industrial zoned properties, the first ten (10) feet of height above the public sidewalk elevation, along the exterior building wall shall contain windows and/or doorways of transparent glass covering a minimum of 60% of the facade areas. In addition, the base of all transparent openings shall be no more than 18 inches above finish floor.

This can be accomplished applying the following criteria:

- Storefront materials shall allow unobstructed views to the inside of the establishment to promote “window shopping.”
- Doors shall be at least 50% clear glass.
- All glass used in storefronts shall be clear (not frosted, textured, or otherwise affected) and provide an unobstructed view of a minimum of six(6) feet into the establishment.
- Storefront of display windows shall not be filled in or blocked in any way.



The building shown above provides fully transparent doors and windows to create an interaction with the street.

ZONE 2 – ARCHITECTURAL FACADE TREATMENTS

Riverside Transparency

Background/Intent

Transparent, active facades promote the desired relationship between the public and private realms along the river corridor. Solid frontages without openings will not create this desired interaction and vibrancy. The intent is to create a strong visual connection between the riverwalk and interior ground spaces.

Standard

For all non-marine industrial zoned Riverwalk properties, for the first ten(10) feet of height above the elevation. Along the exterior building wall shall contain windows and/or doorways of transparent glass covering a minimum of 70% of the wall areas. In addition, the base of all transparent openings shall be no more than 18 inches above finish floor.

This can be accomplished applying the following criteria:

- Storefront materials shall allow unobstructed views to the inside of the establishment to promote “window shopping.”
- Doors shall be at least 50% clear glass.
- All glass used in storefronts shall be clear (not frosted, textured, or otherwise affected) and provide an unobstructed view of a minimum of six(6) feet into the establishment.
- Storefront of display windows shall not be filled in or blocked in any way.



The building shown above provides fully transparent doors and windows to foster interaction with the riverwalk.

ZONE 2 – ARCHITECTURAL FACADE TREATMENTS

Scaling

Background/Intent

The scale of a building is important to unify it to its surroundings and create a more human scale atmosphere. For the lower river especially large towers will be a typical development scenario, it is imperative that the bases of these towers be articulated to proportionally scale to pedestrian uses. This also applies to other, smaller-scale developments along the river corridor.

Standard

Buildings shall be articulated to include changes in the facade plane to proportionally scale the building to the street and its surrounding areas.

This can be accomplished applying the following criteria:

- Facades shall avoid large, blank surfaces and non-modular panels.
- Repetition of vertical and horizontal members are encouraged at proportional intervals.
- Facade plane changes are encouraged at proportional intervals.



This building illustrates a good example of bringing the building facade down to the pedestrian scale, by a simple change in building materials and modifications to the facade plane.

ZONE 2 – ARCHITECTURAL FACADE TREATMENTS

Entrances

Background/Intent

When one approaches a business, a restaurant, or a retail establishment, the entrance is the most important part of that experience. By establishing changes in material, articulation, and depth, entrances are emphasized and become true focal points for the building.

Standard

Entrances into buildings shall be articulated to create a focal point, that is distinguishable in appearance from the rest of the facade.

This can be accomplished applying the following criteria:

- Entrances shall be articulated with different building materials and changes in massing and scale.
- Entrances shall be set back a minimum of 6" from the building facade.
- Corner entrances shall be oriented to engage the corner.



The entrance shown above is set back from the facade and is articulated to highlight its significance.



The facade shown above clearly differentiates the main entrance to the building by a change in mass, form and materials.

ZONE 2 – ARCHITECTURAL FACADE TREATMENTS

Storefronts

Background/Intent

In so many great urban streets, the success and life of that particular corridor can be attributed to the general appearance of the store fronts that generate the pedestrian activity and use.

By planning the appearance of a storefront correctly, there can be a greater amount of interaction with customers, passers-by, window shoppers and driveby customers. This in turn will generate the type of vibrant use that fuels economic and social growth.

Standard

Storefronts shall be designed to create a high degree of interaction with the adjacent public realm.

This can be accomplished applying the following criteria:

- Storefronts shall be at least 10' high with a minimum of 80% transparent glass to allow for unobstructed views to promote “window shopping.”
- Signage shall not obstruct the glass area.
- Window sills shall be set as close to the ground as allowed by flood criteria.
- Entrances shall be highlighted in storefronts.
- Window displays shall be allowed, but must be simple and maintained to a proper level of display by the store per planning directors discrepancy.
- The storefront shall be set back from the building facade or columns 6"-12" to create depth and shadow lines.

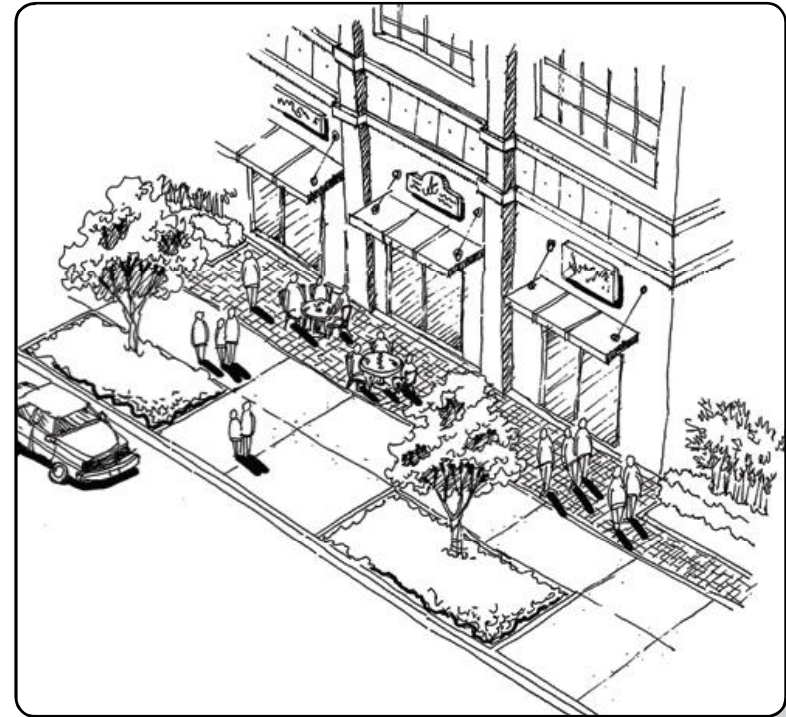

Proper storefront treatment includes ample shading, transparency, signage and lighting.

ZONE 2 – ARCHITECTURAL FACADE TREATMENTS

Materials

Background/Intent

Blank building facades are discouraged when they do not contribute to the vibrancy of the corridor. This is especially true at ground level where there is a greater purpose to engage the street and pedestrians.

The intent of these standards is to establish a palette of materials that respect and embody the local Miami vernacular while allowing for quality and innovative designs throughout the corridor.

Standard

At least (2) different materials shall be used in each building elevation. When used for windows, glass shall not be counted as one of the materials.

This can be accomplished applying the following criteria:

- Acceptable materials should be indicative of Miami’s vernacular and context. Such materials include, but are not limited to, stucco, coquina stone, precast concrete, tile, metal, glass, etc.
- Different materials shall be used to emphasize openings and entrances such as windows and doorways.
- Creative and innovative uses of materials and high quality building materials are encouraged.



These buildings utilize several different materials in the facade in order to enhance its appearance.



Glass



Stone/Marble



Coquina Stone



Ceramic Tile



Stucco



Metal Finish

Above are materials that are permitted and encouraged along the Miami River Corridor.

ZONE 2 – ARCHITECTURAL FACADE TREATMENTS

Streetside Awnings, Overhangs, and Arcades

Background/Intent

Awnings, overhangs and arcades not only provide essential shade for pedestrians, but they are also powerful elements that can greatly influence the appearance of a building facade and its relationship to the street.

It is the intent of these standards to influence designers to properly use these elements to enhance the connectivity of the building language throughout the corridor as well as provide continuous opportunity for shade.

Standard

For all non-marine industrial zoned properties awnings, overhangs and arcades shall be continuous in appearance along individual buildings.

This can be accomplished applying the following criteria:

- Awnings, overhangs and arcades must match the architectural style of the building.
- Arcade width shall be a minimum of 15'. Proportions shall be taller than wide.
- Awnings and overhangs may encroach into the street up to 8' for zero lot line buildings, but must be set back from the edge of travel lane by 3'.
- Awnings and overhangs can be used for commercial storefronts, but they must also be used for functionality (providing shade/rain protection).
- Awnings and overhangs shall not be used as a replacement for signage.
- Awnings may have side panels, but no panels to enclose the underside of the awning.

- The awning profile must be angled or curved in section.
- All awnings and overhangs on a single building shall be the same material and color. Minor variations in size are acceptable to accommodate building openings.
- The vertical flap of the first floor awning or overhang shall be a minimum 10' in height.
- Awnings shall not be internally illuminated.
- Lettering may be used on the vertical flap of the awning or overhang only, and cover a maximum of 50% of the vertical flap.



The cafe seating shown above provides obstruction-free right-of-way pedestrian passage through the seating area.

- Awnings shall be extended horizontally from the building and shall be supported by metal rods, metal wire, cables, or metal brackets.
- Awnings shall not be used above the base of the first floor of the building.
- Internal structure of the awnings shall be metal.
- Awning material shall be matte; non glossy.



Simple awnings can provide shade for pedestrians to comfortably window shop & interact with the buildings interior.

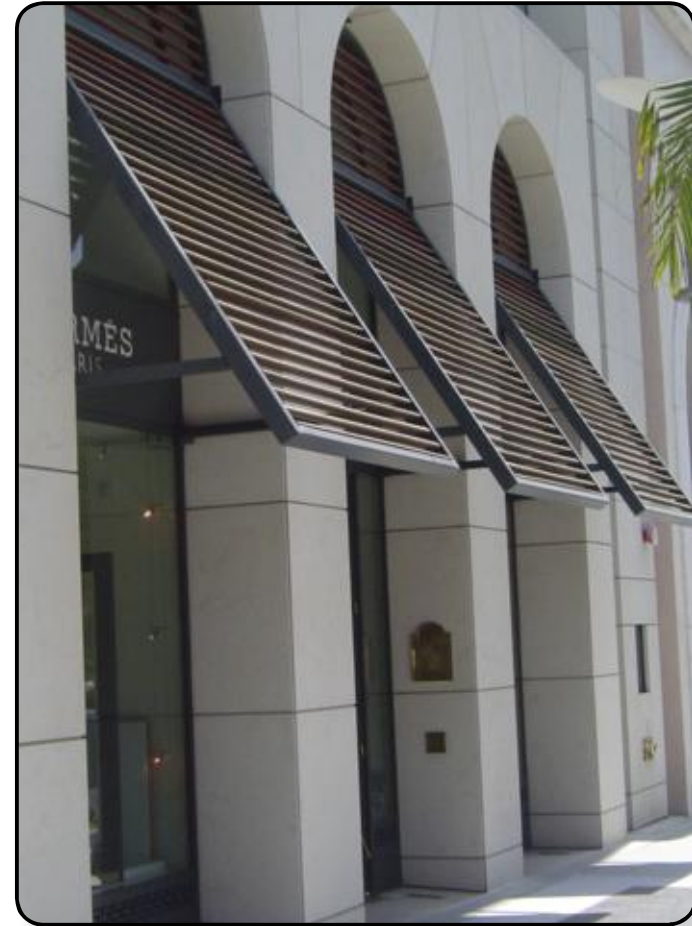

This decorative awning works well to accentuate the buildings character.

ZONE 2 – ARCHITECTURAL FACADE TREATMENTS

Riverside Awnings, Overhangs and Arcades

Background/Intent

Having a consistent appearance to an area can be important in attracting customers and “window shoppers.” By not allowing certain types of awnings or canopies, the overall effect is that of a cohesive and aesthetically pleasing area.

Standard

For all non-marine industrial zoned properties, awnings, overhangs or arcades shall be used to enhance building facades and provide shade.

This can be accomplished applying the following criteria:

- Arcade clear width (excluding columns) shall be a minimum of 8'. Proportions shall be taller than wide.
- Minimum span between columns shall be 8' from edge of column to edge of column.
- Awnings and overhangs may encroach into the riverside setback up to 5', but may not encroach into riverside riverwalk. Architecturally significant elements such as cantilevers may encroach up to 25' into the setback, but may not encroach into the riverwalk.
- Awnings and overhangs can be used for commercial storefronts, but they must also be used for functionality (for providing shade, rain protection).
- Awnings and overhangs shall not be used as a replacement for signage.
- Awnings may have side panels, but no panels to enclose the underside of the awning.
- The awning profile must be angular or curved in section.
- All awnings and/or overhangs on a single building shall be the

same material and color. Minor variations in size are acceptable to accommodate building openings.

- The vertical flap of the first floor awning or overhang shall be at a maximum height of 10'.
- Awnings shall not be internally illuminated.
- Lettering may be used on the vertical flap of the awning or overhang only, and cover a maximum of 50% of the vertical flap.
- Awnings shall be extended horizontally from the building and shall be supported by metal rods, metal wire, cables, or metal brackets.
- Awnings shall not be used above the first floor of the building.
- Internal structure of the awnings shall be metal.
- Awning material shall be matte; non glossy.



The canopies shown above provide shade for the user and complement the building's architecture.

ZONE 2 – ARCHITECTURAL FACADE TREATMENTS

Lighting

Background/Intent

Appropriately used, lighting makes a tremendous impact to a facade. There are many uses for lighting: decorative, focal point, safety, and signage. It is the intent of these standards to allow for ample variation in the lighting methods and products used while accentuating the facade to provide a welcoming atmosphere.

Standard

Building facades and exterior private property areas shall be appropriately lit to enhance the visual quality and provide for added safety at night.

This can be accomplished applying the following criteria:

- All lighting shall be metal halide or other white light sources (refer to UES standards for proper footcandle requirements for various spaces).
- All lighting elements, including site lighting, shall be of the same palette and shall relate in design to the building.
- Storefront lighting shall illuminate all signs, entrances, displays and interiors at appropriate levels.
- Channel lettering signs may be backlit with incandescent spotlights or fluorescent or neon tubing.
- Incandescent spotlights may be placed at intervals above channel lettering signs.



Typical signage spot lighting.



Above is an example of backlit channel-set signage.

ZONE 2 – ARCHITECTURAL FACADE TREATMENTS

Signage

Background/Intent

Signage creates an image of a business and corridor before a customer or client enters the store. A hodge podge of signage types along a single building creates a very messy and disconnected image. A standardized signage type creates a unified, clean image which promotes an inviting and secure environment to the customer.

The intent of this document is to establish clear standards that regulate signage in order to create a more cohesive and distinct storefront appearance along the Miami River corridor.

Standard

All building signage shall conform to the standards set forth herein and the City of Miami sign ordinance.

This can be accomplished applying the following criteria:

- Maps and kiosks are encouraged as part of a wayfinding program.
- Channel lettering shall be used instead of wall signage.
- All building signs shall be the same style and size.
- All storefront signs shall be the same style and size and shall be smaller than the building sign.
- Wall color and signage lettering shall be of contrasting colors and shall be a script or stylized font.
- Signs shall be located directly above the entrance of the store, above the awning, or in the frame of the storefront.
- 1.5 Square feet of signage for each linear foot of store front shall be permitted for total signage surface area.
- Projecting signs shall be mounted to fixed, metal arms.

- 40 Square feet of area is permitted for signs projecting 4 feet from the building. 60 Square feet are allowed for signs projecting 2 or 3 feet from the building.
- Incandescent spotlights shall be used to light projecting signs.
- Fluorescent tubes or neon are permitted to backlight channel lettering.

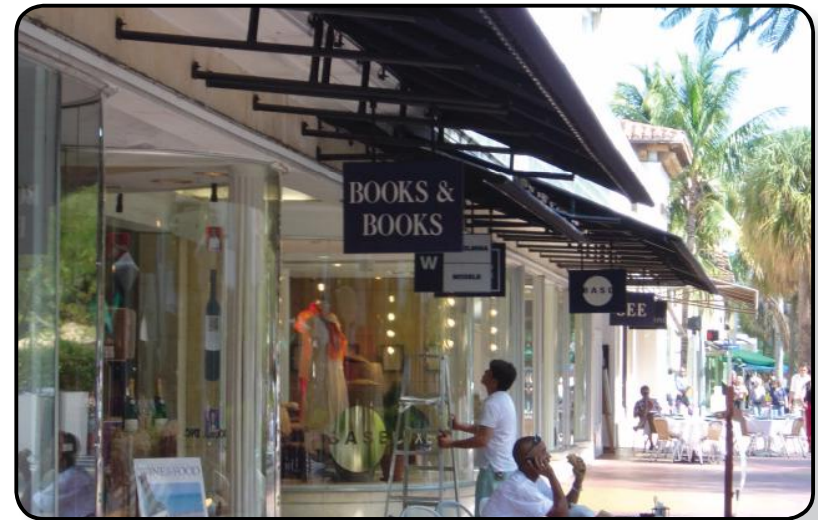

By maximizing frontage, businesses will have more interaction with the street and with pedestrians.

ZONE 2 – ARCHITECTURAL FACADE TREATMENTS

Public Accessibility

Background/Intent

As identified in the Miami River Action Plan as a primary goal, improved access to the River is an important element for the future success of the Greenway and the Riverwalk. The primary intent is to create, where possible, opportunities for pedestrians to access the Riverfront and connecting it to the Greenway. Refer to Zone 4 – Connections standards.

Standard

For all non public and marine industrial properties, a public access connector at least 20 feet wide is encouraged for properties with 100 feet or more of river frontage.

This can be accomplished applying the following criteria:

- Encourage access by implementing a clear and attractive wayfinding/signage system.
- Provide sufficient lighting and openness along the connections to promote safety and security.
- Utilize common elements such as hardscape and lighting to enhance the connectivity.



Well-defined public access incorporates strong edges, lighting for security, planting, and an attractive hardscape design that serve to draw people to and from the Riverwalk to the Greenway.

ZONE 3 – RIVERWALK

ZONE 3 – RIVERWALK GUIDELINES

Background/Intent

The Riverwalk is a unique and outstanding amenity for the City of Miami. The potential to connect nearly 11 miles of riverfront to public streets in a greenway network will add a higher level of urban quality of life to the city. This section focuses on establishing standards to regulate and unify the design of the riverwalk as it is pieced together one property at a time. It is the intent of these standards to establish the continuation of the Riverwalk adjacent to non marine industrial properties only. For those properties that are industrially zoned, the Riverwalk should be connected to the streetscape and become part of the Miami River Greenway corridor.

Included in this section are the following standards:

- Material Transitions
- Hardscape
- Seating
- Lighting
- Signage
- Landscape Material

Key Map

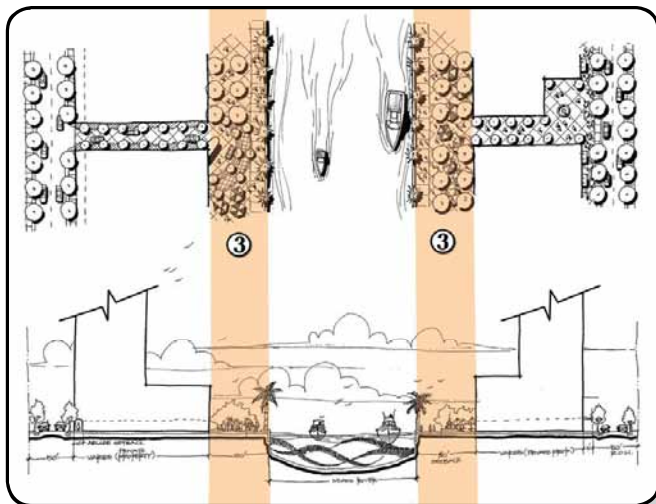

- In accordance with the Miami River Greenway action plans, the riverwalk shall include the following zones:
 - a. Edgezone – A bulkhead or seawall shall be at a constant elevation and 18 to 24 inches wide at the top.
 - b. Safety Buffer Zone – Areas within 3 feet of water shall be denoted with rough textured surfaces, such as cobble or river rock.
 - c. Circulation Zone – Linear walkways to be a minimum 15 feet clear width.
 - d. Passive Zone – No less than 3 feet wide, may be elevated for short lengths, all benches must have back rests and emphasize direct views. Seating surfaces shall be Purple Heart, western red cedar or redwood. Trash receptacles, drinking fountains, canopies, etc, shall be confined to this zone.
 - e. Transition and Security Zone – Min. 3' wide buffer from adjacent private development. Security and landscape barriers shall not visually screen the river.

*Reference cross-section from city in appendix.



When properly developed Riverwalks can become a viable, active amenity for an urban area.

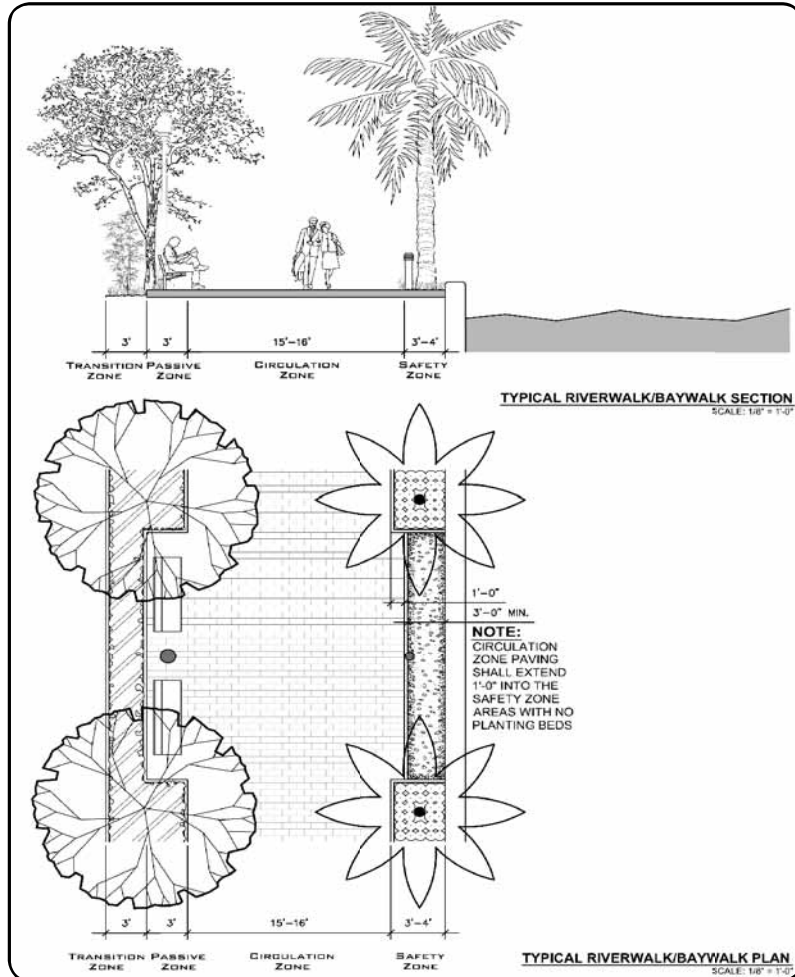

City cross section

The City of Miami has developed Waterfront Design Guidelines for Baywalks & Riverwalks. The section above illustrates a typical scenario showing the different components of the cross section from bulkhead to the transition area.

UTILIZING AREAS UNDERNEATH BRIDGES

Another important element to consider in developing a continuous and vibrant Riverfront is the design of the spaces underneath the existing bridges. These neglected spaces are missed as they lack all of the elements that make urban spaces user friendly: lighting, security, seating, and definable attractive edges.

Property owners that abut these spaces are encouraged to coordinate with the appropriate agency (usually FDOT or Miami Dade County) to develop potential joint agreements that would allow the property owner to create a usable space underneath the bridges thus enhancing the connectivity and quality of the entire river.

In cases where there is no existing space underneath a bridge for the riverwalk to continue through, alternative design options can include a cantilevered boardwalk over the river or a clear and accessible route over the bridge or beneath it.



The example above illustrates a cantilevered boardwalk extending over the river.

ZONE 3 – RIVERWALK GUIDELINES

Material Transitions

Background/Intent

It is important to maintain a sense of consistency for materials along the river. This can be accomplished by having transitional elements between abutting properties. For example landscape is one material that can be used to transition and make the passage along the riverwalk more integrated.

Standard

Along edges of a property, an area between 10 linear feet to 20 linear feet open to the sky shall be designated as a transition zone where materials shall gradually transition to conform to an adjacent property.

This can be accomplished by applying the following criteria:

- New developments shall incorporate into the required transition area within their properties, elements of the adjacent-existing development.
- In the case that two new developments are occurring simultaneously, it is the responsibility of both properties to:
 - a. Establish transition zones on both properties.
 - b. Coordinate the integration of the design elements.
- For properties abutting bridges, said properties are encouraged to design pedestrian friendly usable spaces underneath the bridges. This will involve proactive coordination with Miami-Dade County or FDOT.

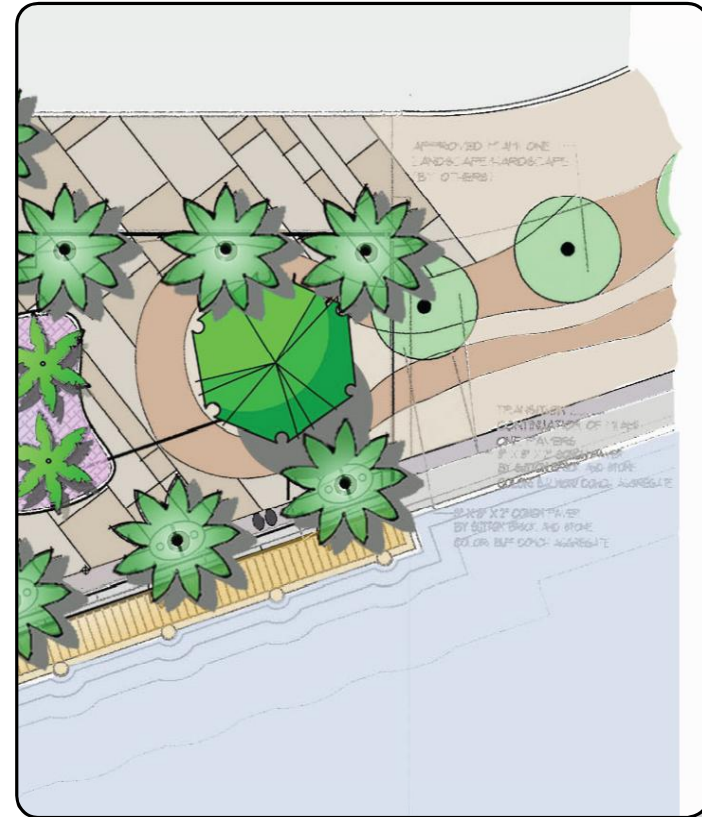

The rendering above illustrates the proposed landscape blending with hardscape and landscape elements from the adjacent site on the right.

ZONE 3 – RIVERWALK GUIDELINES

Hardscape

Background/Intent

The intent of these guidelines is to allow individual properties the freedom to express their design through hardscape. The focus of these guidelines rests primarily on establishing criteria for safety and continuity along the riverfront.

Standard

The connector shall be built of ADA approved walkable material. Said material surface shall be of a non-slippery texture.

This can be accomplished by applying the following criteria:

- Hardscape material shall conform to the transition zone requirement set forth in Zone 3 – Riverside Riverwalk.
- Hardscape material type, pattern and color should serve to compliment the building and other open space areas such as plazas and courtyards within the property.
- Hardscape surfaces of colored concrete shall have integral color, not surface color applications.



The above image shows colored concrete used along a sidewalk.



The image above shows pavers used along a riverwalk. All hardscape material shall conform to the transition zone requirements.

ZONE 3 – RIVERWALK GUIDELINES

Seating

Background/Intent

In order to encourage individual design while providing for desired elements that will help to invigorate the riverwalk, the focus on seating is geared towards establishing a minimum requirement for providing seating while not attempting to limit the possibilities in the types and designs.

Standard

Properties abutting the riverwalk shall provide seating opportunities along the entire length of the riverfront, frontage at a maximum interval of 50 feet on center. This could be delivered by staggering the seating along the riverwalk. A minimum clear width of 15 feet must be maintained at all times for pedestrian access. Cafe, restaurant, and retail seating does not count toward this requirement. Steps, if designed to accommodate seating proportions may count towards this requirement.

This can be accomplished by applying the following criteria:

- Seating should be made of durable, lasting materials that will withstand the harsh Southern Florida sun and rains.
- Seating should be placed as to maximize interaction between the property and the riverwalk.
- Seating should be fixed permanently to the riverwalk for safety concerns.
- If a property owner chooses not to do a custom design seating option, the typical greenway bench option should be utilized. Refer to Appendix 'C'.



The photo illustrates a good example of providing permanent seating all along the walkway in the form of a seating wall.



Typical Greenway bench – refer to furniture palette, Appendix C.

ZONE 3 – RIVERWALK GUIDELINES

Lighting

Background/Intent

As with other elements along the riverwalk, the intent for the lighting is to provide the individual property the freedom to express an individual vocabulary. These guidelines direct the lighting attention towards safety, security and efficiency.

Standard

For properties abutting the riverwalk, a consistent footcandle level of at least 1 footcandle must be established throughout. Properties shall only utilize metal halide lamps. Light spillage into adjacent properties and the river shall be avoided.

This can be accomplished by applying the following criteria:

- Refer to Appendix 'C' for the typical light pole.
- Lighting should relate in design with the overall design of the property and riverwalk.
- If the property owner wishes to utilize a standard pole; other than a custom pole, the typical greenway light pole shall be utilized.
- Properties may utilize overhead lights, lighted bollards, landscape up lighting and ground lighting to accent the design. All fixtures shall be metal halide.
- All light fixtures shall be weather resistant.
- Light fixtures and poles should be of matching colors.

- In accordance with the City of Miami Design Standards for Baywalks and riverwalks, the following shall apply:
 - a. At water's edge, 8 inch bollards shall occur at 20 feet on center.
 - b. Overhead lighting shall only occur in passive zones, 50 feet on center.
 - c. No colored lighting shall occur, except in private areas.
 - d. No vintage, stylized, or period design lighting shall be used.



Above: Typical Greenway bollard light.

Below: up lighting is used to accent the landscape and the building. In addition, this type of lighting can also be used for security purposes.

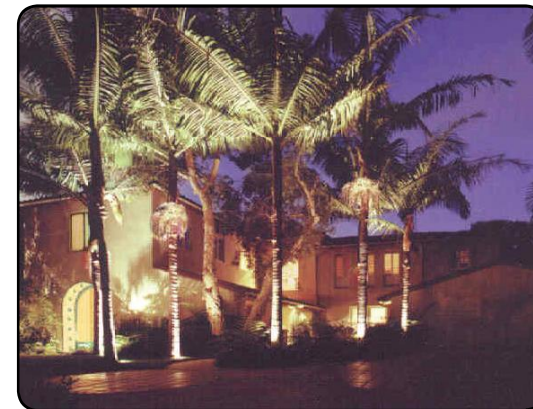

ZONE 3 – RIVERWALK GUIDELINES

Signage

Background/Intent

The way finding signage component along the Riverwalk will assist in unifying the design language along the length of the river, as well as provide important way finding information for users. The intent of these standards are to provide signage at necessary junctions of the Riverwalk to both enhance the sense of unity along the corridor, as well as to be an informative tool for users of the corridor.

Standard

All signage along the riverwalk shall conform to wayfinding signage standards as presented within this document.

This can be accomplished by applying the following criteria:

- All public access to and from the shall be marked with a directional sign. Such sign must read “Public Shore” and shall include a key map showing the relevant location along the river.
- Adjacent accessible development (i.e. Retail) signage shall conform to signage standards from Zone 1.
- Historic and/or environmental markers shall be located at appropriate areas along the riverwalk to ensure clear pedestrian interaction.
- Refer to Appendix D for additional way finding signage information and details.

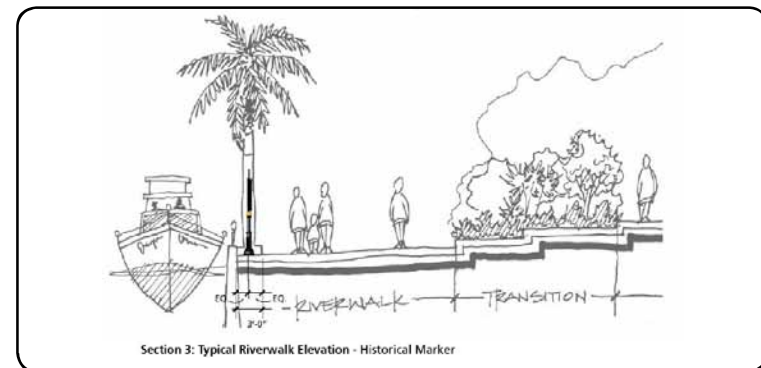
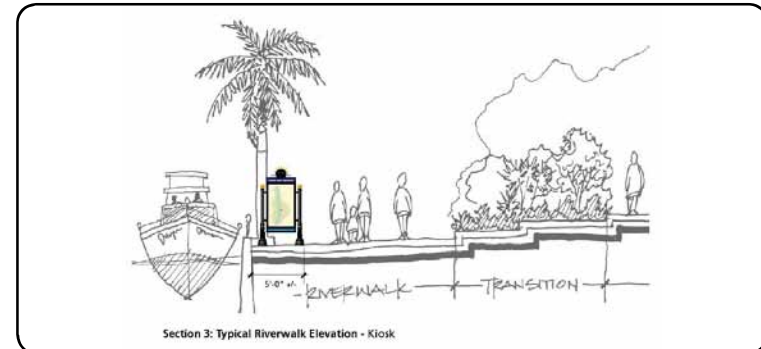
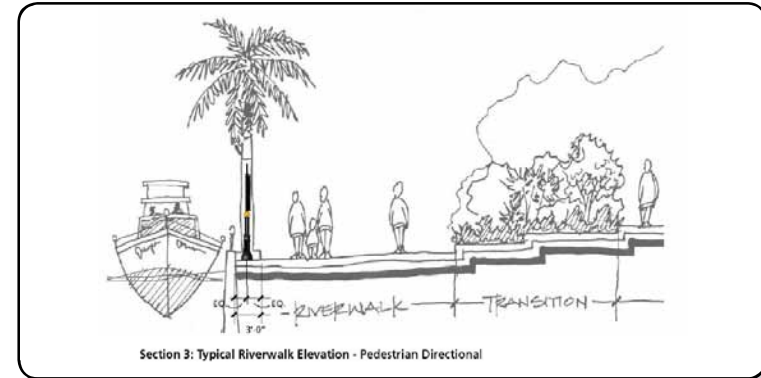

ZONE 3 – RIVERWALK GUIDELINES

Signage



Typical sign palette for Riverwalk

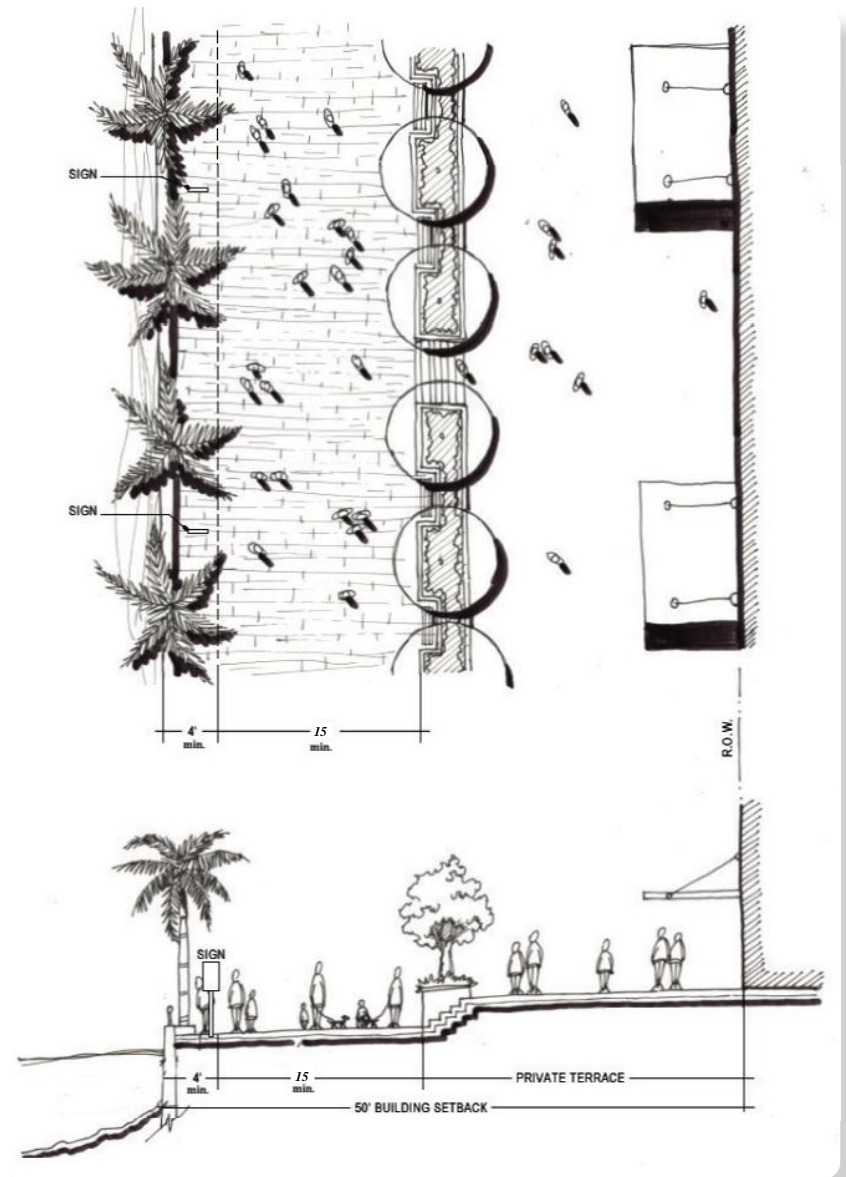

The graphic above illustrates the appropriate location for signage along a typical 50' cross section of the Riverwalk.

ZONE 3 – RIVERWALK GUIDELINES

Landscape Material

Background/Intent

Plant material is essential in hardscape areas to soften the design and bring much needed shape and diversity into an exposed area. These guidelines focus on establishing a plant palette that will flourish in the Southern Florida climate while providing the individual design with latitude to express their own unique designs.

Standard

Landscape material shall be incorporated along the frontage of properties within the riverfront. A row of trees or large palms shall be planted a maximum of 30 feet on center and no greater than 50 feet apart, along the entire length of the property frontage. The ratio of trees and palms shall be 1:1 where possible, unless deemed unfeasible due to site conditions. Minimum planting beds for trees and palms shall consist of 108 cubic feet of volume. Minimum planter depth shall be 3'. Root barrier shall be utilized for planters where canopy trees and large palms are utilized. A minimum of eight (8) shrubs or groundcover shall be planted around each tree or large palm. Potted plants shall not count towards tree requirements.

This can be accomplished by applying the following criteria:

- Refer to plant palette on Appendix A for allowed range of plant material.
- Utilize potted plants where helpful to compliment the landscape.
- Plant material should be properly irrigated to ensure survivability and an established healthy appearance. Native and xeric material is encouraged.
- Refer to City of Miami – Landscape Scope – for sizes and quality standards for plant material.



Planters are a good way to keep material contained and provide for ease of maintenance while adding to the aesthetic quality of the streetscape.

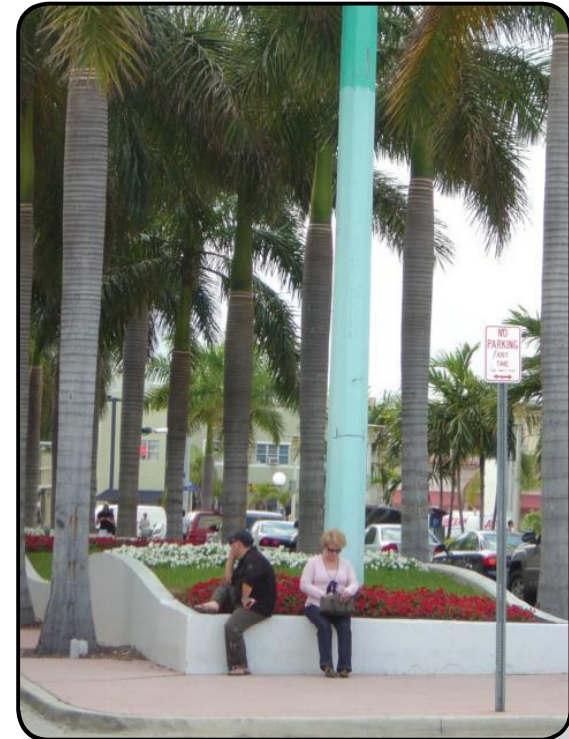

Linear palm planting with seating, forms a clearly defined edge.

ZONE 4 – CONNECTORS

ZONE 4 -CONNECTORS

Overall Background/Intent

One of the primary goals of all of the studies that have been prepared for the Miami River Corridor has been to provide public connections to and from the river. These connectors can come in many forms, such as plazas, parks and streets. This section focuses on developing standards to define an envelope upon which a variety of connectors may be developed appropriately to link the streets to the riverside riverwalk and vice versa. Connectors are encouraged for all non-industrial properties only.

Included in this section are the following standards:

- Edge Treatments
- Plazas/Pocket Parks
- Views
- Hardscape
- Seating
- Lighting
- Signage
- Landscape Material



This connector is successful in creating a clearly defined visual and physical link between the riverwalk and the adjacent street

Key Map

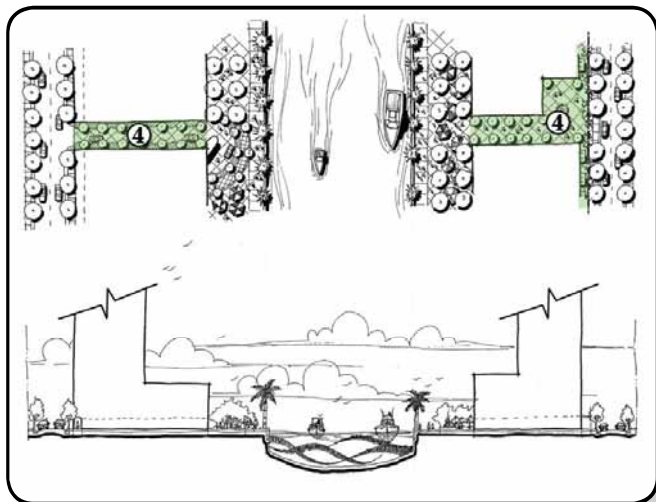

ZONE 4 – CONNECTORS

Edge Treatments

Background/Intent

The building's relationship to the connectors should contribute to a safe and active environment for gathering and walking. The same principles and standards utilized in Zone 2 – Private Property should be incorporated in the facades fronting the connector corridors.

Standard

Facades along the edges of connectors shall be as vibrant as possible to promote interaction and safety.

This can be accomplished by applying the following criteria:

- Place active uses along connectors such as ground floor residences and possible retail uses.
- Incorporate facade transparencies, proper scaling, and facade articulation to enhance the quality of the edge condition.
- Edges should not be dark and blend, but designed as to promote safe and willing passage.

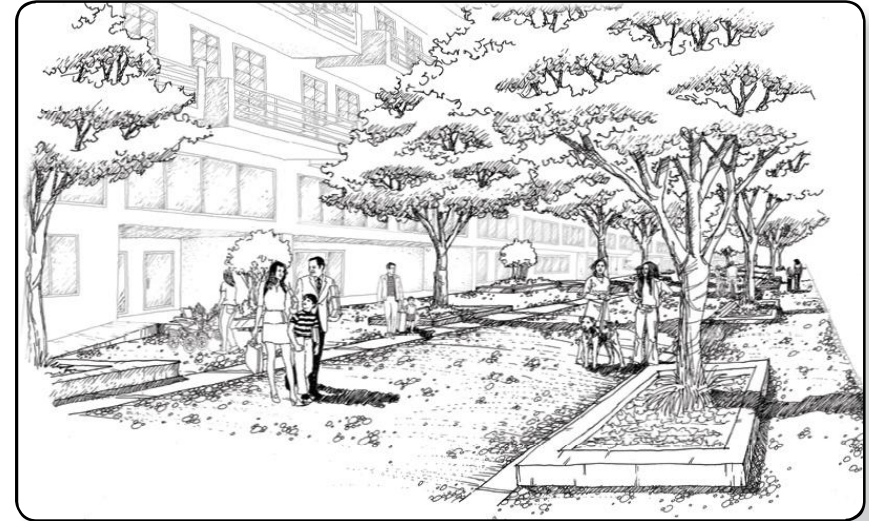

The residential balconies above face the corridor, and provide an interactive edge.



This image illustrates the use of art as a transparent edge, separating public and private use, while allowing visual interaction between the spaces.

ZONE 4 – CONNECTORS

Plazas/Pocket Parks

Background/Intent

Some of the best urban parks are small, intimate scale pocket parks and plazas that provide refuge from the urban environment with basic amenities. These spaces can be blended with the connectors to create a higher level connectivity. Opportunities for additional retail, residential frontage, and landscape may also be incorporated into these spaces to further enhance the quality and dynamic of the connector.

Standard

It is recommended that where possible, connectors to the riverwalk be designed as linear plazas or pocket parks.

This can be accomplished by applying the following criteria:

- Plazas and parks shall incorporate CPTED principles in their design to enhance the safety of the spaces (refer to CPTED guidelines – Appendix E).
- Plazas and parks shall incorporate signage which denotes “Public Access” at both ends. Refer to signage guidelines.
- Plazas and parks shall be designed to accommodate for a variety of passive uses including shaded seating, walking and gathering.
- Refer to landscape, hardscape, lighting, signage, and furniture standards for proper design considerations.

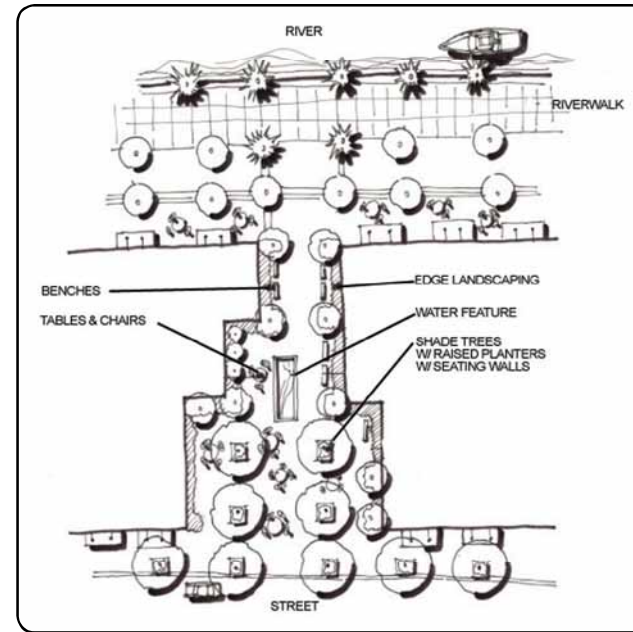

This proposed plaza scenario incorporates cafe seating in shaded areas, water features to enhance the quality of the space and landscape edges to define the boundaries while providing a clear and safe connector between the riverwalk to the street.



Greenacre Park, shown above is a great example of an active urban pocket park situated between buildings and open to the street.

ZONE 4 – CONNECTORS

Vehicular Access

Background/Intent

It is the intent of these standards that vehicular access be limited as part of the connectors for all non-industrial properties. The focus is intended to be for pedestrian connectivity, and while it is recognized that in certain properties, some vehicular use will need to be incorporated with the connector designing a space should still read as a pedestrian dominated area.

Standard

Connectors to the Riverwalk may incorporate vehicular access given that there is a minimum pedestrian sidewalk width on at least one side with a minimum width of 10'.

- No vehicular access shall be permitted within the required setback area from the River, for all properties other than those zoned marine industrial.
- Vehicular areas may include emergency vehicle access, drive courts and parking/service entrances.



Vehicular access is limited to outside the 50' setback. This allows for more pedestrian orientated uses and access such as an urban plaza, restaurant seating, etc.

ZONE 4 – CONNECTORS

Views

Background/Intent

Views to and from significant elements within a city is a powerful planning concept that aids in ‘linking’ a large urban area together with a logical pattern. Establishing meaningful views across and along the river corridor will be a significant asset to drawing people into the corridor and down the corridor. Through correct placement of the connectors, important elements on both sides of the river can be visually linked to the river, thus creating a greater sense of unity along the river corridor.

Standard

Views to the river and to the street shall be maximized when possible by placement of the connectors.

This can be accomplished by applying the following criteria:

- Where appropriate, align connectors to frame interesting views and elements along both the river and the abutting streets.
- Add elements such as public art to create interesting views.

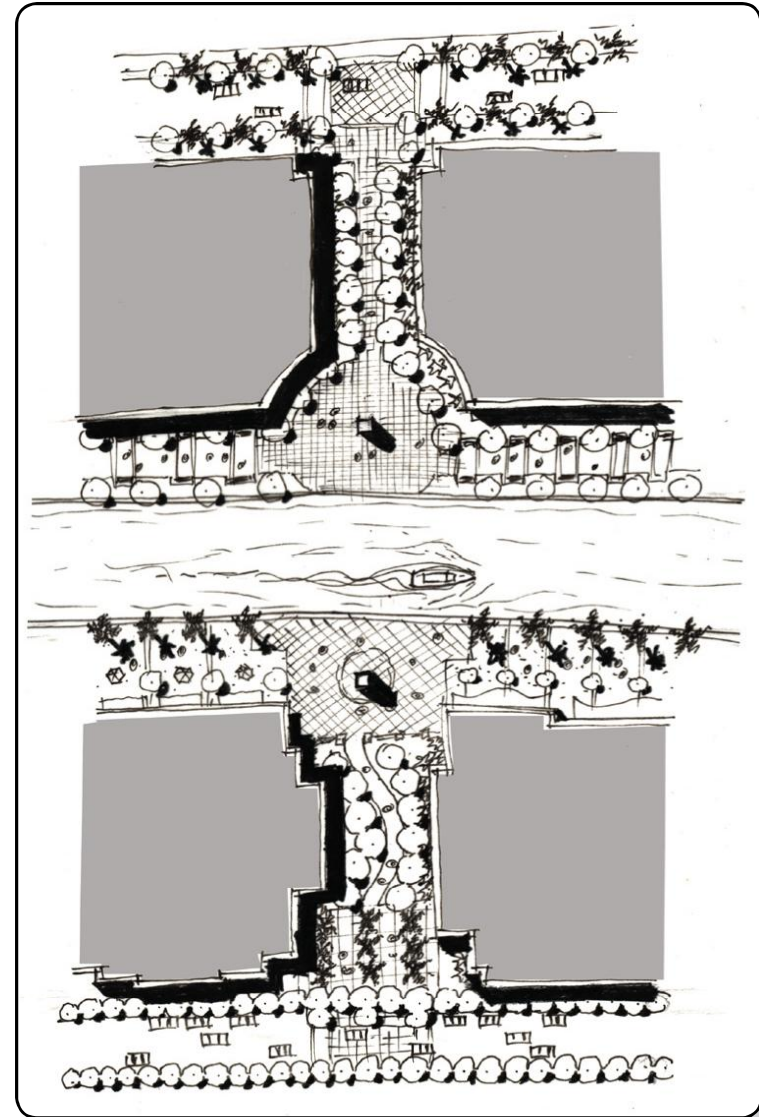

In order to connect elements of the city on both sides of the river, connector corridors should be aligned with points of interest.

ZONE 4 – CONNECTORS

Hardscape

Background/Intent

The intent of these guidelines is to allow individual properties the freedom to express their design through elements such as hardscape. The focus of these guidelines rests primarily on establishing criteria for safety and continuity along the riverfront.

Standard

The connector shall be built of ADA approved walkable material. Said material surface shall be of a non-slippery texture.

This can be accomplished by applying the following criteria:

- Hardscape material shall conform to the transition zone requirement set forth in Zone 3 – Riverwalk.
- Hardscape material type, pattern and color should serve to compliment the building and other open space areas such as plazas and courtyards within the property.
- Hardscape surfaces of colored concrete shall have integral color, not surface color applications.



The above image shows colored concrete used along a sidewalk.



The image above shows pavers used along a riverwalk. All hardscape material shall conform to the transition zone requirements.

ZONE 4 – CONNECTORS

Seating

Background/Intent

In order to provide multiple seating opportunities while allowing for unique and individual design, the focus of seating is to establish a minimum standard rather than regulate design.

Standard

Connectors shall incorporate seating along the entire length of the connector at a maximum interval of 50 feet on center. This could be met by providing benches, seat walls, planter walls and moveable furniture. A minimum clear width of 10 feet must be maintained at all times for pedestrian access. Cafe, restaurant, and retail seating not open to the general public shall not count toward this requirement.

This can be accomplished by applying the following criteria:

- Seating should be made of durable, lasting materials that will withstand the harsh South Florida sun and rains.
- Seating should be placed to maximize interaction between the property and the connector.
- If a property owner chooses not to do a custom design seating option, the typical greenway bench should be utilized. Refer to Appendix C.



Typical Greenway bench

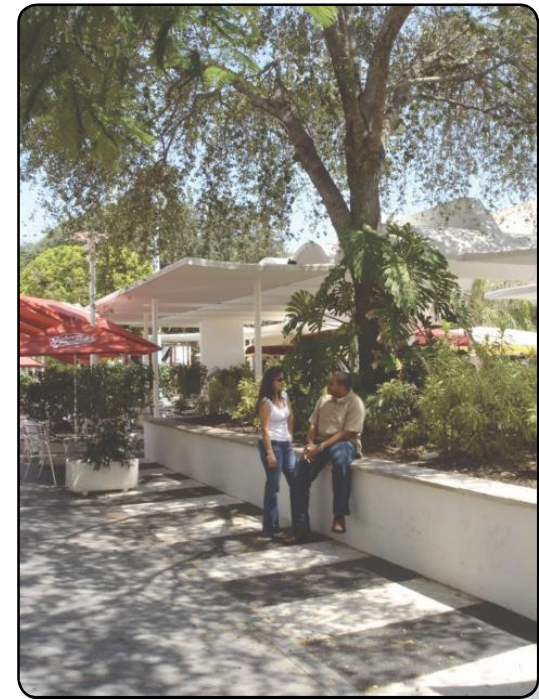

Example of a seatwall with ample shade provided in the background.

ZONE 4 – CONNECTORS

Lighting

Background/Intent

As with other elements for the connectors, the intent for the lighting is to provide a safe and usable environment. To properly light these areas, a variety of lighting sources should be utilized.

Standard

All lighting along connectors shall have a consistent footcandle level of at least 1. Properties shall only utilize metal halide lamps. Light spillage into adjacent properties and the river shall be avoided.

This can be accomplished by applying the following criteria:

- Lighting should blend in with the overall design of the property and its adjacent riverwalk.
- If the property owner wishes to utilize a standard pole; other than a custom pole, the typical greenway light pole shall be utilized.
- Properties may utilize overhead lights, lighted bollards, landscape up lighting and ground lighting to accent the design. All fixtures shall be metal halide.
- All light fixtures shall be made to be weather resistant.
- Light fixtures and poles should be of matching colors.



Typical Greenway bollard light.



Example of contemporary light pole.

ZONE 4 – CONNECTORS

Signage

Background/Intent

The wayfinding element of these standards should incorporate location markers, clearly indicating public access to and from the river.

Standard

Wayfinding markers stating “Public Access” shall be placed at each end of the connector.

This can be accomplished applying the following criteria:

- Maps and kiosks are required as part of a wayfinding program where appropriate.
- Refer to Appendix D for proper way finding signage design.



Typical wayfinding elements



Typical Kiosk

ZONE 4 – CONNECTORS

Landscape Material

Background/Intent

Plant material is essential in hardscape areas to soften the design and bring much needed shape and diversity into an exposed area. These guidelines focus on establishing a plant palette that will flourish in the South Florida climate while providing the individual design with latitude to express their own unique designs.

Standard

Landscape material shall be incorporated along the connectors. All blank facades shall be buffered by a minimum 3' wide continuous landscape buffer with a minimum height of 6'. Shade trees shall be placed along the length of the connector at a minimum average spacing of 30' on center. Minimum planting beds for trees and palms shall consist of 108 cubic feet of volume. Minimum planter depth shall be 3'. Root barrier shall be utilized for planters where canopy trees and large palms are utilized. A minimum of eight (8) shrubs or groundcover shall be planted around each tree or large palm. Potted plants shall not count towards tree requirements.

This can be accomplished by applying the following criteria:

- Refer to plant palette in Appendix A for allowed range of plant material.
- Utilize potted plants where helpful to compliment the landscape.
- Plant material should be properly irrigated to ensure survivability and an established healthy appearance. Native and xeric material is encouraged.
- Refer to City of Miami – Landscape Scope – for sizes and quality standards for plant material.

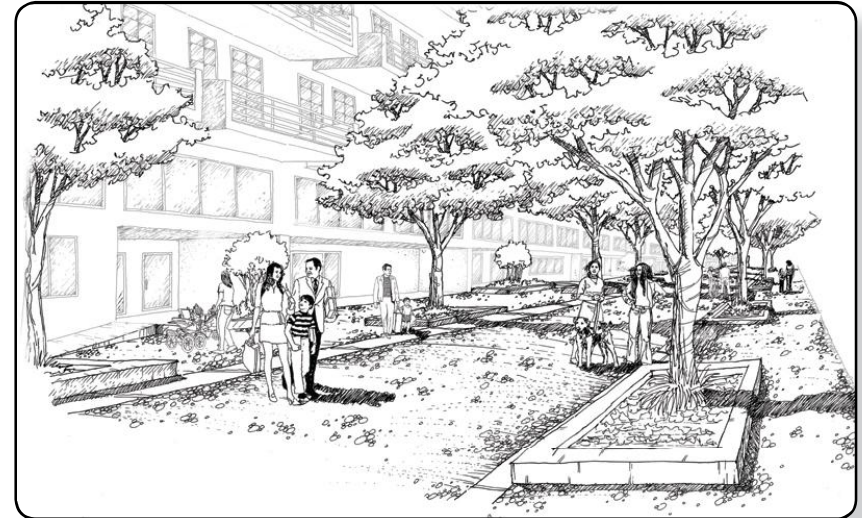

The connector shown above incorporates shade trees to provide a near-continuous canopy along the length of the connector.

LOWER RIVER

LOWER RIVER

Introduction

Overall Background/Intent

The Lower River section of this project extends from the mouth of the River at Biscayne Bay to 5th Street Bridge. It includes the Northern portion of Brickell Key, part of the Central Business District, Brickell, the Southern portion of Overtown, and East Little Havana neighborhoods.

Also included in this portion of the River is the Miami Circle Historic Site, Brickell Area River, Fort Dallas Park, Convention Center, Central Business District, Miami Government Center, Miami Riverside Administration Center, and portions of the existing riverwalk.

This section of the River is primarily dominated by high density commercial and residential development and is currently undergoing very rapid growth and redevelopment.

A tremendous amount of redevelopment and infill activity is currently present throughout this area. Condominium towers, lofts, multi-use office/commercial buildings are steadily rising on both sides of the river. As this area continues to grow and becomes a more vibrant and dense urban environment, it is critical that an enforceable set of standards are present to regulate the overall quality and appropriateness of the various improvements, both public and private.

It is the intent of these standards to develop a framework for the various urban elements that will shape the physical character for the Lower River.

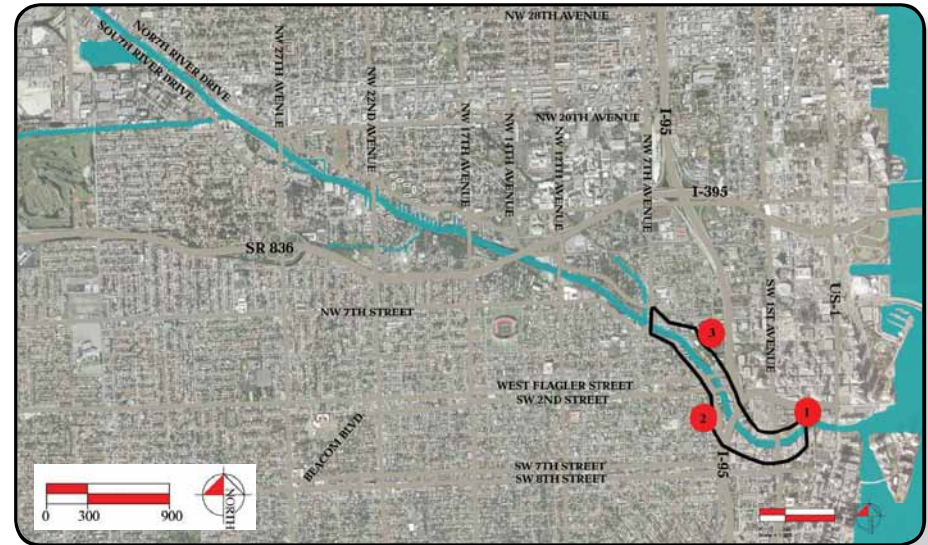

Key Map – Lower River Delineated in Black

Legend

1. Ft. Dallas/Miami Riverwalk
2. Jose Marti Park
3. Lummus Park

OVERALL PLAN AND SECTION

Introduction

The overall plan and section shown on the following page establishes the general physical criteria for the various components within each area of the River, including: Right-of-Way, Private Property, Riverwalk, Connectors, and the River itself.

The purpose of the overall plan and section is to give the user a comprehensive understanding of the desired character of each subarea. It is not intended to represent the only possible scenario. The proceeding section will focus on each individual component of the overall cross-section and plan, and develop specific design standards to guide future development, both public and private, along the Miami River Corridor.

MIAMI RIVER *Greenway Regulatory Design Standards*

LOWER RIVER – OVERALL PLAN AND SECTION

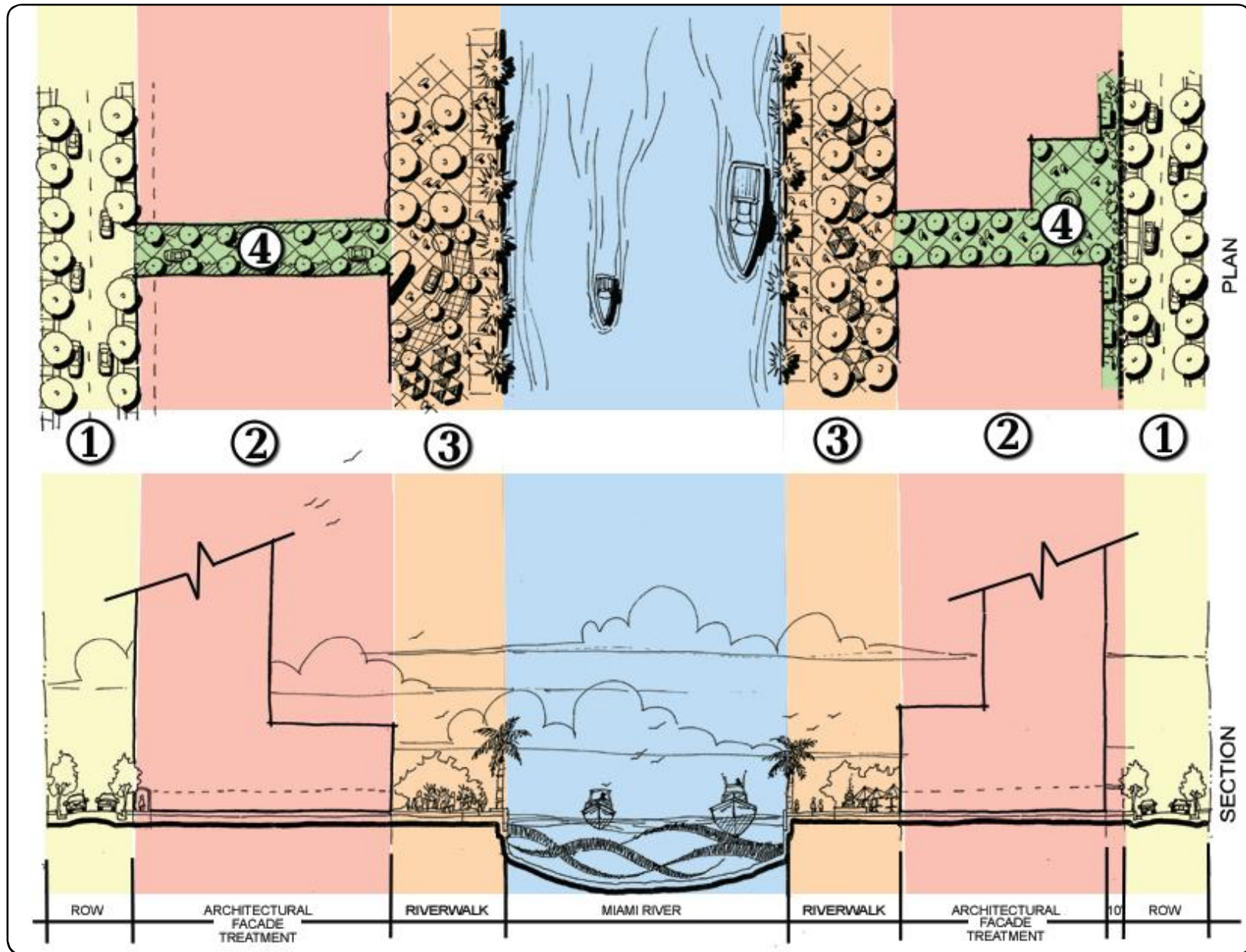

LOWER RIVER SECTION OUTLINE

To User:

This page contains a 'cheat sheet' for guiding the user through this chapter of the workbook. Each zone has a list of design elements that is included within that particular zone. Each zone is also color coded. The color is shown on the edges of the pages that belong to that zone.

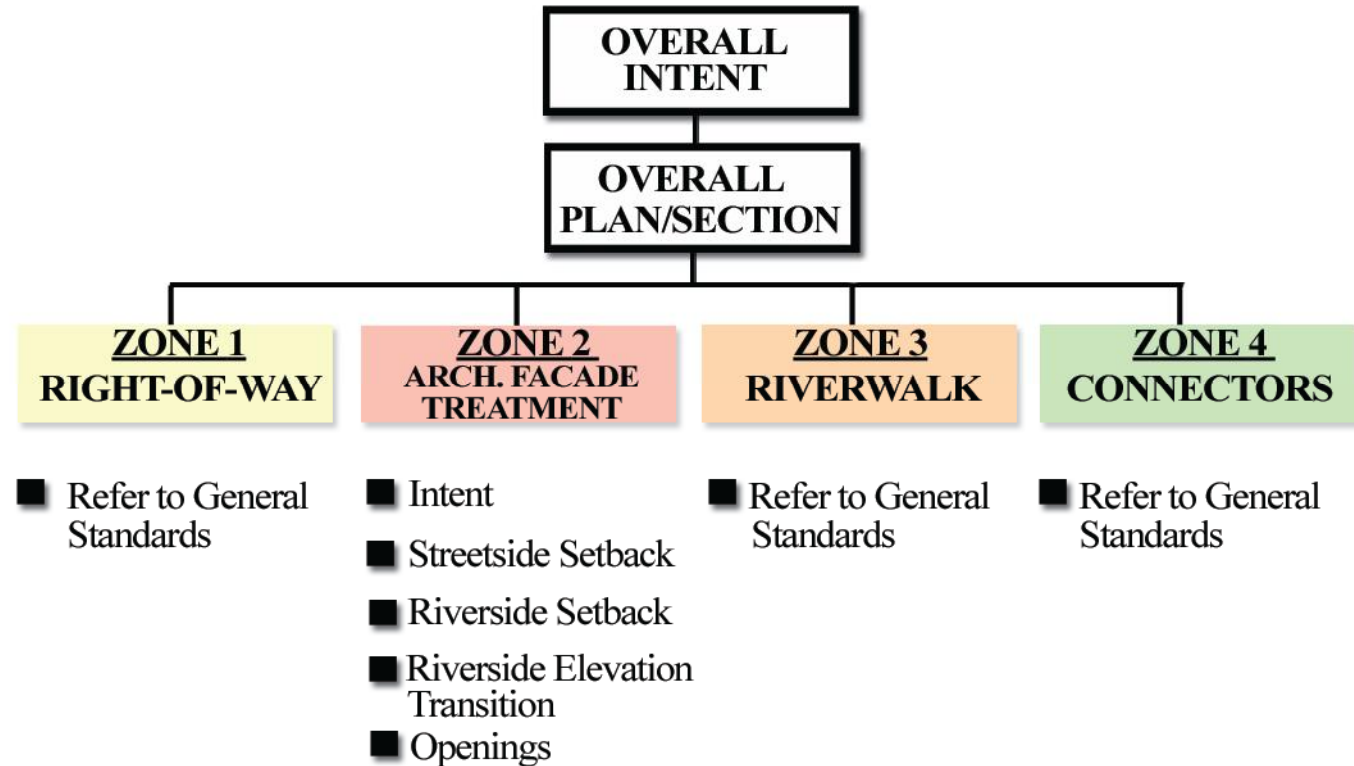

**ZONE 1 – STREET RIGHT-OF-WAY
REFER TO GENERAL STANDARDS**

ZONE 2 – ARCHITECTURAL FACADE TREATMENTS

ZONE 2 – ARCHITECTURAL FACADE TREATMENTS

Overall Background/Intent

The private property development along the Miami River should relate to the public realm in scale and character in order for the corridor to achieve its maximum potential for urban quality. The following section focuses on developing standards for the private properties abutting the right-of-ways of the Miami River corridor.

Included in this section are the following standards:

- Streetside Setback
- Riverside Setback
- Streetside Frontage
- Riverside Elevation Transition
- Openings

The standards set forth in this document work to enhance the physical appearance of the architecture along the Miami River Greenway corridor, and assist in creating a better relationship between the riverwalk and the buildings.

Key Map

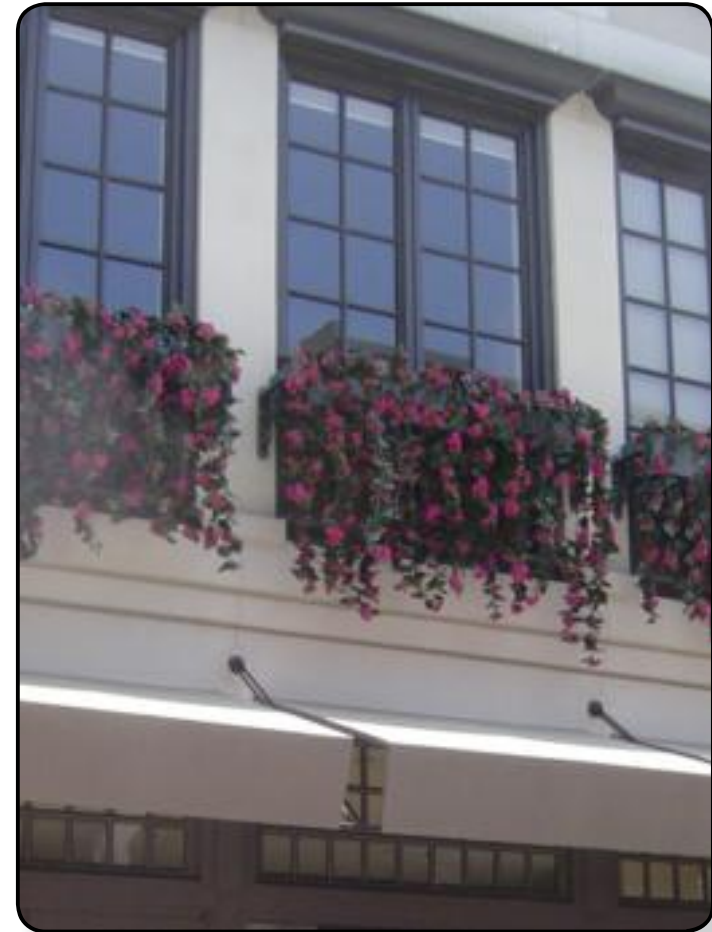
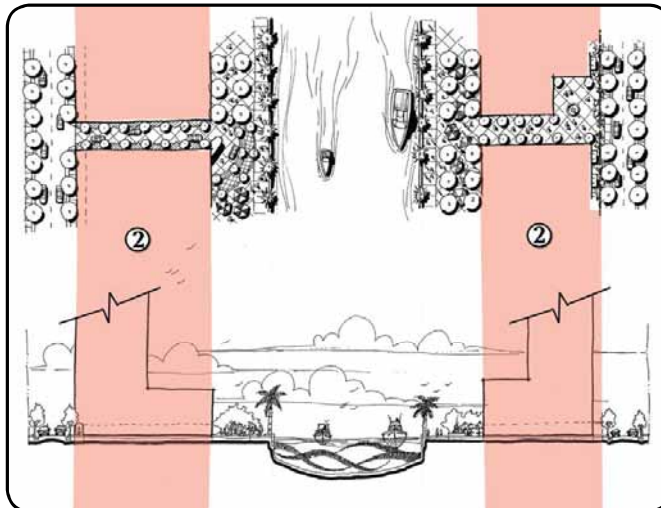

Standardized architectural facade treatments will assist in creating a cohesive look for the multitude of private sector development along the river.

ZONE 2 – ARCHITECTURAL FACADE TREATMENTS

Streetside Setback

Background/Intent

Front setbacks offer a great opportunity for urban amenities. This can include arcades, cafe seating, landscape or additional sidewalk width.

The intent of this standard is to provide a consistent setback while allowing for some variation to promote physical diversity in the corridor.

Standard

The setback shall be 10' from the right-of-way with an allowable 8' encroachment for awnings or canopies. If an arcade is used, the setback is 0' with an allowable encroachment maximum 3' from edge of curb into the right-of-way for awnings or canopies. Arcades shall be 15' in width.

This can be accomplished applying the following criteria:

- Setback areas are encouraged to include cafe seating if the abutting business suits the need.
- Paving materials shall either match the public side walk or be of a comparable material and color.
- If the adjacent building use requires a landscape buffer (i.e. blank wall), such area may be utilized for appropriate landscaping.
- Store owners may utilize potted plants within the setback area to delineate seating areas.

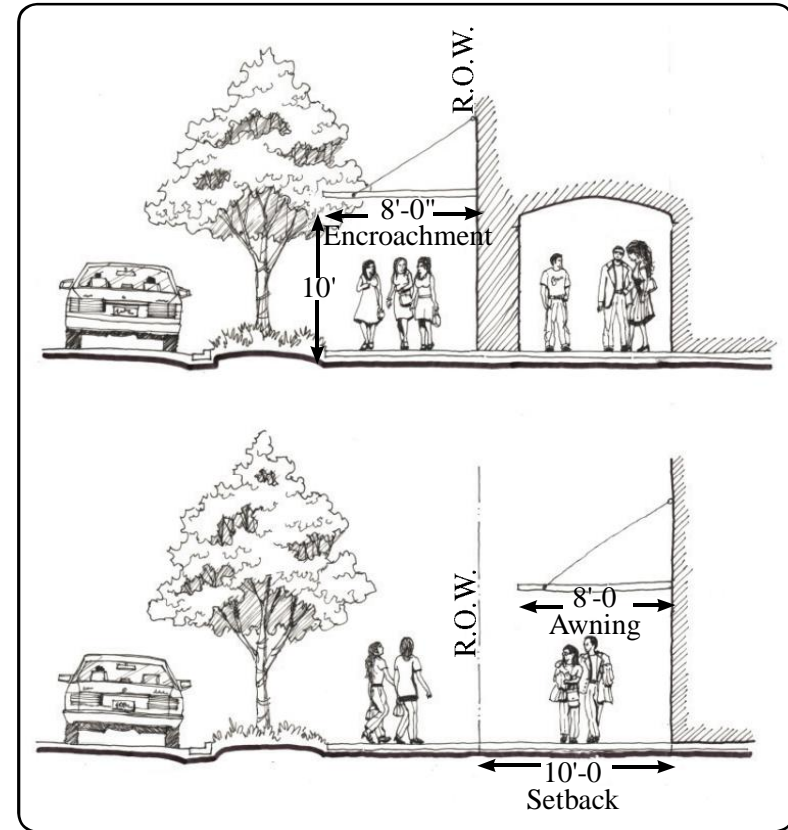

Streetside setback areas shown above

ZONE 2 – ARCHITECTURAL FACADE TREATMENTS

Riverside Setback

Background/Intent

In order to create active and meaningful spaces along the riverwalk, buildings shall be set back appropriately, and the setback area should incorporate a variety of uses. This can include cafes, plazas/parks, walkways and seating areas. In addition, the design of these areas is critical to their success (Refer to Zone 3 – Riverside Riverwalk Standards for additional information).

Standard

Waterfront Setbacks shall be a minimum of 50 feet provided along any waterfront, except where the depth of the Lot is less than 200 feet the Setback shall be a minimum of 25% of the Lot depth; and except for Single & Duplex Residential and Non-Marine Related Industrial uses, where a minimum Setback of 20 feet shall be provided, except where the depth of the Lot is less than 80 feet the Setback shall be a minimum of 25% of the Lot depth.

This can be accomplished applying the following criteria:

- Setback shall be spaces consisting of a variety of uses, as mentioned above.
- Materials shall either match the public sidewalk or be of a comparable material and color.
- If the adjacent building use requires a landscape buffer (i.e. blank wall), such area may be utilized for appropriate and tasteful landscaping.
- Store owners may utilize potted plants within the setback area to delineate seating areas.

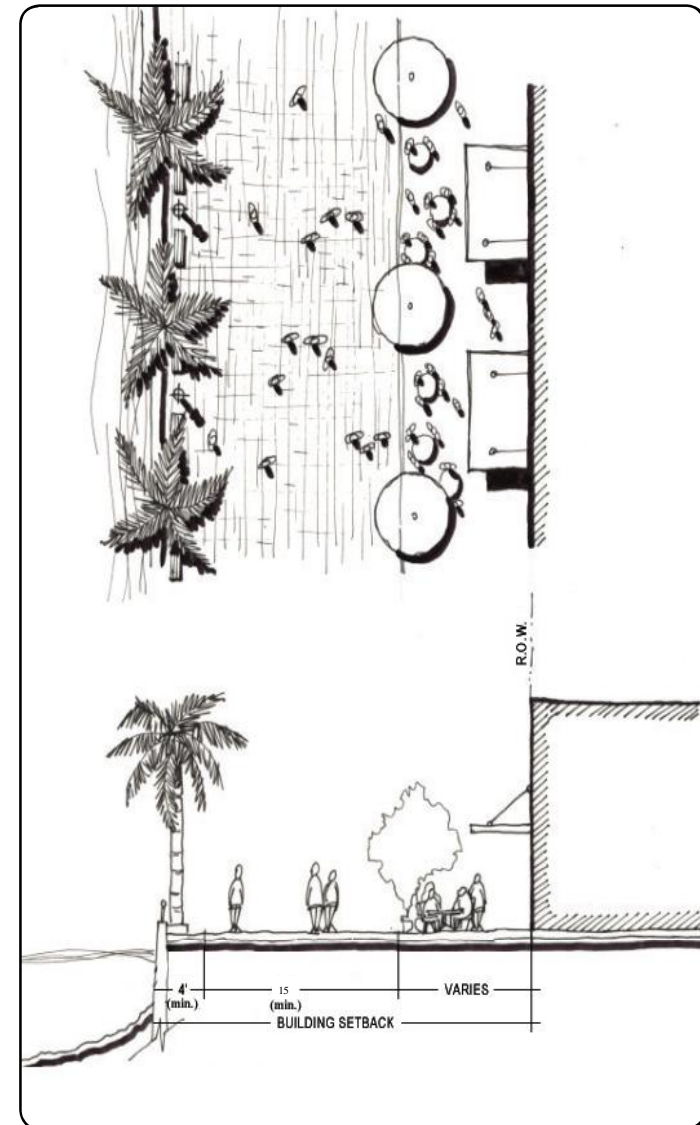

Typical Riverside Setback

ZONE 2 – ARCHITECTURAL FACADE TREATMENTS

Riverside Elevation Transition

Background/Intent

Buildings shall be more accessible, not only to adhere to ADA codes, but to encourage pedestrian flow and connectivity to and from the street. Designers should strive to create gradual transitions from the street to the entryway of the buildings that respond to flood zone requirements.

Standard

Elevation changes shall be addressed by gradual increments where possible.

This can be accomplished by applying the following criteria:

- The accessible route into the building should not detract from the primary entrance.
- The ramp or other feature shall blend with the architecture in color and in style.

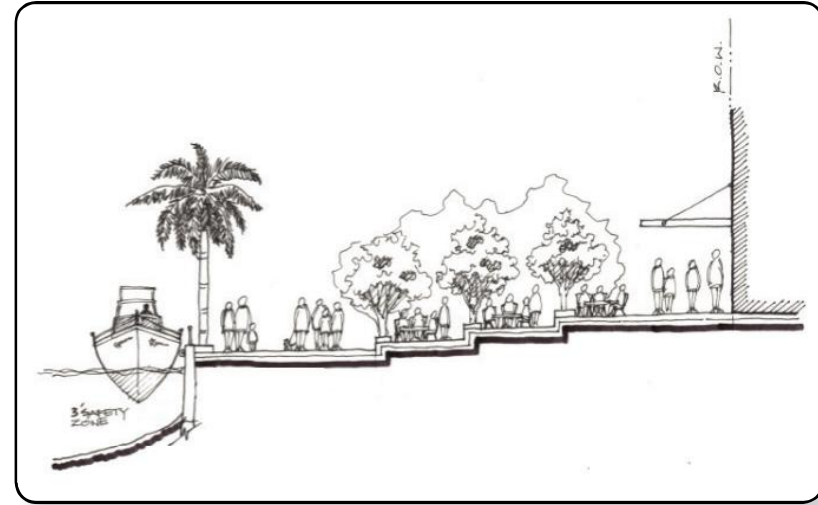

This scenario treats an elevation change gradually, allowing for an active use, such as cafe seating, to be accommodated along the transition.

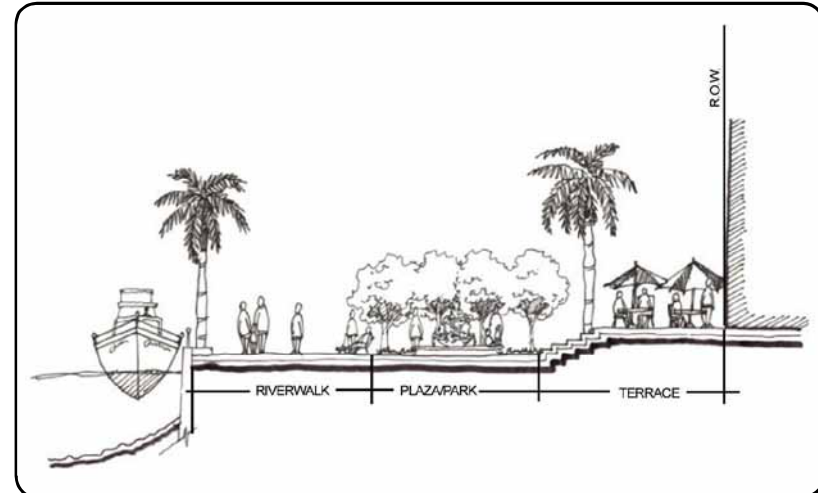

In this scenario, the grade transition is placed closer to the building, allowing for a larger passive area adjacent to the riverwalk.

ZONE 2 – ARCHITECTURAL FACADE TREATMENTS

Openings

Background/Intent

As with entrances, the openings along a facade should differentiate these focal points from the rest of the building. This creates interest in the architecture and encourages use along the corridor.

Standard

Facade openings shall be articulated to separate the plane of the building facade and create visual interest.

This can be accomplished applying the following criteria:

- Refer to transparency guideline for clear facade requirements.
- On masonry buildings, the lintel shall always be flush with the wall, while the sills shall project from the face of the building a minimum of one-half inch from the wall.
- Trim around windows and doors shall follow the basic construction techniques for the materials used in the building being served.
- The window heads and lintel of stucco finish buildings shall be made of pre-cast concrete, have a similar stucco finish, or be of cut and dressed stone.
- The window sills of stucco finish buildings shall be made of pre-cast concrete, have a similar stucco finish, or be of cut and dressed stone.



Highlighted entryway feature along the facade.



Window openings become an architectural feature for this facade.

**ZONE 3 – RIVERWALK
REFER TO GENERAL STANDARDS**

**ZONE 4 – CONNECTORS
REFER TO GENERAL STANDARDS**

MIDDLE RIVER

MIDDLE RIVER

Overall Background/Intent

The middle river section of the Miami River extends from NW 7th Avenue to NW 27th Avenue. This section includes the Civic Center as well as the Spring Garden, Durham Park, Lawrence and Grove Park neighborhoods.

This section of the river is generally characterized as a transition zone between the high density lower river and the industrially oriented upper river.

These standards strive to establish an identity for the middle river that compliments its dynamic make-up, respecting both the residential component, but also providing for continued river related industrial and commercial business to thrive.



Key Map – Middle River Delineated in Black

Park Locations

- 4. E. G. Sewell Park
- 5. Grove Park

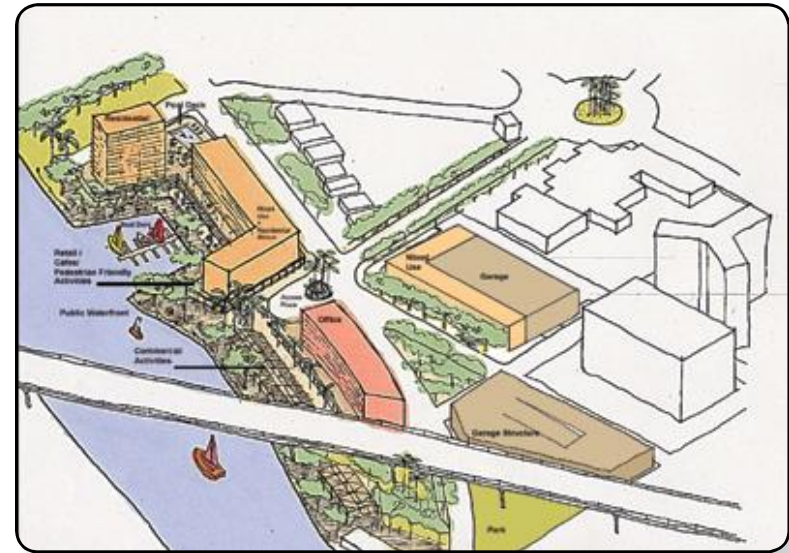

The Middle River offers tremendous opportunities for mixed-use developments, such as this yacht repair and mooring facility along the waterfront with a mid-rise community along the street-side. Refer to the Miami River Corridor Urban Infill Plan for further information.

OVERALL PLAN AND SECTION

Introduction

The overall plan and section shown on the following page establishes the general physical criteria for the various components within each area of the River, including: Right-of-Way, Private Property, Riverwalk, Connectors, and the River itself.

The purpose of the overall plan and section is to give the user a comprehensive understanding of the desired character of each subarea. It is not intended to represent the only possible scenario. The proceeding section will focus on each individual component of the overall cross-section and plan, and develop specific design standards to guide future development, both public and private, along the Miami River Corridor.

MIDDLE RIVER – OVERALL PLAN AND SECTION

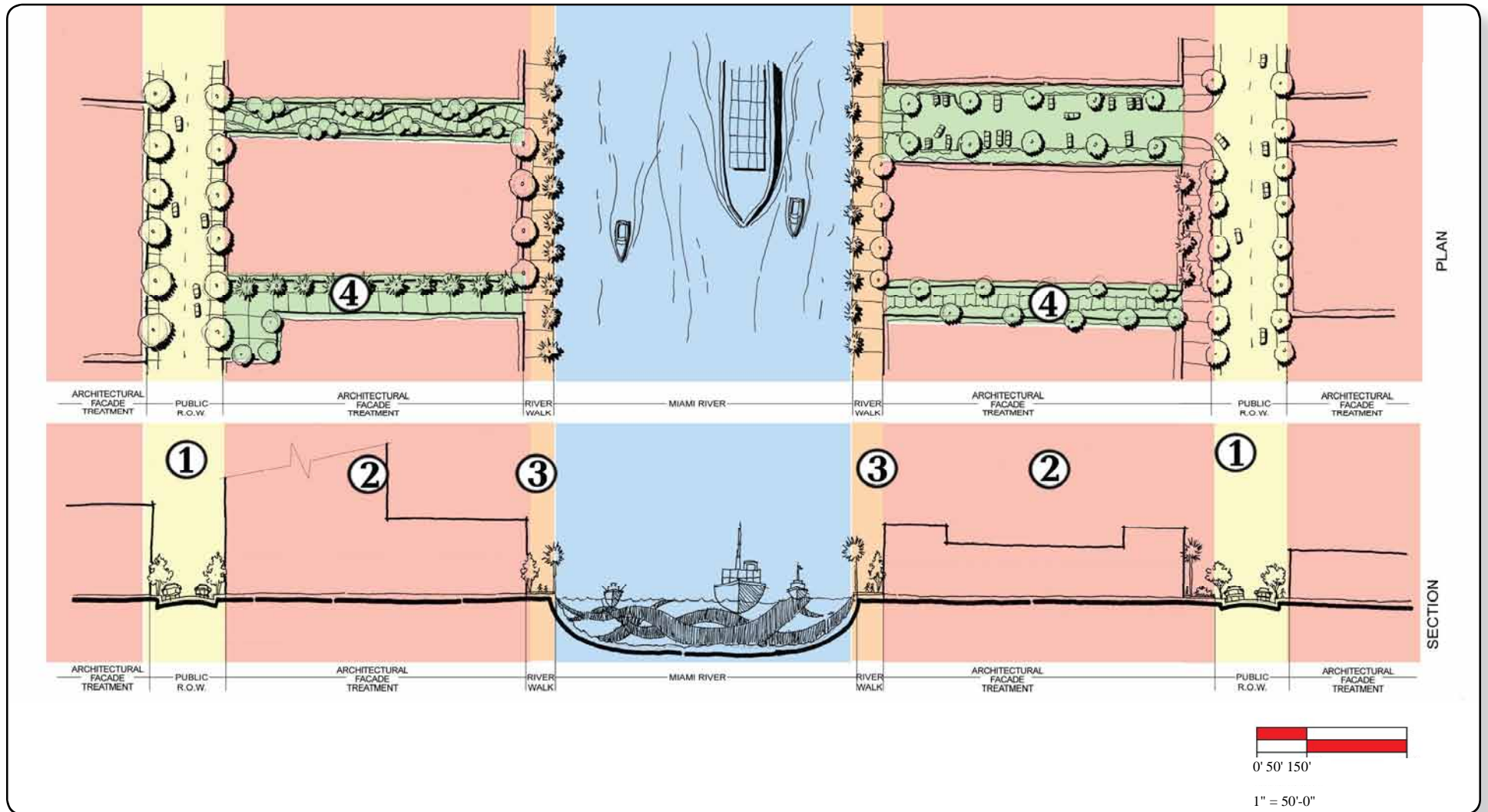

MIDDLE RIVER SECTION OUTLINE

To User:

This page contains a ‘cheat sheet’ for guiding the user through this chapter of the workbook. Each zone has a list of design elements that is included within that particular zone. Each zone is also color coded. The color is shown on the edges of the pages that belong to that zone.

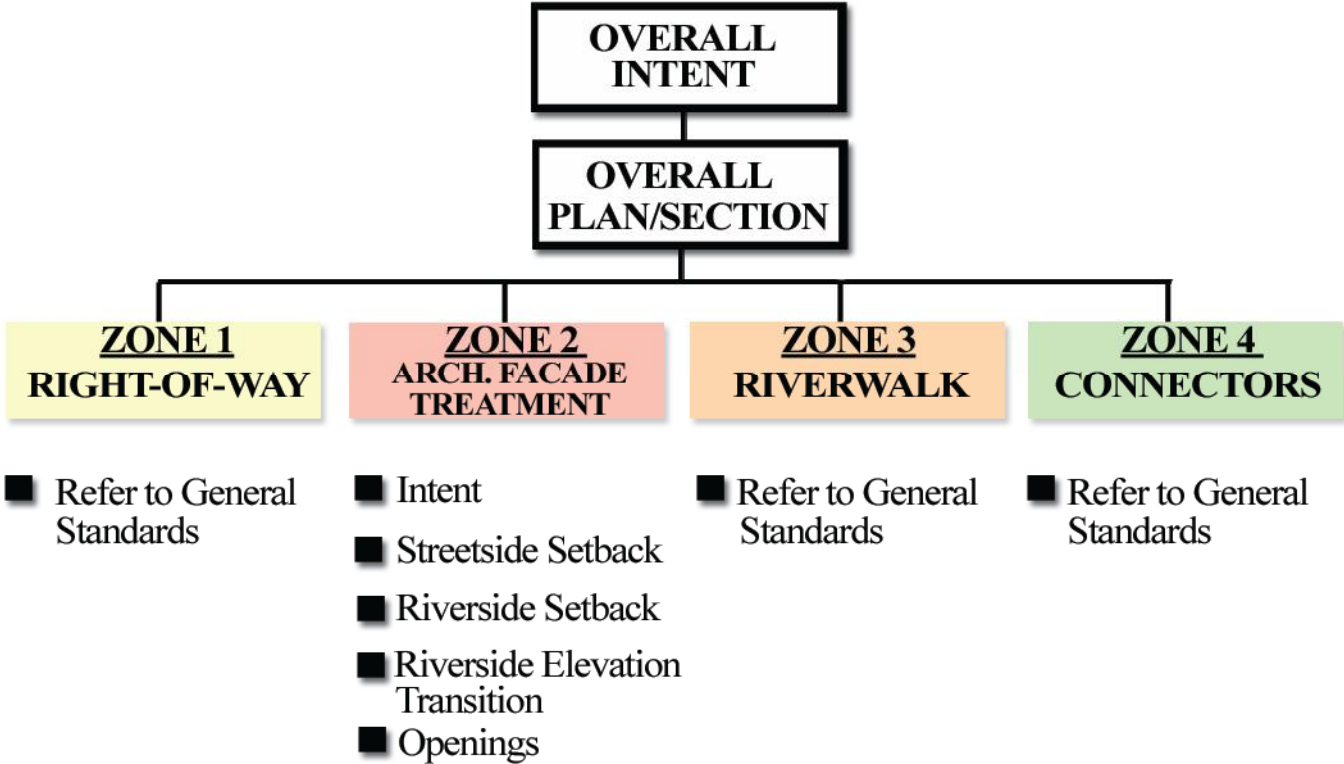

**ZONE 1 – STREET RIGHT-OF-WAY
REFER TO GENERAL STANDARDS**

ZONE 2 – ARCHITECTURAL FACADE TREATMENTS

ZONE 2 – ARCHITECTURAL FACADE TREATMENTS

Overall Background/Intent

The private property development along the Miami River should relate to the public realm in scale and character in order for the corridor to achieve its maximum potential for urban quality. The following section focuses on developing standards for the private properties abutting the right-of-ways of the Miami River corridor.

Included in this section are the following standards:

- Streetside Setback
- Riverside Setback
- Riverside Elevation Transition
- Openings



This Riverfront property engages the public realm with seating, shade and active store fronts.

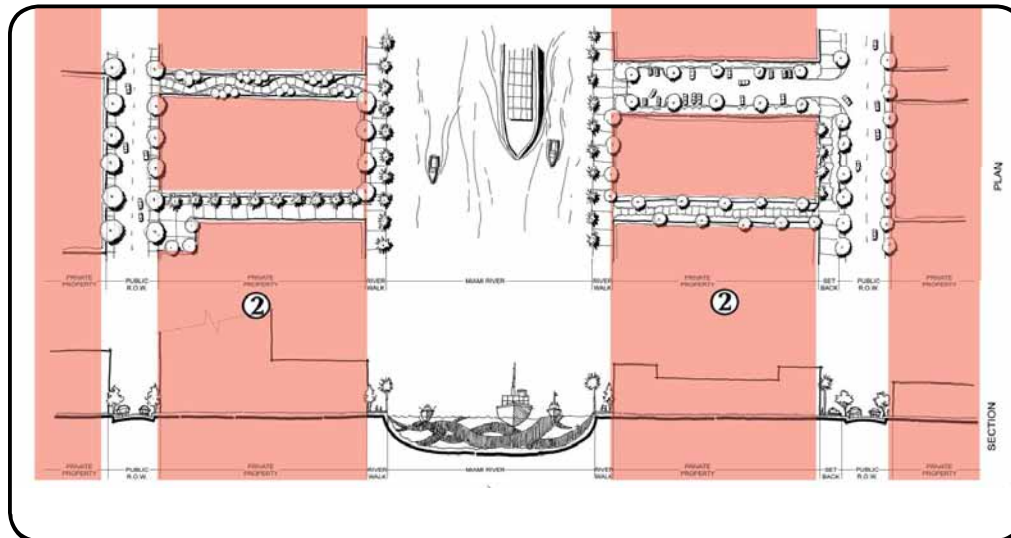

Key Map

ZONE 2 – ARCHITECTURAL FACADE TREATMENTS

Streetside Setback

Background/Intent

Front setbacks offer a great opportunity for urban amenities. This can include arcades, cafe seating, landscape or additional sidewalk width.

The intent of this standard is to provide a consistent setback while allowing for some variation to promote physical diversity in the corridor.

Standard

For mixed-use residential/office buildings, the setback shall be 10' from the right-of-way with an allowable 8' encroachment for awnings or canopies. If an arcade is used, the setback is 0' with an allowable encroachment maximum 3' from edge of curb into the right-of-way for awnings or canopies. Arcades shall be a minimum of 15'.

For industrial properties, refer to Upper River/Zone 2 Private Property/ Streetside Setback Standards.

This can be accomplished applying the following criteria:

- Setback areas are encouraged to include cafe seating if the abutting business suits the need. Cafe seating may not encroach into the public right-of-way.
- Paving materials shall either match the public side walk or be of a comparable material and color.
- If the adjacent building use requires a landscape buffer (i.e. blank wall), such area may be utilized for appropriate landscaping.
- Store owners may utilize potted plants within the setback area to delineate seating areas.

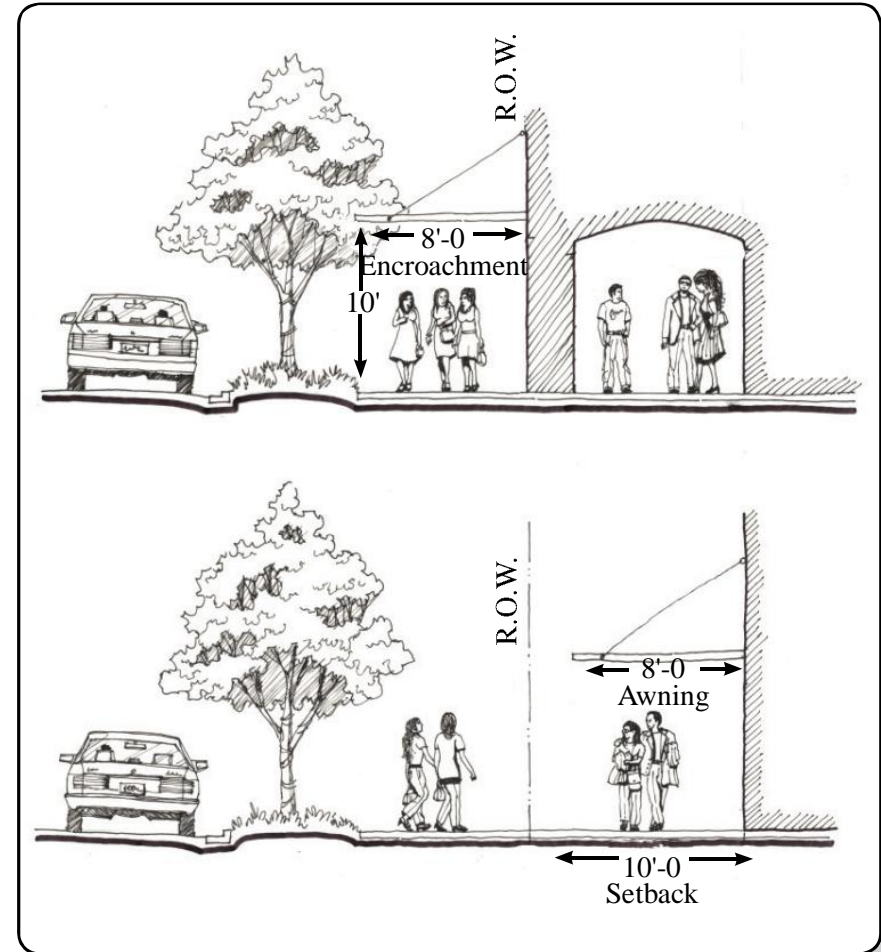

Streetside setback areas are shown above

ZONE 2 – ARCHITECTURAL FACADE TREATMENTS

Riverside Setback

Background/Intent

In order to create active and meaningful spaces along the riverwalk, buildings shall be set back appropriately, and the setback area should incorporate a variety of uses. This can include cafes, plazas/parks, walkways and seating areas. In addition, the design of these areas is critical to their success (Refer to Zone 3 – Riverwalk Standards for additional information).

Standard

Waterfront Setbacks shall be a minimum of 50 feet provided along any waterfront, except where the depth of the Lot is less than 200 feet the Setback shall be a minimum of 25% of the Lot depth; and except for Single & Duplex Residential and Non-Marine Related Industrial uses, where a minimum Setback of 20 feet shall be provided, except where the depth of the Lot is less than 80 feet the Setback shall be a minimum of 25% of the Lot depth.

This can be accomplished applying the following criteria:

- Setback shall be spaces consisting of a variety of uses, as mentioned above.
- Materials shall either match the public sidewalk or be of a comparable material and color.
- If the adjacent building use requires a landscape buffer (i.e. blank wall), such area may be utilized for appropriate and tasteful landscaping.
- Store owners may utilize potted plants within the setback area to delineate seating areas.

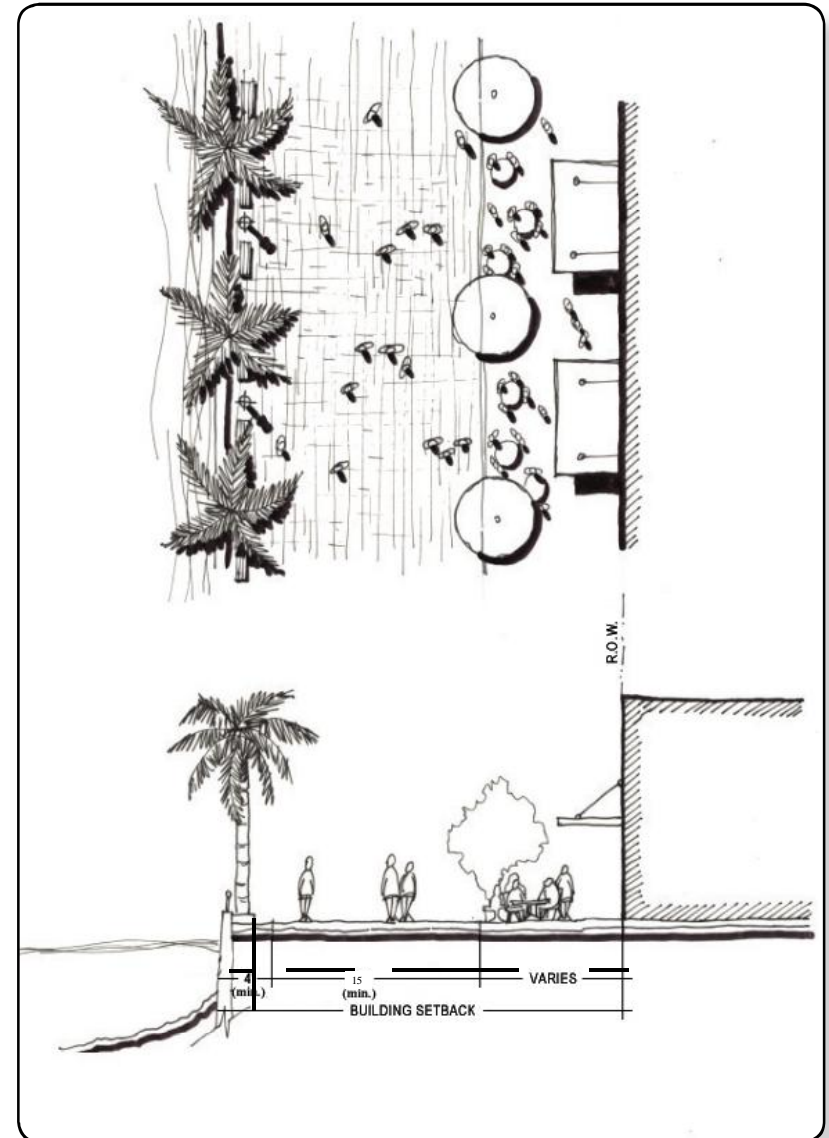

Typical Riverside setback

ZONE 2 – ARCHITECTURAL FACADE TREATMENTS

Riverside Elevation Transition

Background/Intent

Buildings shall be accessible, not only to adhere to ADA codes, but to encourage pedestrian flow and connectivity to and from the street. Designers should strive to create gradual transitions from the street to the entryway of the buildings that respond to flood zone requirements.

Standard

Elevation changes shall be addressed by gradual increments where possible.

This can be accomplished by applying the following criteria:

- The accessible route into the building should not detract from the primary entrance.
- The ramp or other feature shall blend with the architecture in color and in style.

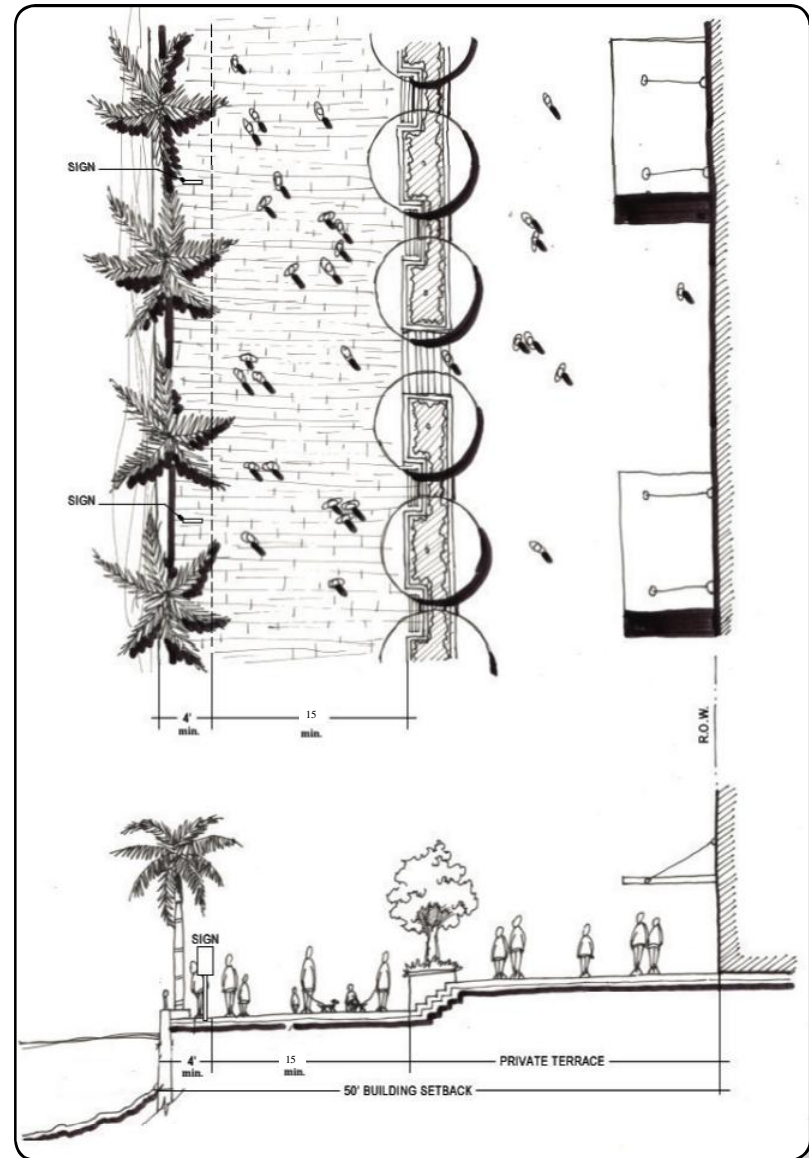

The grade transition in this option is used as a landscape buffer between the riverwalk and the private terrace. This buffer can incorporate seating, shade, lighting, and signage opportunities.

ZONE 2 – ARCHITECTURAL FACADE TREATMENTS

Riverside Elevation Transition

For narrow/restrictive conditions:

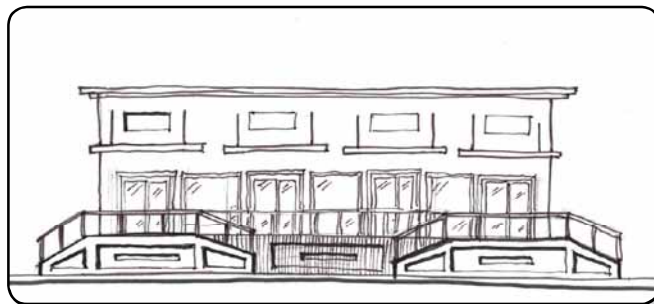

Elevation showing articulated facade treatment such as reliefs.

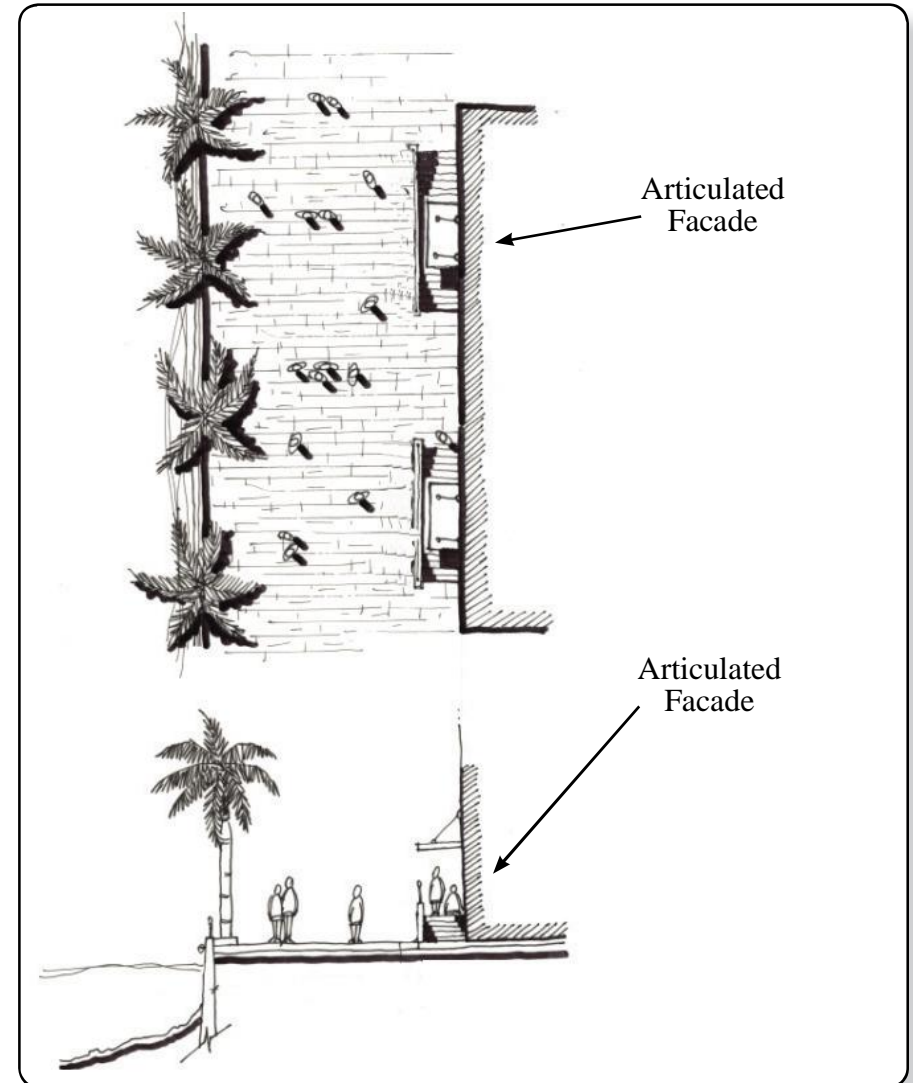

This grade transition may be necessary in lots where there is a narrow setback condition.

**ZONE 3 – RIVERWALK
REFER TO GENERAL STANDARDS**

**ZONE 4 – CONNECTORS
REFER TO GENERAL STANDARDS**

UPPER RIVER

UPPER RIVER

Introduction

Background/Intent

The Upper River section of the Miami River extends from 27th Avenue to Palmer Lake. This section includes the Miami Industrial, Grapeland Heights and Melrose Neighborhoods and the Miami Intermodal Center (MIC) Development. The character of the upper river is primarily industrial, water-related uses that serve as the transfer point for cargo and for the boat industry.

The intent of these standards is to enhance the quality of the private and public identity along this area while maintaining the ‘working river’ capability that is vital to the City of Miami. This includes providing for the needs of existing marine industrial zoned properties which require direct access to the River, as well as rezoned properties that become residential, which would benefit more from the presence of a continuous riverwalk.



The Upper River is characterized as the marine industrial hub of the Miami River.

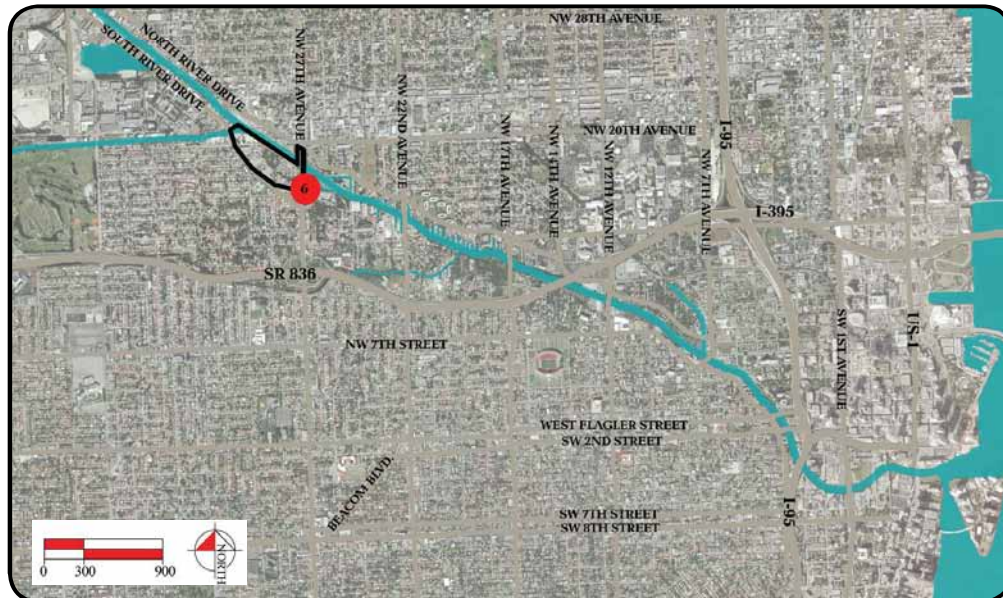

Key Map – Upper River Delineated in Black

Legend

6. Miami River Rapids Park

OVERALL PLAN AND SECTION

Introduction

The overall plan and section shown on the following page establishes the general physical criteria for the various components within each area of the River, including: Right-of-Way, Private Property, Riverwalk, Connectors, and the River itself.

The purpose of the overall plan and section is to give the user a comprehensive understanding of the desired character of each subarea. It is not intended to represent the only possible scenario. The proceeding section will focus on each individual component of the overall cross-section and plan, and develop specific design standards to guide future development, both public and private, along the Miami River Corridor.

UPPER RIVER – OVERALL PLAN AND SECTION

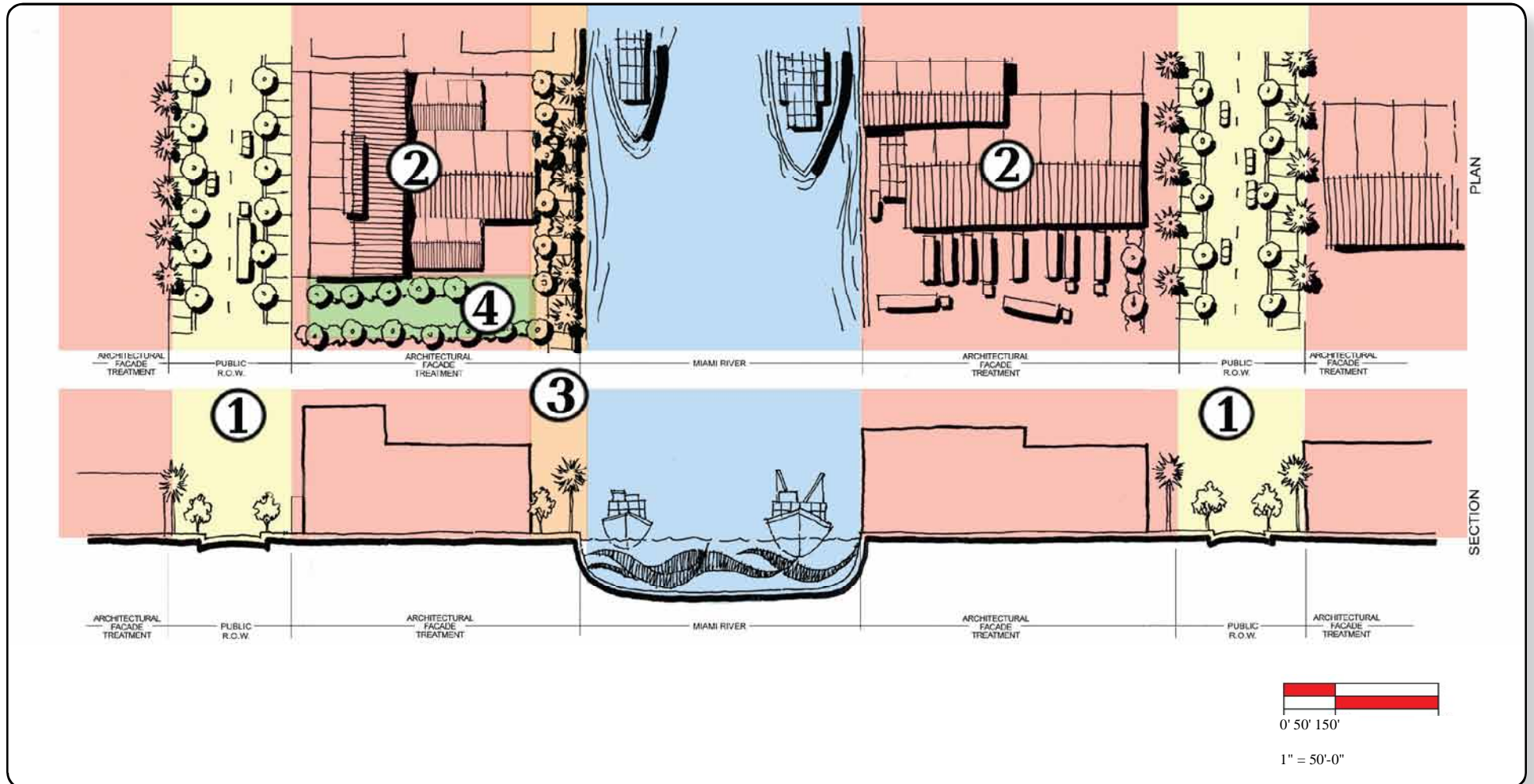

UPPER RIVER SECTION OUTLINE

To User:

This page contains a 'cheat sheet' for guiding the user through this chapter of the workbook. Each zone has a list of design elements that is included within that particular zone. Each zone is also color coded. The color is shown on the edges of the pages that belong to that zone.

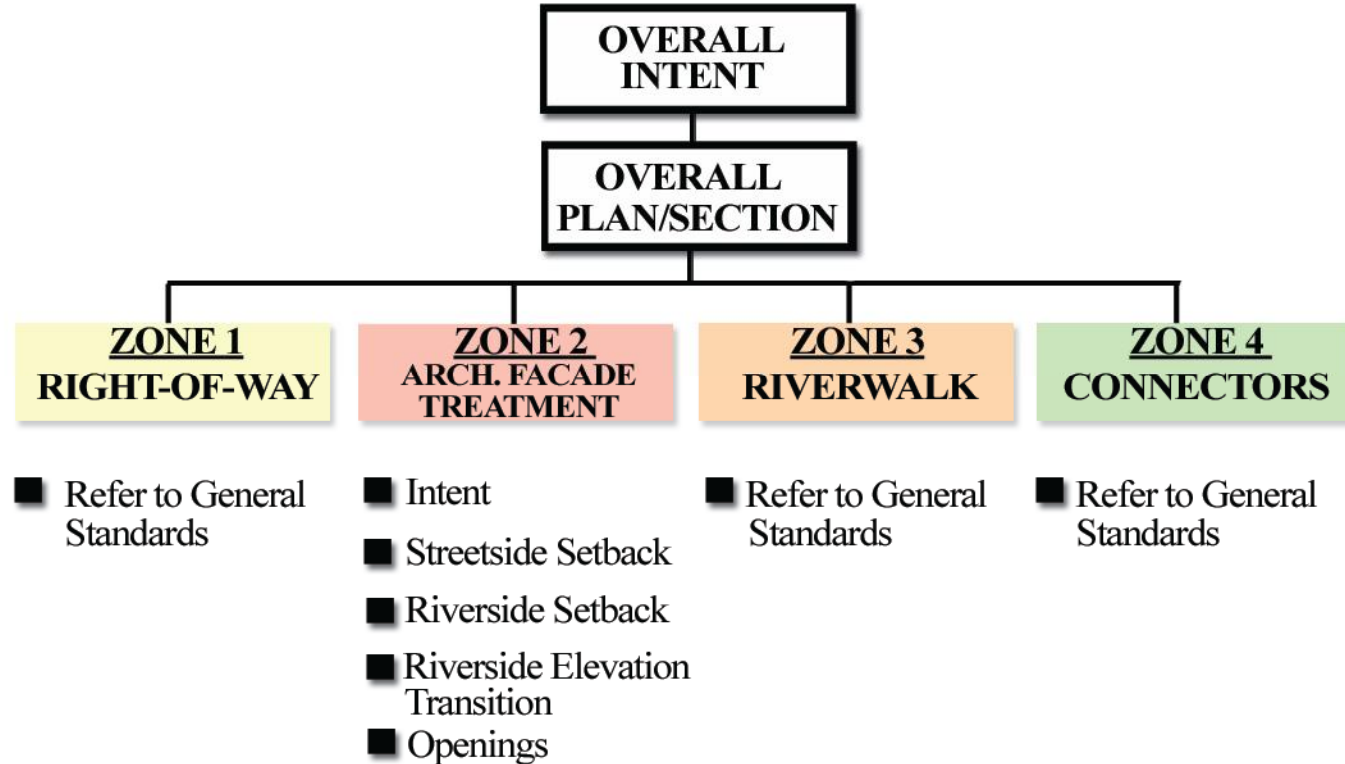

**ZONE 1 – STREET RIGHT-OF-WAY
REFER TO GENERAL STANDARDS**

ZONE 2 – ARCHITECTURAL FACADE TREATMENTS

ZONE 2 – ARCHITECTURAL FACADE TREATMENTS

Introduction

Overall Background/Intent

The private property development along the Miami River should relate to the public realm in scale and character in order for the corridor to achieve its maximum potential for urban quality. The following section focuses on developing standards for the private properties abutting the right-of-ways of the Miami River corridor.

Included in this section are the following standards:

- Streetside Setback
- Riverside Setback
- Streetside Elevation Transition
- Streetside Transparency
- Scaling
- Openings
- Entrances
- Storefronts
- Materials
- Streetside Awnings, Arcades and Colonnades
- Lighting
- Signage
- Public Accessibility



Warehouse facades can be clad with architectural elements and landscaped to provide a more pleasing connection to the street and enhance the overall quality of the neighborhood.

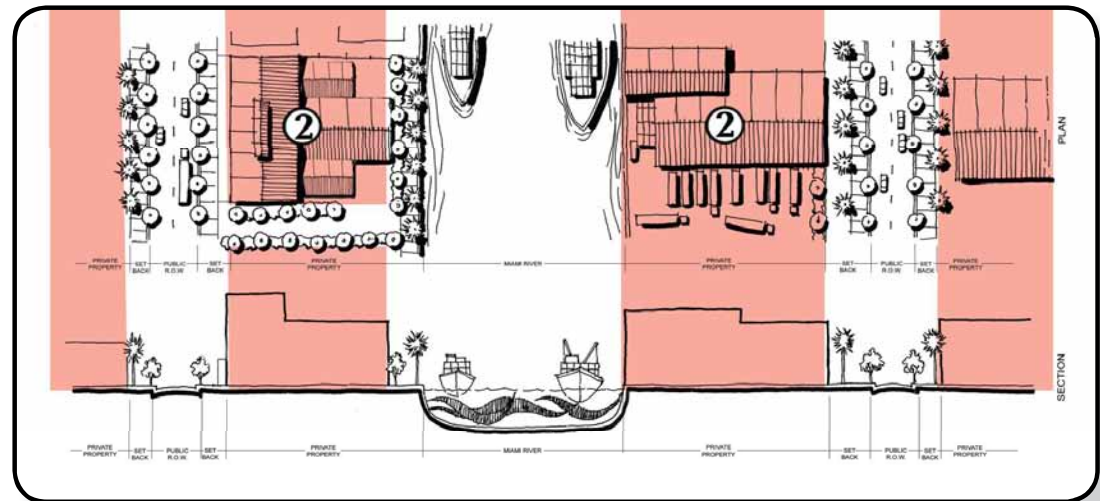

Key Map

ZONE 2 – ARCHITECTURAL FACADE TREATMENTS

Streetside Setback

Background/Intent

The setback along the streetfront is an important element that will help define the future urban make-up of the upper river. This setback should be regulated based on two primary elements: scale of the building and use.

Standard

All Non-Marine related industrial uses shall be setback a minimum of 10' from the street unless an arcade is provided, in which case it can be placed along the property line. Marine related industrial establishments shall be setback a minimum of 5'.

This can be accomplished applying the following criteria:

- Materials shall either match the public sidewalk or be of a comparable material and color.
- If the adjacent building use requires a landscape buffer (i.e. blank wall), such area may be utilized for appropriate and tasteful landscaping.
- No parking shall be allowed within the setback.
- Setback area shall be landscaped to appropriately buffer blank walls from streetscape.

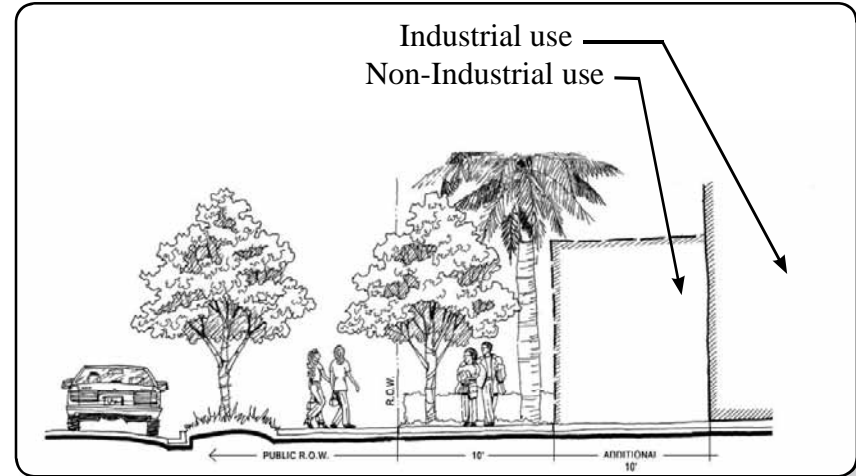

Streetside setback

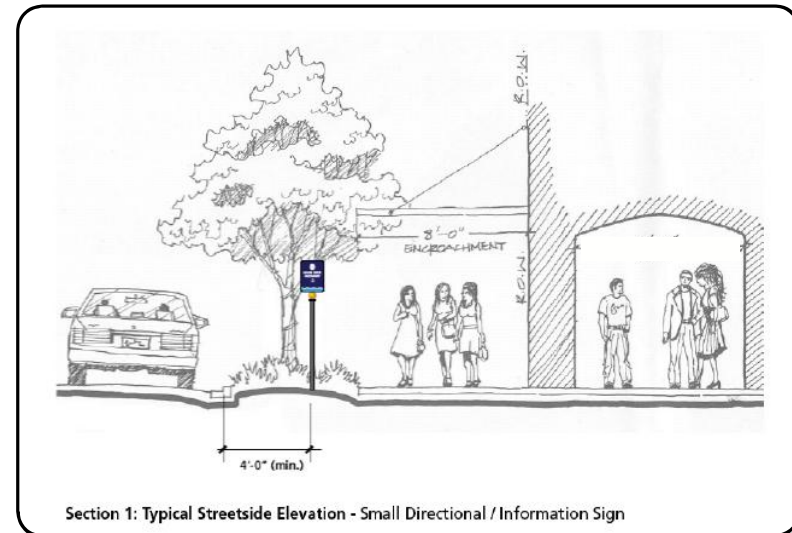

Facade incorporating an arcade and awning.

ZONE 2 – ARCHITECTURAL FACADE TREATMENTS

Riverside Setback

Background/Intent

Many of the businesses that characterize this part of the River are marine industrial and depend on direct access to the River. In these cases, a riverwalk does not apply to the property. Where marine industrial zoned properties get rezoned to residential or mixed use, it become appropriate to establish a riverwalk to enhance the quality of those developments.

Standard

Waterfront Setbacks shall be a minimum of 50 feet provided along any waterfront, except where the depth of the Lot is less than 200 feet the Setback shall be a minimum of 25% of the Lot depth; and except for Single & Duplex Residential and Non-Marine Related Industrial uses, where a minimum Setback of 20 feet shall be provided, except where the depth of the Lot is less than 80 feet the Setback shall be a minimum of 25% of the Lot depth.

- The setback may be utilized for spaces consisting of a variety of uses, such as loading, crane operation, storage of non-hazardous materials..

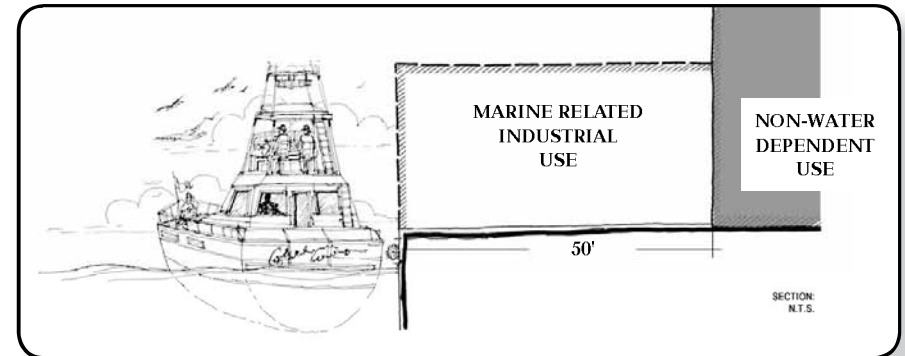

Riverside setback

**ZONE 3 – RIVERWALK
REFER TO GENERAL STANDARDS**

**ZONE 4 – CONNECTORS
REFER TO GENERAL STANDARDS**

APPENDIX

APPENDIX

APPENDIX A

Plant Material

APPENDIX B

Hardscape Material

APPENDIX C

Site Furniture

APPENDIX D

Wayfinding Program

APPENDIX E

Crime Prevention Through Environmental Design



APPENDIX F

Plant Maintenance/Tree Protection



APPENDIX G



Description of Jurisdictional Activities and Required Approvals For River-related Improvements

APPENDIX A – PLANT MATERIAL



ACCENT PLANT	SCIENTIFIC NAME	COMMON NAME	OVERALL HEIGHT
	<p>Bromeliad</p>	<p>Bromeliad Varieties</p>	<p>3-5'</p>
	<p>Strelitzia reginae</p>	<p>Bird of Paradise</p>	<p>4-6'</p>
	<p>Crinum X Amabile</p>	<p>Crinum Lily</p>	<p>4-6'</p>



MIAMI RIVER *Greenway Regulatory Design Standards*

ACCENT PLANT	SCIENTIFIC NAME	COMMON NAME	OVERALL HEIGHT
	<p>Alpinia zerumbet</p>	<p>Shell Ginger</p>	<p>3-5'</p>
	<p>Camellia j aponica</p>	<p>Camellia</p>	<p>6-10'</p>
	<p>Spathiphyllum</p>	<p>Peace Lily</p>	<p>4-6'</p>



SHRUBS	SCIENTIFIC NAME	COMMON NAME	OVERALL HEIGHT
	<p>Raphiolepis indica</p>	<p>Indian Hawthorn</p>	<p>2'-2 1/2'</p>
	<p>Jasminum multiflorum</p>	<p>Jasmine</p>	<p>2'-3'</p>
	<p>Chrysobalanus icaco</p>	<p>Cocoplum</p>	<p>2'-4'</p>



MIAMI RIVER *Greenway Regulatory Design Standards*

SHRUBS	SCIENTIFIC NAME	COMMON NAME	OVERALL HEIGHT
	<p>Podocarpus</p>	<p>Podocarpus</p>	<p>2'-3'</p>
	<p>Schefflera arboricola 'Trinette'</p>	<p>Dwarf Variegated Schefflera</p>	<p>4'-8'</p>
	<p>Rapanea guinensis</p>	<p>Florida Myrsine</p>	<p>4'-8'</p>



FLOWERING TREES	SCIENTIFIC NAME	COMMON NAME	OVERALL HEIGHT
	<p>Jacaranda mimosifolia</p>	<p>Jacaranda</p>	<p>to 30'</p>
	<p>Hibiscus Sp.</p>	<p>Hibiscus</p>	<p>to 15'</p>
	<p>Lagerstroemia indica</p>	<p>Crape Myrtle</p>	<p>15-20'</p>



MIAMI RIVER *Greenway Regulatory Design Standards*

FLOWERING TREES	SCIENTIFIC NAME	COMMON NAME	OVERALL HEIGHT
	<p>Tabebuia heterophylla</p>	<p>Pink Tabebuia</p>	<p>12-15'</p>
	<p>Bulnesia arborea</p>	<p>Verawood</p>	<p>to 15'</p>
	<p>Peltophorum dubium</p>	<p>Yellow Poinciana</p>	<p>to 15'</p>



LARGE CANOPY TREES	SCIENTIFIC NAME	COMMON NAME	OVERALL HEIGHT
	<p>Swietenia mahagoni</p>	<p>Mahogany</p>	<p>to 50'</p>
	<p>Quercus virginiana</p>	<p>Live Oak</p>	<p>40-60'</p>
	<p>Bursera simaruba</p>	<p>Gumbo Limbo</p>	<p>30-50'</p>



MIAMI RIVER *Greenway Regulatory Design Standards*

LARGE CANOPY TREES	SCIENTIFIC NAME	COMMON NAME	OVERALL HEIGHT
	<p>Lysiloma latisiliqua</p>	<p>Wild Tamarind</p>	<p>to 50'</p>
	<p>Calophyllum brasiliense</p>	<p>Brazilian Beauty Leaf</p>	<p>to 40'</p>
	<p>Delonix regia</p>	<p>Royal Poinciana</p>	<p>30-50'</p>

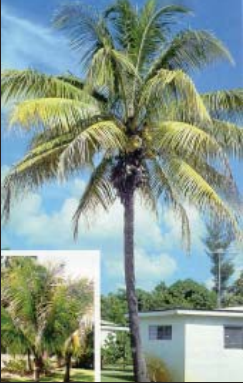

LARGE PALMS	SCIENTIFIC NAME	COMMON NAME	OVERALL HEIGHT
	<p>Phoenix canariensis</p>	<p>Canary Island Date Palm</p>	<p>to 40'</p>
	<p>Washingtonia robusta</p>	<p>Mexican Fan Palm</p>	<p>20-30'</p>
	<p>Sabal palmetto</p>	<p>Cabbage Palm</p>	<p>20-40'</p>

MIAMI RIVER *Greenway Regulatory Design Standards*

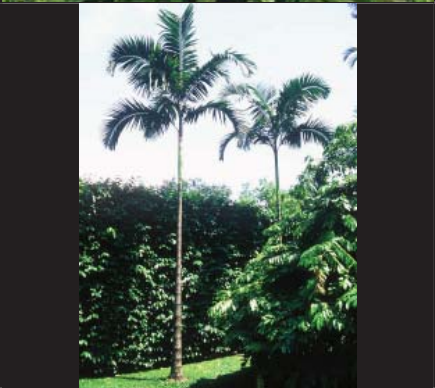

LARGE PALMS	SCIENTIFIC NAME	COMMON NAME	OVERALL HEIGHT
	<p>Roystonea elata</p>	<p>Royal Palm</p>	<p>25-35'</p>
	<p>Cocos nucifera 'Green Malayan' or 'Maypan'</p>	<p>Coconut Palm</p>	<p>to 30'</p>
	<p>Phoenix dactylifera 'Medjool'</p>	<p>Medjool Date Palm</p>	<p>30-40'</p>

SMALL PALMS	SCIENTIFIC NAME	COMMON NAME	OVERALL HEIGHT
	<p><i>Archontophoenix alexandrae</i></p>	<p>Alexandra Palm</p>	<p>15'-25'</p>
	<p><i>Beaucarnea recurvata</i></p>	<p>Bottle Palm</p>	<p>8-12'</p>
	<p><i>Veitchia montgomeryana</i></p>	<p>Montgomery Palm</p>	<p>12-15'</p>



MIAMI RIVER *Greenway Regulatory Design Standards*

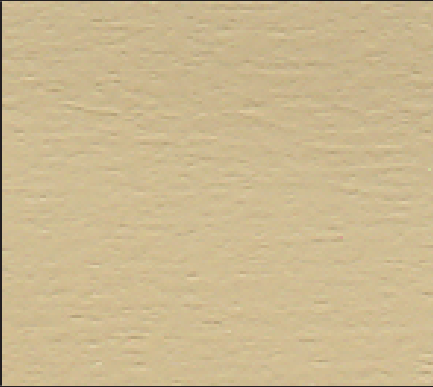

SMALL PALMS	SCIENTIFIC NAME	COMMON NAME	OVERALL HEIGHT
	<p>Rhaps excelsa</p>	<p>Lady Palm</p>	<p>4-6'</p>
	<p>Thrinaz radiata</p>	<p>Thatch Plam</p>	<p>15-25'</p>
	<p>Chamaedorea cataractarum</p>	<p>Cat Palm</p>	<p>4-6'</p>

APPENDIX B

HARDSCAPE	HARDSCAPE TYPE	COLOR/SPECS.	LOCATION
	<p>Standard Gray Concrete Sidewalk</p>	<p>City Standard</p>	<p>Greenway (Non-Corridor Side) Riverwalk Private Courtyards Plazas</p>
	<p>Integral Colored Concrete Sidewalk</p>	<p>Beige C-12 (Greenway)</p>	<p>Private Courtyards Plazas Greenway Riverwalk Pedestrian Connections</p>
	<p>Concrete Paver Sidewalk</p>		<p>Private Courtyards Plazas Riverwalk Pedestrian Connections</p>



MIAMI RIVER *Greenway Regulatory Design Standards*

HARDSCAPE	HARDSCAPE TYPE	COLOR/SPECS.	LOCATION
	<p>Brick Pavers</p>		<p>Private Courtyards Plazas Riverwalk Pedestrian Connections</p>
	<p>Concrete Paver Intersection</p>		<p>Greenway</p>
	<p>Integral Color Concrete Crosswalk</p>		<p>Crosswalks on Greenway</p>



FURNITURE	HARDSCAPE TYPE	COLOR/SPECS.	LOCATION
	<p>Thermoplastic Striping Crosswalk</p>		<p>Crosswalks</p>
	<p>Brick Paver Crosswalk</p>	<p>Varies</p>	<p>Greenway</p>
	<p>Paver Parking Lot</p>	<p>Varies</p>	<p>Private Parking Areas</p>

MIAMI RIVER *Greenway Regulatory Design Standards*

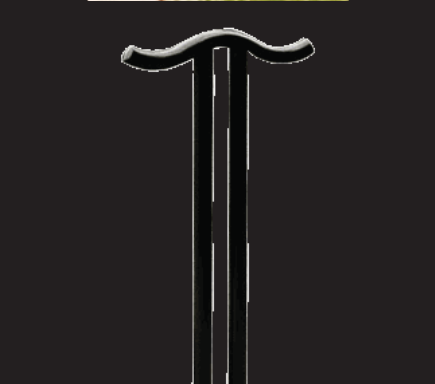
APPENDIX C



FURNITURE	FURNITURE TYPE/NAME	MANUFACTURER	COLOR/SPECS.	LOCATION
	<p>Plainwell Bench</p>	<p>Landscape Forms</p>	<p>Black with IPE Railing</p>	<p>Greenway/ Riverwalk</p>
	<p>Annapolis Bollard</p>	<p>Landscape Forms</p>	<p>Black</p>	<p>Intersections/ Riverwalk</p>
	<p>Pi Bike Rack</p>	<p>Landscape Forms</p>	<p>Black</p>	<p>Selected Intersections/ Gathering Areas</p>

** Note: All Furniture materials shall be as stated or of an equally approved manufacturer and quality.



FURNITURE	FURNITURE TYPE/NAME	MANUFACTURER	COLOR/SPECS.	LOCATION
	<p align="center">Plainwell Trash Receptacle</p>	<p align="center">Landscape Forms</p>	<p align="center">Black with IPE Wood</p>	<p align="center">Greenway/ Riverwalk</p>
	<p align="center">Custom Bus-Shelter</p>	<p align="center">Custom</p>		<p align="center">Per City Direction</p>
	<p align="center">Greenway Logo</p>	<p align="center">Custom</p>		<p align="center">Mounted on Greenway and Riverwalk Benches and Trash Receptacles</p>

** Note: All Furniture materials shall be as stated or of an equally approved manufacturer and quality.

MIAMI RIVER *Greenway Regulatory Design Standards*

FURNITURE	FURNITURE TYPE/NAME	MANUFACTURER	COLOR/SPECS.	LOCATION
	<p align="center">Newsrack</p>		<p align="center">Black</p>	<p align="center">Selected Intersections</p>
	<p align="center">Decorative Light Pole (Pedestrian)</p>	<p align="center">Aneron (FPL Decorative Package)</p>	<p align="center">Black</p>	<p align="center">Greenway/ Riverwalk</p>
	<p align="center">Decorative Light Pole (Roadway)</p>	<p align="center">Ameron (FPL Decorative Package)</p>	<p align="center">Black</p>	<p align="center">Greenway</p>

**** Note: All Furniture materials shall be as stated or of an equally approved manufacturer and quality.**

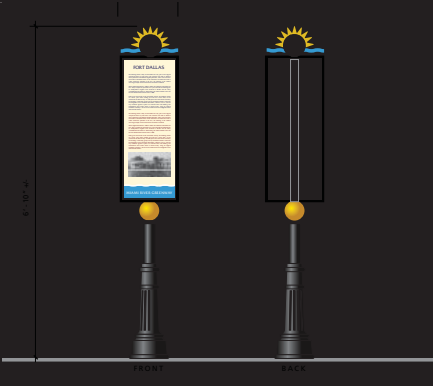
FURNITURE	FURNITURE TYPE/NAME	MANUFACTURER	COLOR/SPECS.	LOCATION
	<p>Landscape Up-Lighting</p>	<p>Allscape</p>	<p>Black</p>	<p>Greenway/ Riverwalk/ Private Courtyards/ Plazas</p>
	<p>Ground-Mount Up-Lighting</p>	<p>Lumascape</p>	<p>Black</p>	<p>Greenway/ Riverwalk/ Private Courtyards/ Plazas</p>
	<p>Special Wayfinding Signage</p>	<p>Custom</p>	<p>Black</p>	<p>Per City Direction</p>

** Note: All Furniture materials shall be as stated or of an equally approved manufacturer and quality.

APPENDIX D WAYFINDING PROGRAM



Section 3: Typical Riverwalk Elevation - Kiosk

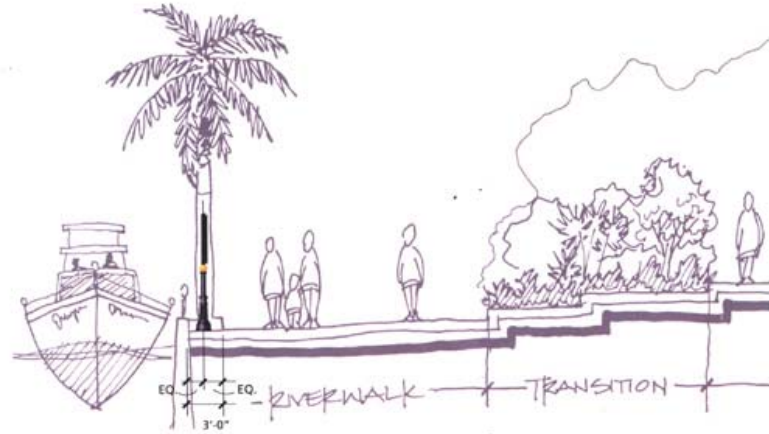

Section 3: Typical Riverwalk Elevation - Pedestrian Directional

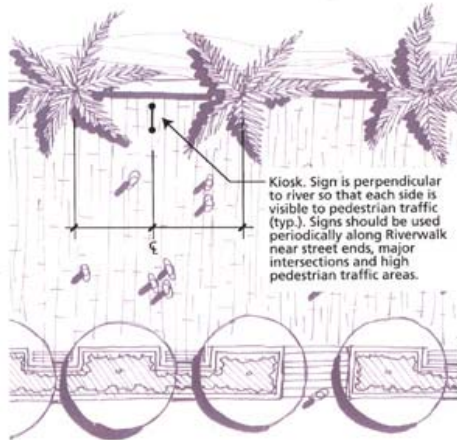

Section 3: Typical Riverwalk Plan - Kiosk



Kiosk

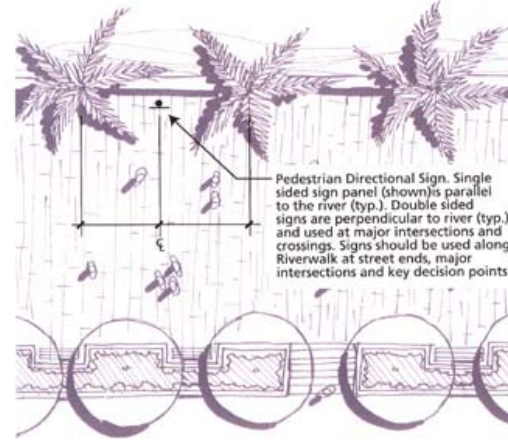

Section 3: Typical Riverwalk Plan - Pedestrian Directional



Pedestrian Directional Sign

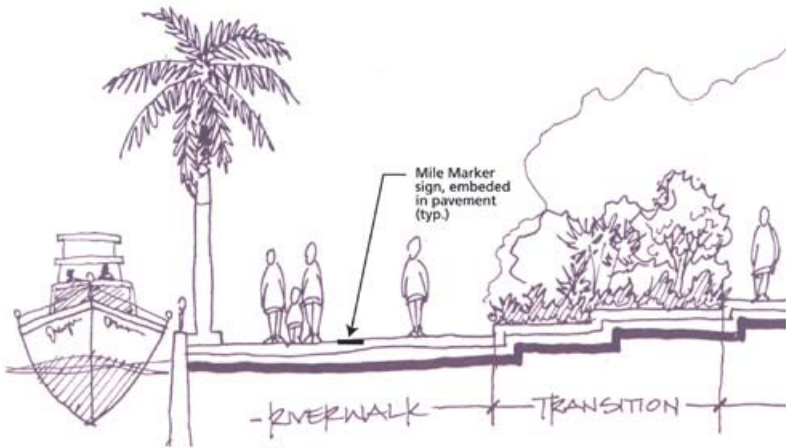

Section 3: Typical Riverwalk Elevation - Mile Marker

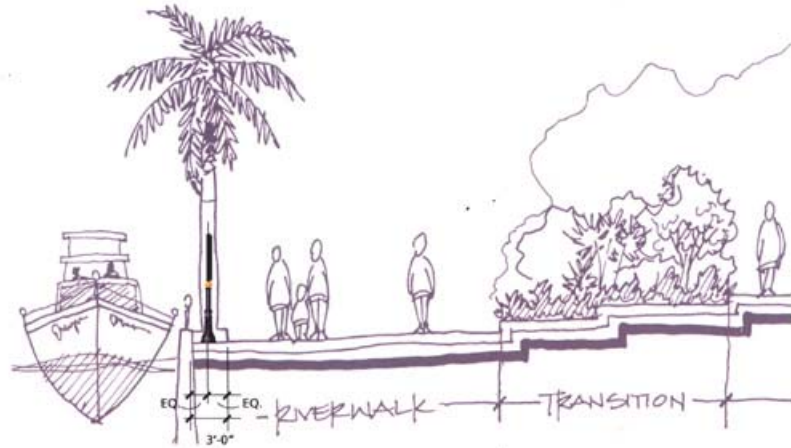

Section 3: Typical Riverwalk Elevation - Historical Marker

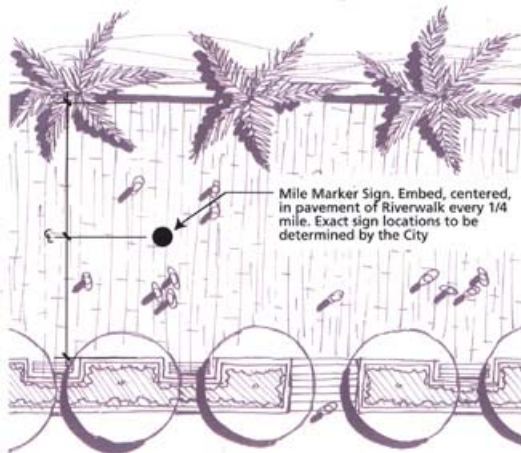

Section 3: Typical Riverwalk Plan - Mile Marker



Mile Marker Sign

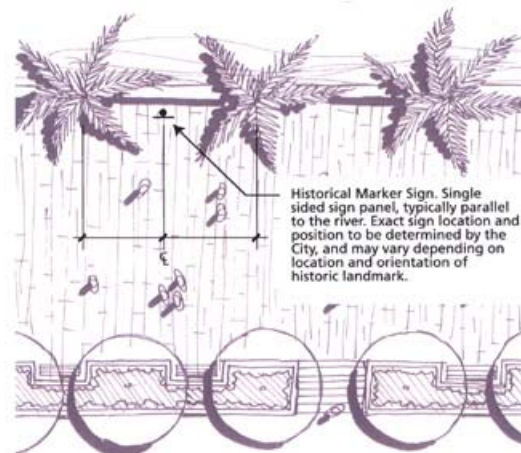

Section 3: Typical Riverwalk Plan - Historical Marker



Historical Marker Sign

MIAMI RIVER *Greenway Regulatory Design Standards*

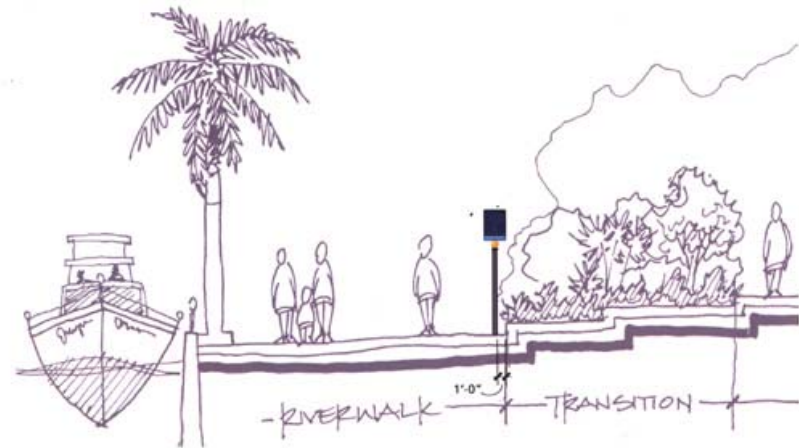
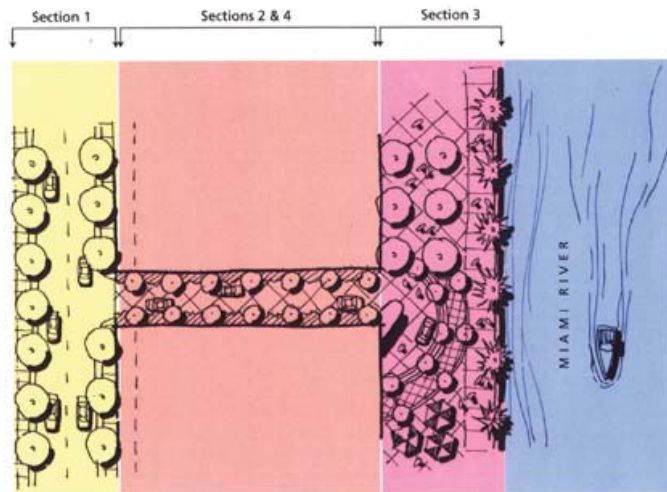

Section 3: Typical Riverwalk Elevation - Small Directional / Information Sign

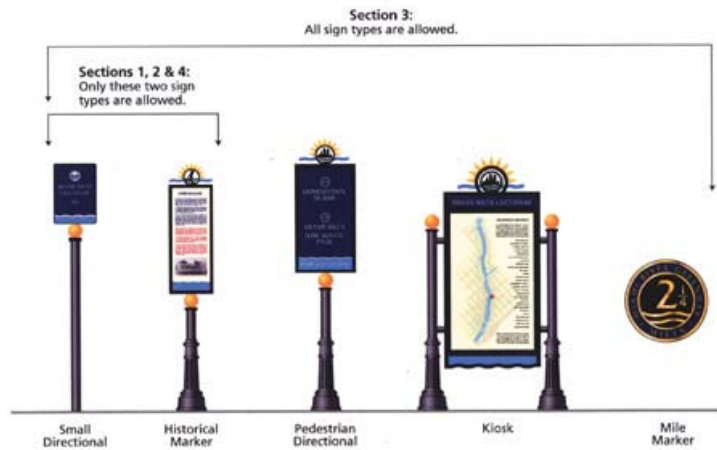

Typical Plan (Lower River) & Sign Types

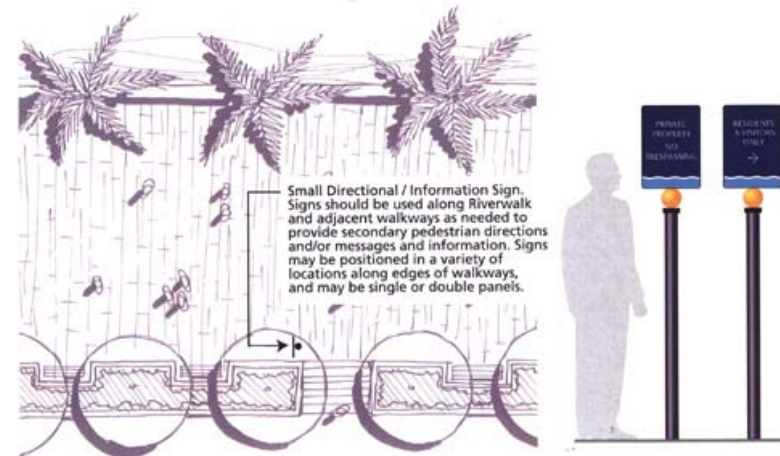

Section 3: Typical Riverwalk Plan - Small Directional / Information Sign

Small Directional / Information Sign





Pedestrian Directional Sign:

These freestanding directional signs are located periodically along the Miami River Greenway near major destinations and public parks, and at major intersections and decision points. The directional sign's purpose is to direct pedestrians to major public landmarks along the Miami River Greenway; to identify the Greenway "trail"; and reinforce a "sense of place" in the Miami River district. Sign locations should be integrated into landscape and/or paving plans, and should not be positioned next to other street furniture such as street lights, benches, trash cans etc. to avoid conflicts and visual clutter. Signs should not be positioned in a way that will interfere with the natural pedestrian flow.

Features:

- Painted or Powder Coated aluminum construction.
- Specific color scheme and graphics that complement other Greenway sign types and street furniture.
- Silk-screened aluminum sign panels (one each side), with directional text and "Greenway" identity.
- Decorative cast wrap-around bases on posts. Matches those used on other Greenway sign types.
- "Wave", "Sun" and "symbol" graphics on top of directory are water-jet cut and painted aluminum.
- Six "Miami River Greenway" symbols are used randomly atop the major sign types. Each symbol represents a different aspect of the Miami River (see page on "Miami River Symbols").

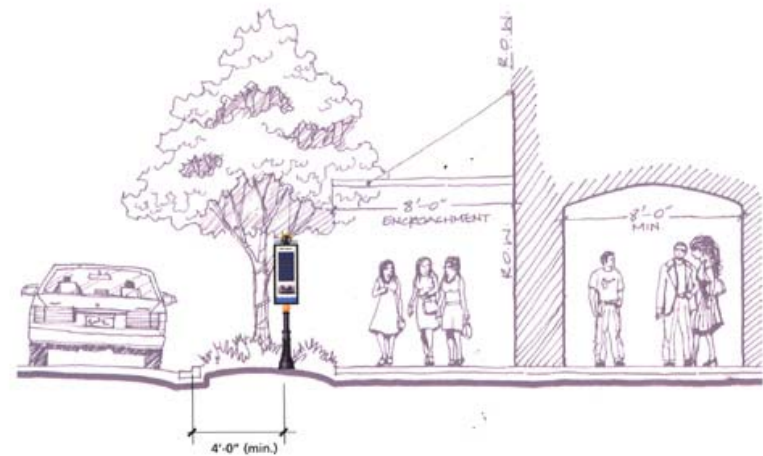

Section 1: Typical Streetside Elevation - Historical Marker

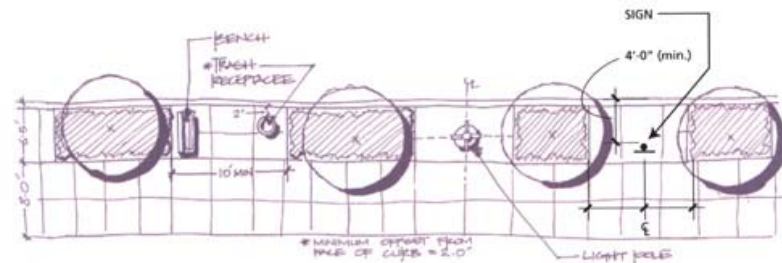

Note: Typically, sign is positioned along pedestrian route, in proximity to the designated historical landmark.

Section 1: Typical Streetside Plan - Historical Marker

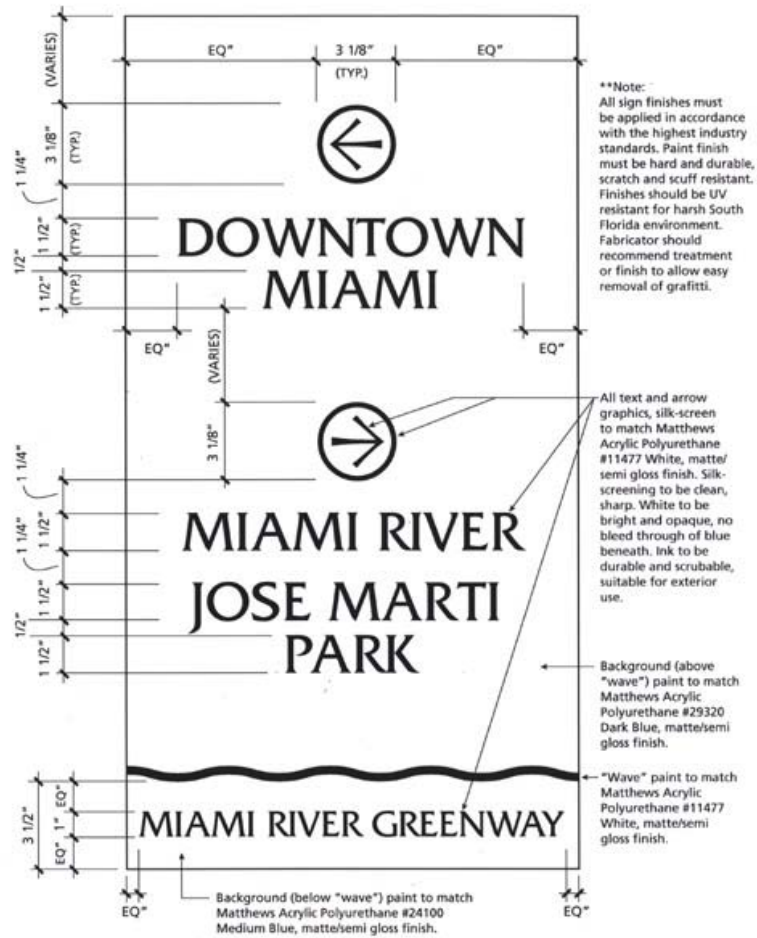

Pedestrian Directional Sign - Typical Sign Panel Dimensions
Scale: 3" = 1'-0"

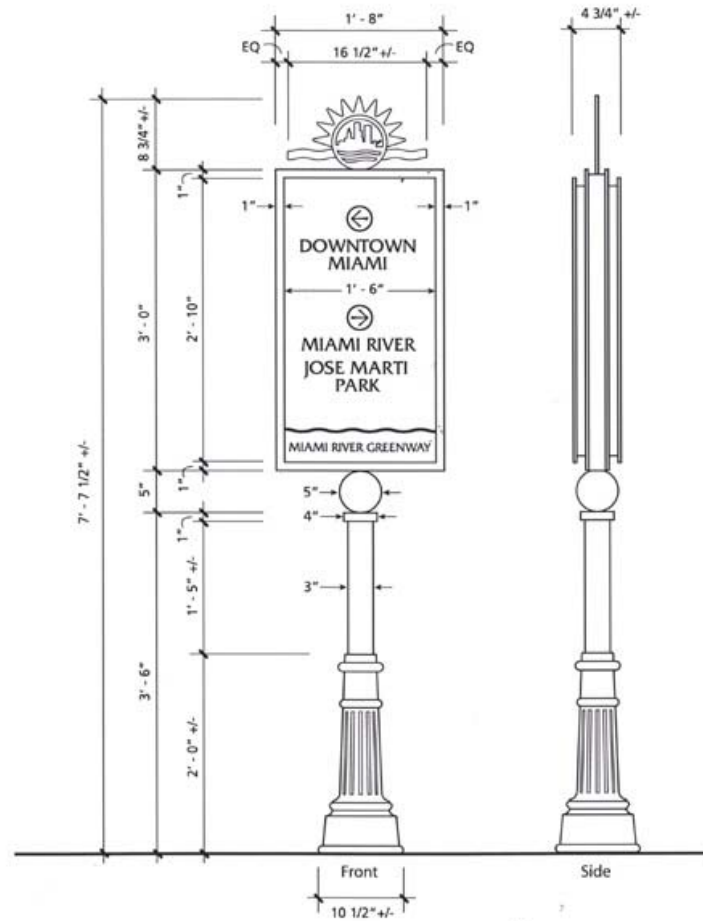

Pedestrian Directional Sign - Overall Dimensions
Scale: 1" = 1'-0"

MIAMI RIVER *Greenway Regulatory Design Standards*

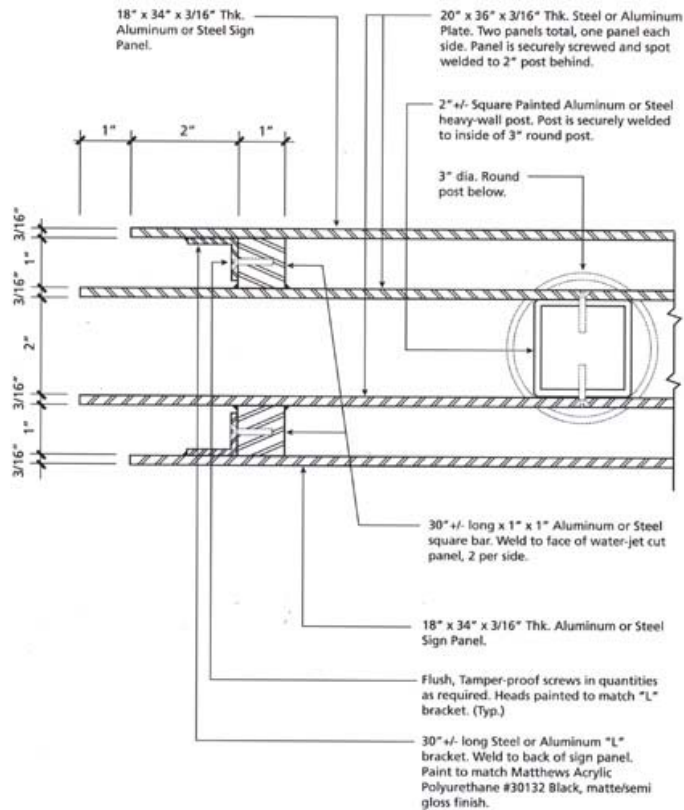

Pedestrian Directional Sign - Partial Horizontal Section A-A
Scale: Half Actual Size

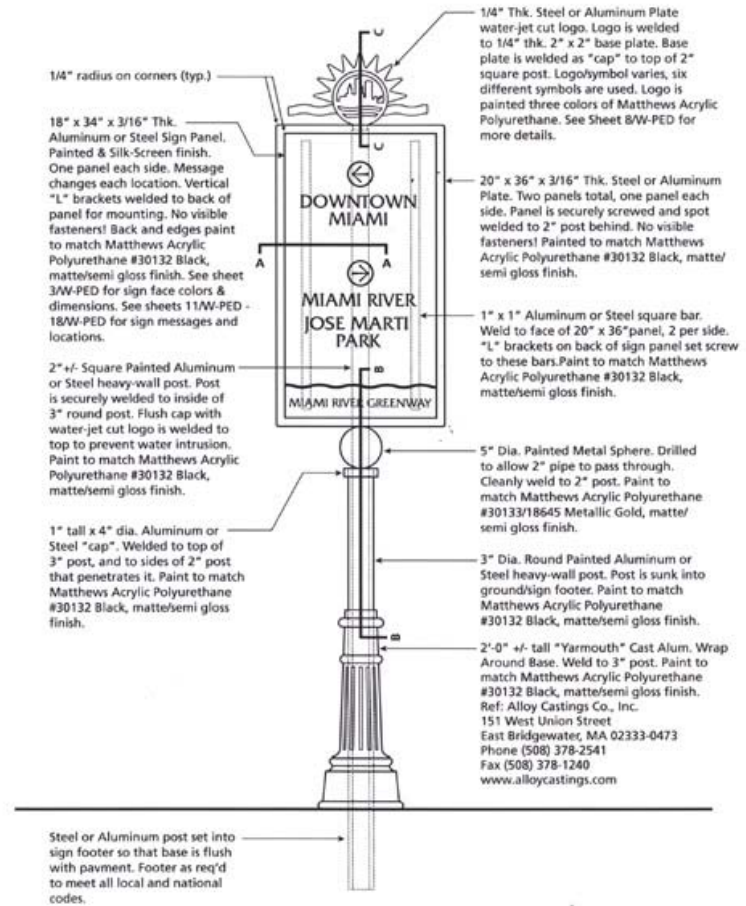

Pedestrian Directional Sign - Materials & Colors
Scale: 1" = 1'-0"

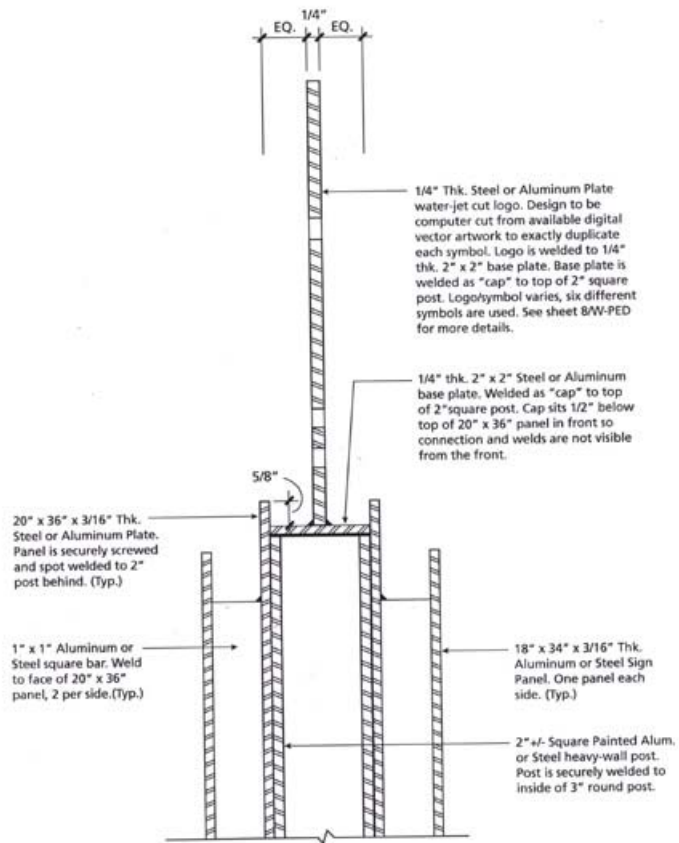

Pedestrian Directional Sign - Partial Vertical Section C-C
Scale: Half Actual Size

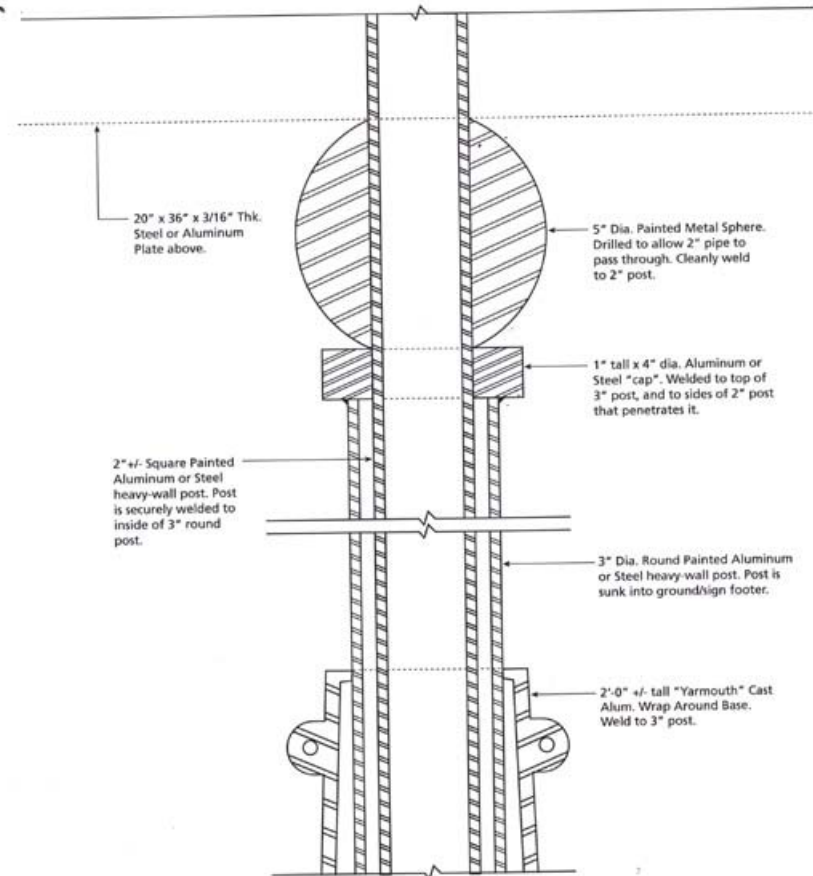

Pedestrian Directional Sign - Partial Vertical Section B-B
Scale: Half Actual Size

MIAMI RIVER *Greenway Regulatory Design Standards*

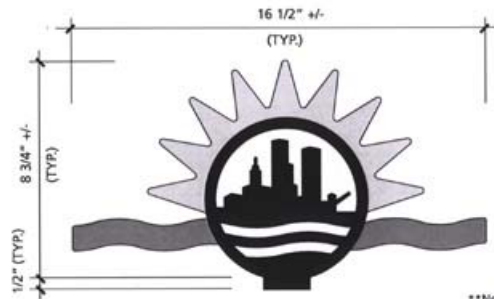

Symbol A

****Note:**
Symbols pictured were in final development at time of spec. document. Please obtain final versions from City prior to manufacture.



Symbol B



Symbol C

Pedestrian Directional Sign - Project Symbols 1
Scale: 3" = 1'-0"

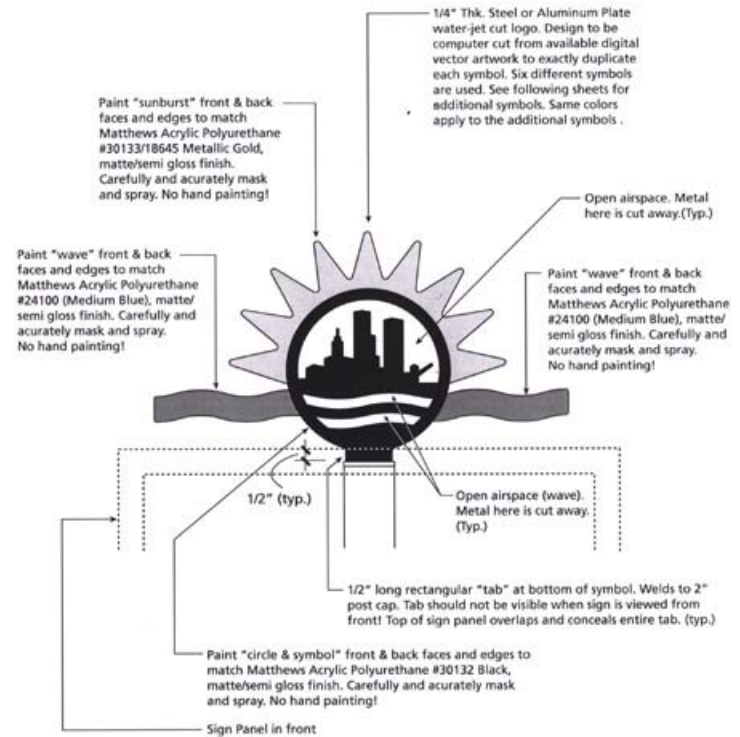

****Note:**
Symbol is water-jet cut out of (1) piece of metal plate. Color breaks are achieved by carefully masking and spraying "waves" and "sunburst". Router/laser cut masking from digital files should be used for precision. (1) sample must be supplied and approved for quality of metalwork and paint finish prior to full production. See following sheets for additional symbol layouts.

Pedestrian Directional Sign - Typical Symbol Specifications
Scale: 3" = 1'-0"



Pedestrian Kiosk:

These freestanding directories are located periodically along the Miami River Greenway near major destinations and public parks, and at major intersections or decision points. The kiosk's purpose is to orient pedestrians to their current location; to the location of other significant destinations within the area; and to advertise upcoming local events. They are internally illuminated, and feature a back-lit Miami River Greenway map on one side, and the opportunity to promote local events on the second side. Kiosk locations should be integrated into landscape and/or paving plans, and should not be positioned next to other street furniture such as street lights, benches, trash cans etc. to avoid conflicts and visual clutter. The kiosk should not be positioned in a way that will interfere with the natural pedestrian flow.

Features:

- Painted or Powder Coated aluminum construction.
 - Specific color scheme and graphics that complement other Greenway sign types and street furniture.
 - Internally illuminated double-sided sign cabinet. Holds 30" x 48" backlit vinyl posters (one each side).
 - Decorative cast wrap-around bases on posts. Matches those used on other Greenway sign types.
 - "Wave", "Sun" and "symbol" graphics on top of directory are water-jet cut and painted aluminum.
- Six "Miami River Greenway" symbols are used randomly atop the major sign types. Each symbol represents a different aspect of the Miami River (see page on "Miami River Symbols").



Symbol D

****Note:**
Symbols pictured were in final development at time of spec document. Please obtain final versions from City prior to manufacture.



Symbol E



Symbol F

Pedestrian Directional Sign - Project Symbols 2
Scale: 3" = 1'-0"

MIAMI RIVER *Greenway Regulatory Design Standards*

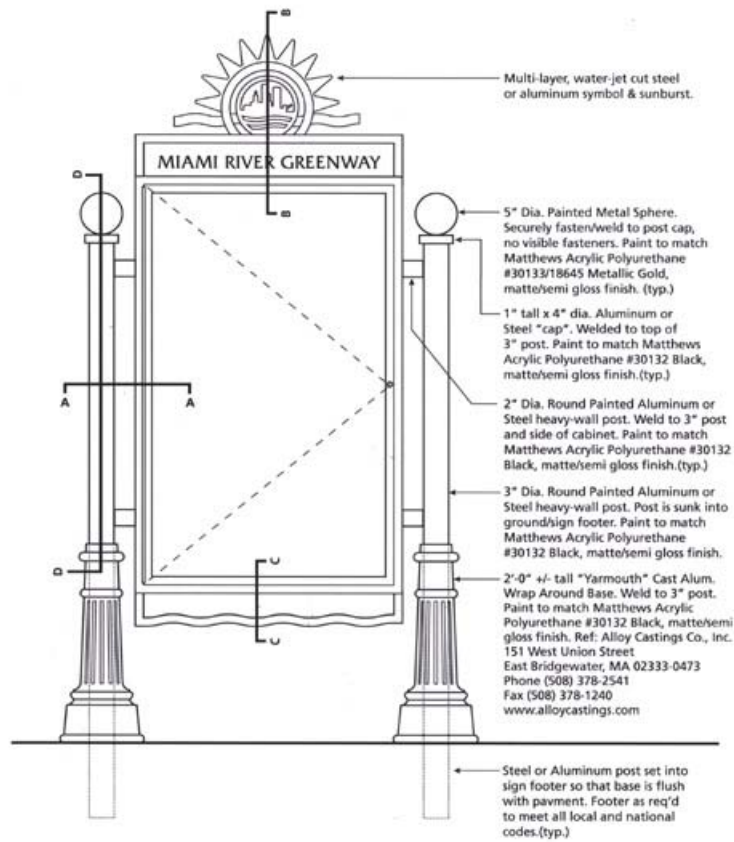

Pedestrian Kiosk - Materials & Colors: Part 1
Scale: 1" = 1'-0"

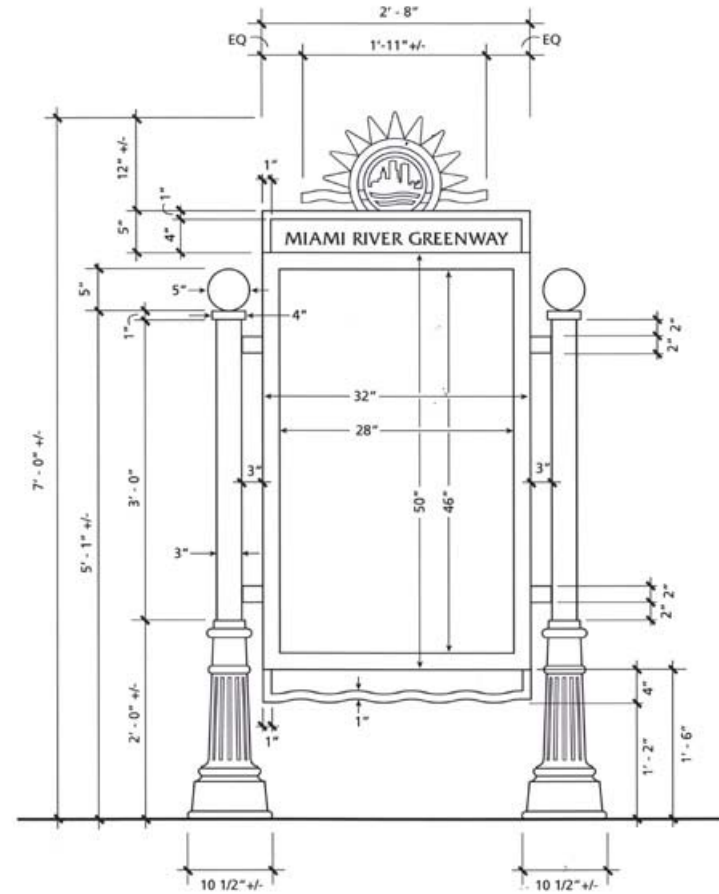

Pedestrian Kiosk - Overall Dimensions
Scale: 1" = 1'-0"

NOTE:
INTERNAL STRUCTURE AS REQUIRED.
CABINET IS TO BE WELDED STEEL
CONSTRUCTION. NO VISIBLE FASTENERS
OR SCREWS. VENTILATION AND WEEP
HOLES AS REQ'D ELECTRICAL CABLING
TO RUN THROUGH HOLLOW LEG OF
DIRECTORY, NO VISIBLE CABLING. ALL
BALLASTS ETC. TO BE INTERNAL. NO
VISIBLE SIGN COMPANY/REGULATORY
STICKERS ANYWHERE ON SIGN.

SECTION IS FOR DESIGN INTENT ONLY!
SIGN FABRICATOR TO PROVIDE SHOP
DRAWINGS AND ALL ACTUAL
CONSTRUCTION DETAILS REQ'D TO
BUILD THIS SIGN TO THE INTENT
SHOWN.

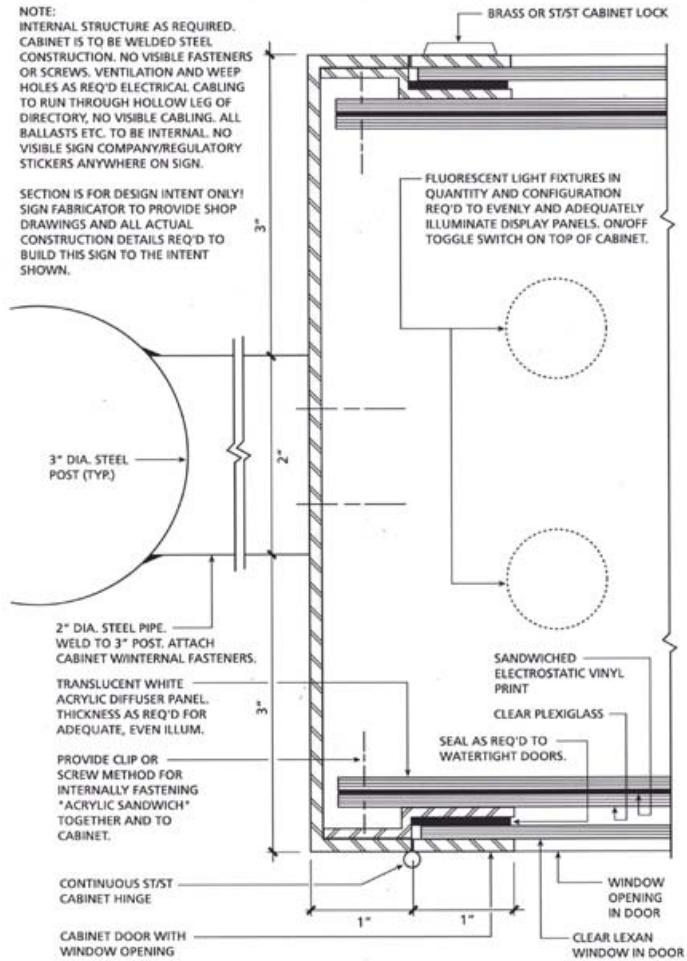

Pedestrian Kiosk - Partial Horizontal Section A-A
Scale: Actual Size

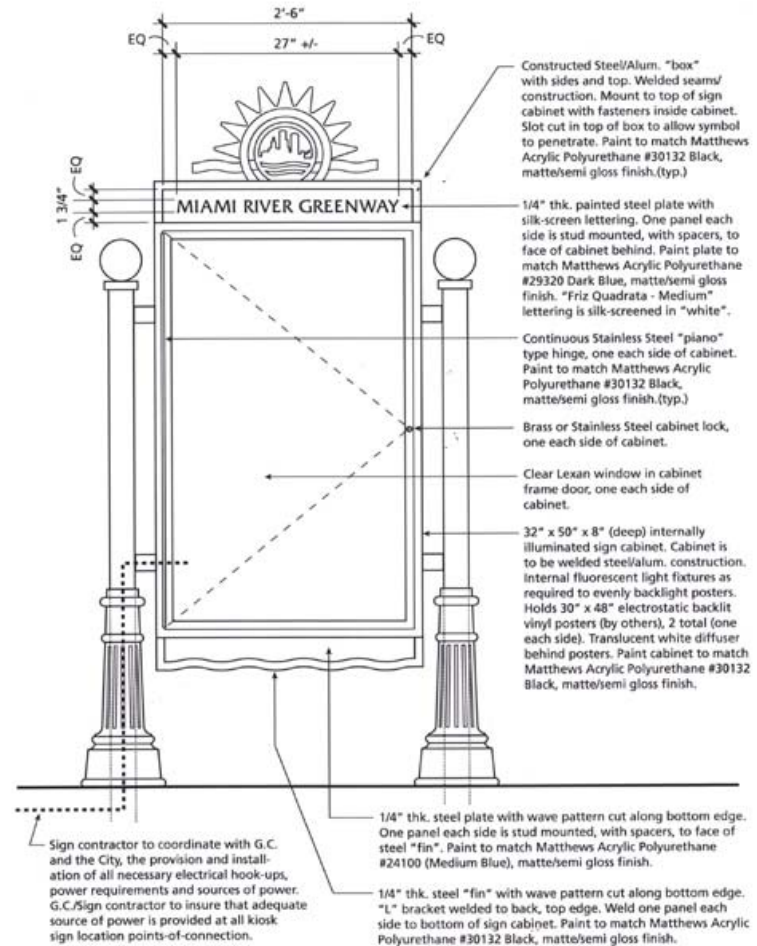

Pedestrian Kiosk - Materials & Colors: Part 2
Scale: 1" = 1'-0"

MIAMI RIVER *Greenway Regulatory Design Standards*

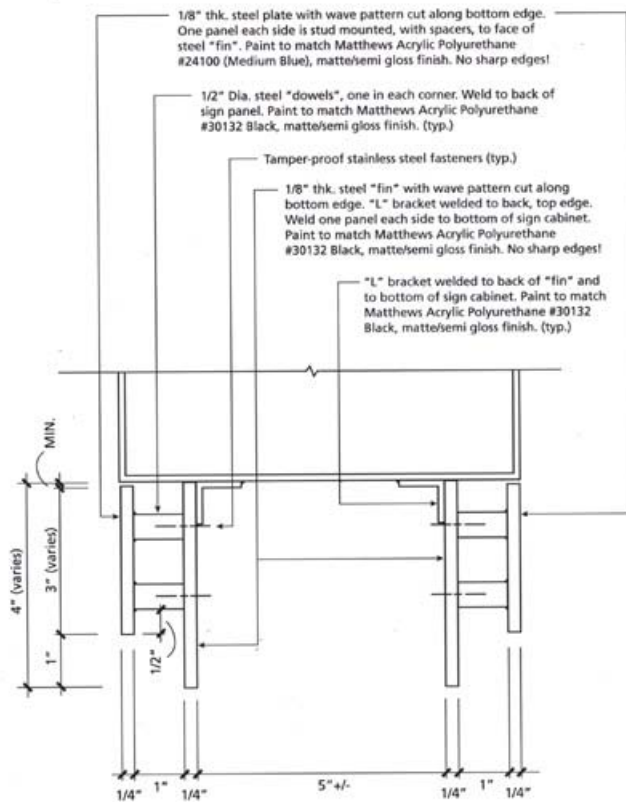

Pedestrian Kiosk - Partial Vertical Section C-C
Scale: Half Actual Size

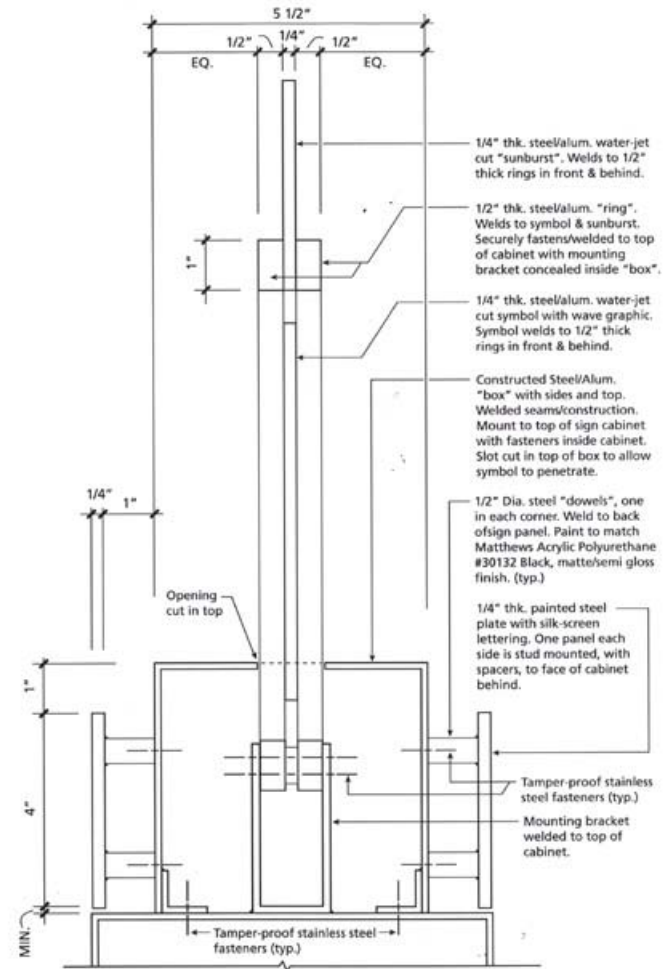

Pedestrian Kiosk - Partial Vertical Section B-B
Scale: Half Actual Size

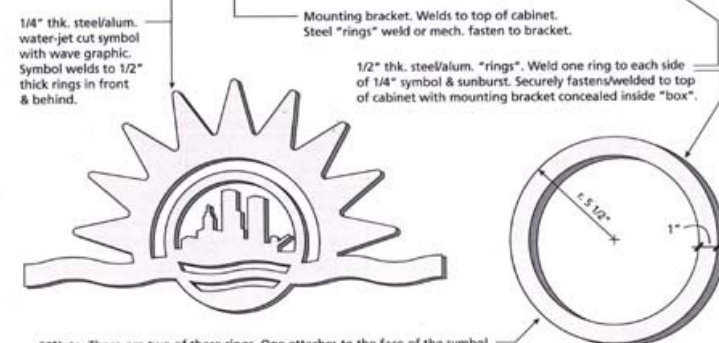
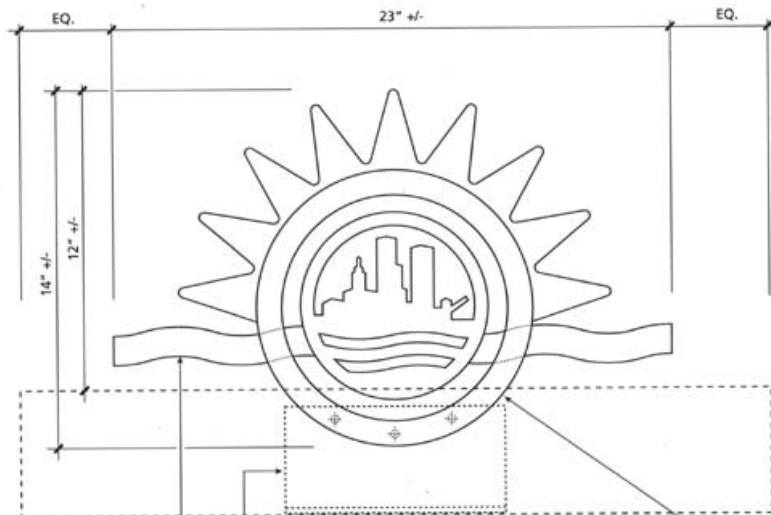

1/4" thk. steel/alum. water-jet cut symbol with wave graphic. Symbol welds to 1/2" thick rings in front & behind.

Mounting bracket. Welds to top of cabinet. Steel "rings" weld or mech. fasten to bracket.

1/2" thk. steel/alum. "rings". Weld one ring to each side of 1/4" symbol & sunburst. Securely fastens/welded to top of cabinet with mounting bracket concealed inside "box".

Pedestrian Kiosk - Symbol Construction Details
Scale: 3" = 1'-0"

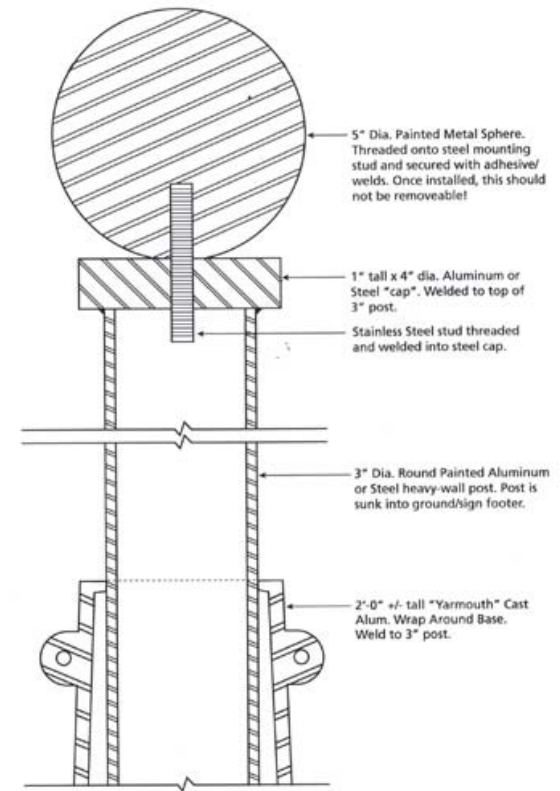

5" Dia. Painted Metal Sphere. Threaded onto steel mounting stud and secured with adhesive/welds. Once installed, this should not be removable!

1" tall x 4" dia. Aluminum or Steel "cap". Welded to top of 3" post.

Stainless Steel stud threaded and welded into steel cap.

3" Dia. Round Painted Aluminum or Steel heavy-wall post. Post is sunk into ground/sign footer.

2'-6" +/- tall "Yarmouth" Cast Alum. Wrap Around Base. Weld to 3" post.

Pedestrian Kiosk - Partial Vertical Section D-D
Scale: Half Actual Size

MIAMI RIVER *Greenway Regulatory Design Standards*

Paint "sunburst" front & back faces and edges to match Matthews Acrylic Polyurethane #30133/18645 Metallic Gold, matte/semi gloss finish. Carefully and accurately mask and spray. No hand painting!

Paint "circle & symbol" front & back faces and edges to match Matthews Acrylic Polyurethane #30132 Black, matte/semi gloss finish. Carefully and accurately mask and spray. No hand painting!

Paint "rings" all surfaces to match Matthews Acrylic Polyurethane #30132 Black, matte/semi gloss finish. Carefully and accurately mask and spray. No hand painting!

Open airspace. Metal here is cut away. (Typ.)

Paint "wave" front & back faces and edges to match Matthews Acrylic Polyurethane #24100 (Medium Blue), matte/semi gloss finish. Carefully and accurately mask and spray. No hand painting!

Open airspace (wave). Metal here is cut away. (Typ.)

(Front)



(Back)

**Note:
See "Front" above for all color specifications.

Pedestrian Kiosk - "Tree" Symbol Detail
Scale: 3" = 1'-0"

Paint "sunburst" front & back faces and edges to match Matthews Acrylic Polyurethane #30133/18645 Metallic Gold, matte/semi gloss finish. Carefully and accurately mask and spray. No hand painting!

Paint "circle & symbol" front & back faces and edges to match Matthews Acrylic Polyurethane #30132 Black, matte/semi gloss finish. Carefully and accurately mask and spray. No hand painting!

Paint "rings" all surfaces to match Matthews Acrylic Polyurethane #30132 Black, matte/semi gloss finish. Carefully and accurately mask and spray. No hand painting!

Open airspace. Metal here is cut away. (Typ.)

Paint "wave" front & back faces and edges to match Matthews Acrylic Polyurethane #24100 (Medium Blue), matte/semi gloss finish. Carefully and accurately mask and spray. No hand painting!

Open airspace (wave). Metal here is cut away. (Typ.)

(Front)



(Back)

**Note:
See "Front" above for all color specifications.

Pedestrian Kiosk - "City" Symbol Detail
Scale: 3" = 1'-0"

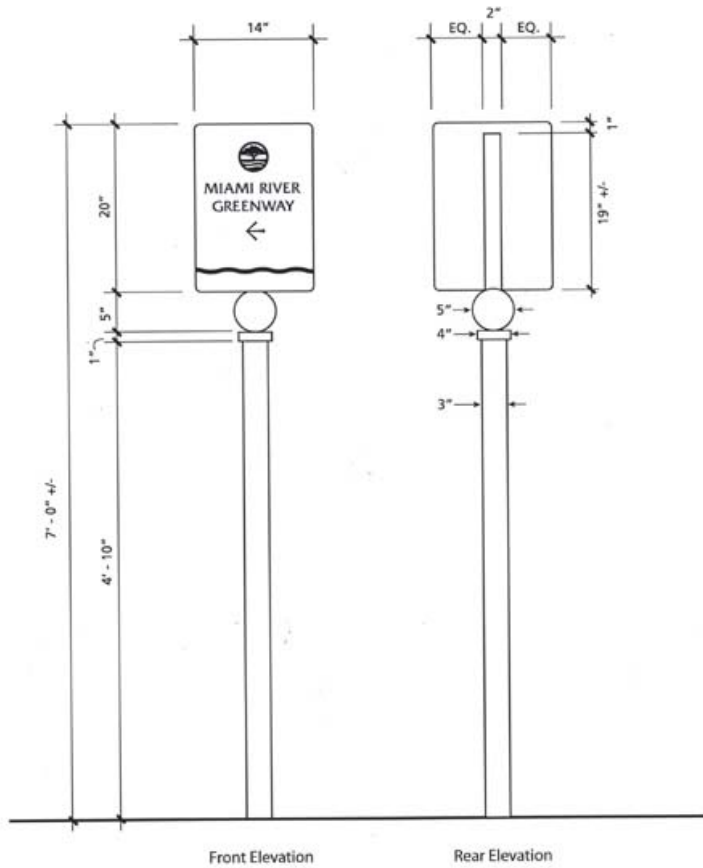

Small Directional / Information Sign - Overall Dimensions
Scale: 1" = 1'-0"

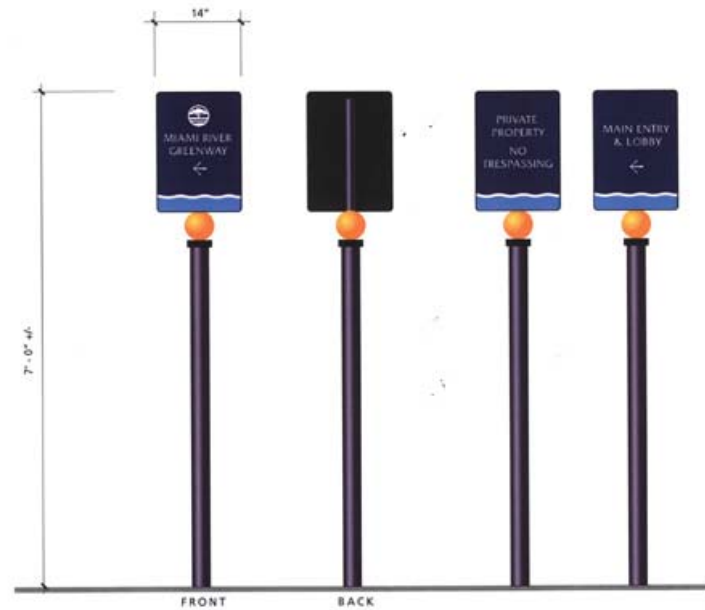

Small Directional / Information Sign:

These freestanding directional signs are located primarily along the perimeter streets and neighborhoods adjacent to the Miami River Greenway. The directional sign's purpose is to direct pedestrians to the Greenway "trail" from nearby neighborhoods; while the familiar graphics introduce and reinforce the "sense of place" in the Miami River district. This sign is also used along the Miami River Greenway in locations where minor directions are needed to steer pedestrians to the "Greenway". These signs should be used whenever public pedestrian directions are needed on streets and neighborhoods adjacent or near to the Miami River Greenway.

Features:

- Painted or Powder Coated aluminum construction.
- Specific color scheme and graphics that complement other Greenway sign types and street furniture.
- Silk-screened aluminum sign panel, with directional and/or informational text.

MIAMI RIVER Greenway Regulatory Design Standards

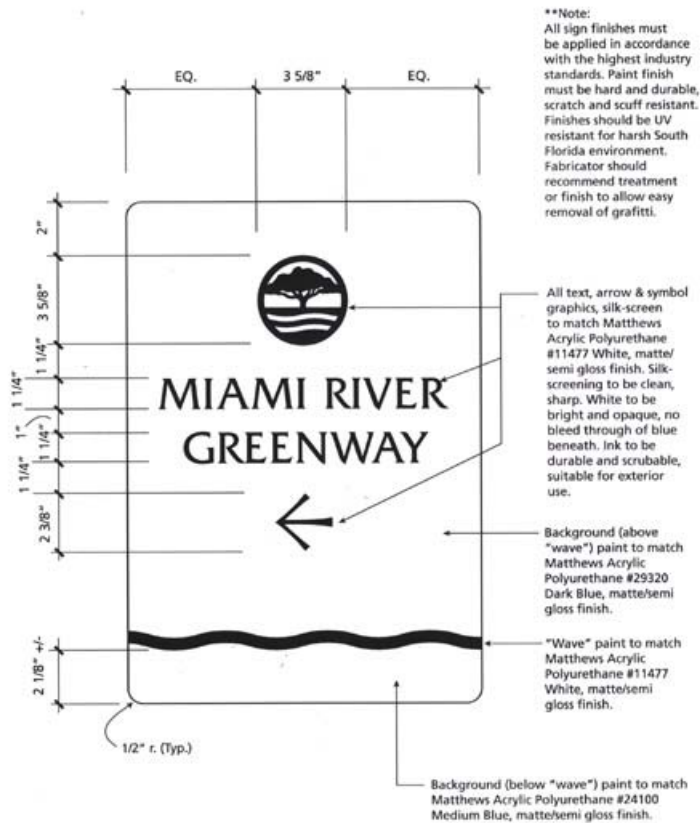

Small Directional / Information Sign - Sign Panel Dimensions
Scale: 3" = 1'-0"

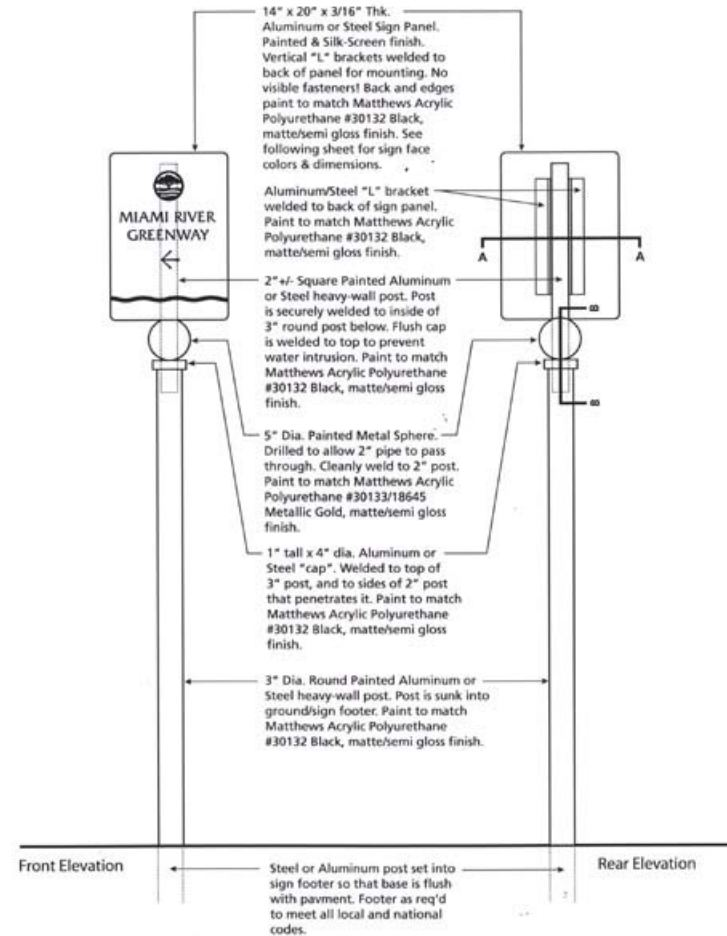

Small Directional / Information Sign - Materials & Colors
Scale: 1" = 1'-0"

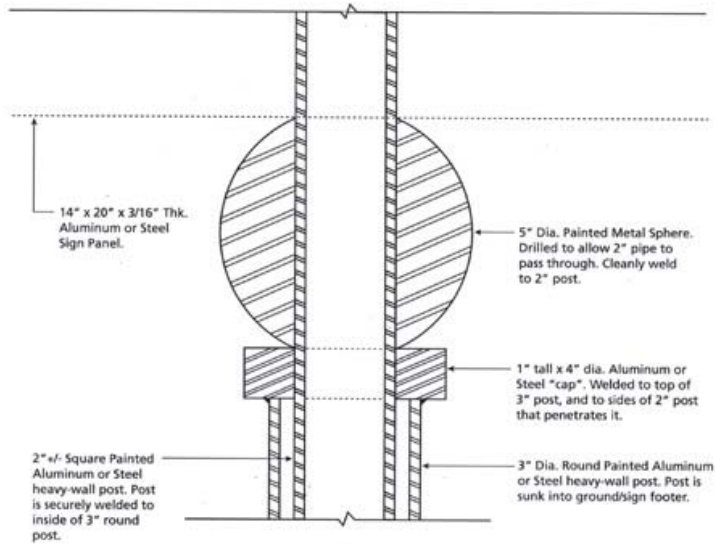

Small Directional / Information Sign - Horizontal Section B-B
Scale: Half Actual Size

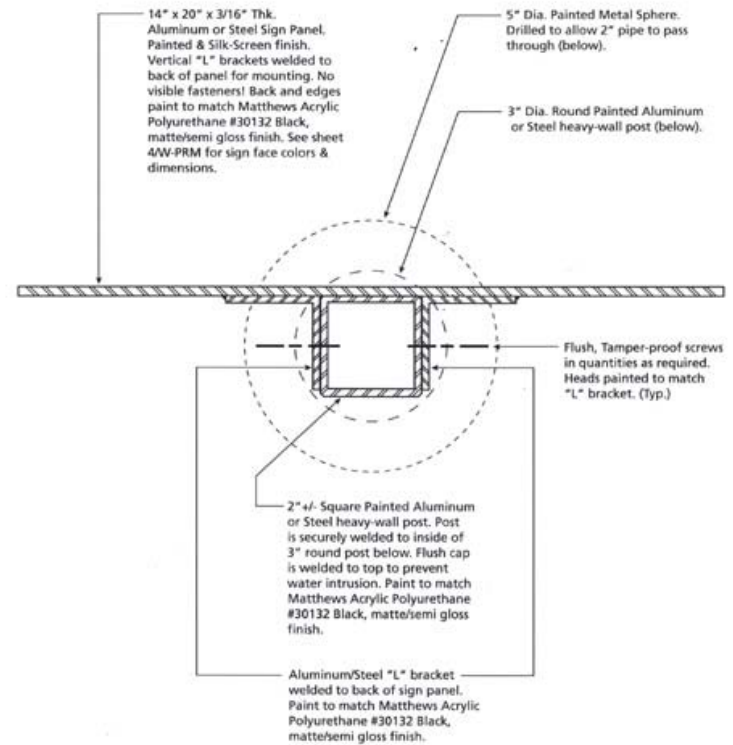

Small Directional / Information Sign - Horizontal Section A-A
Scale: Half Actual Size

MIAMI RIVER *Greenway Regulatory Design Standards*

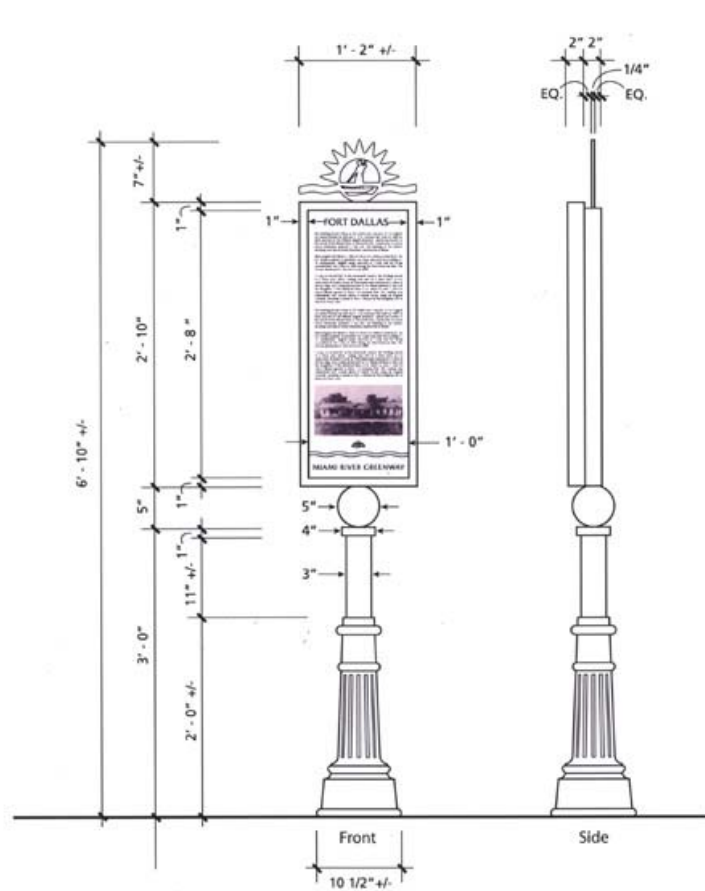

Historical Marker Sign - Overall Dimensions
Scale: 1" = 1'-0"

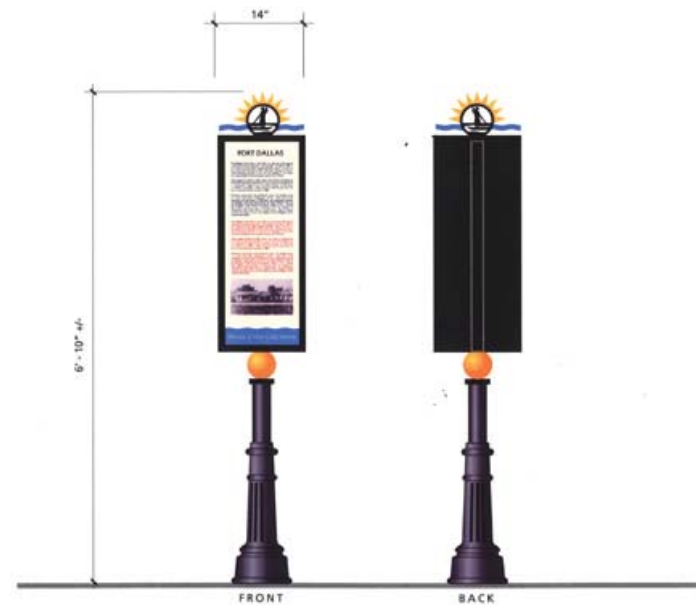

Historical Marker:

These freestanding Historical Markers are located primarily along the Miami River Greenway, and identify sites of historical significance in the area of the Miami River. The sign's purpose is to provide Greenway pedestrians and visitors with a brief historical overview of locations, structures and parks that have played an important role in the history of the Miami River. The sites are selected by the City of Miami, and collectively strive to tell the "story" of the Miami River. The location of, and use of, these signs is determined and approved by the City of Miami. These signs can be located either parallel with or perpendicular to the sidewalk. The sign should be oriented as needed to clearly identify the historical site to approaching pedestrians, but should not be positioned in a way that will interfere with the natural pedestrian flow. Signs should not be positioned next to other signs, street furniture such as street lights, benches, trash cans etc. to avoid conflicts and visual clutter.

Features:

- Painted or Powder Coated aluminum construction.
- Specific color scheme and graphics that complement other Greenway sign types and street furniture.
- Porcelain Enamel sign panel with multi-color text and photos.
- Decorative cast wrap-around bases on posts. Matches those used on other Greenway sign types.
- "Wave", "Sun" and "symbol" graphics on top of sign are water-jet cut and painted aluminum. Miami River Greenway "historical symbol" is used atop the sign (see page on "Miami River Symbols").

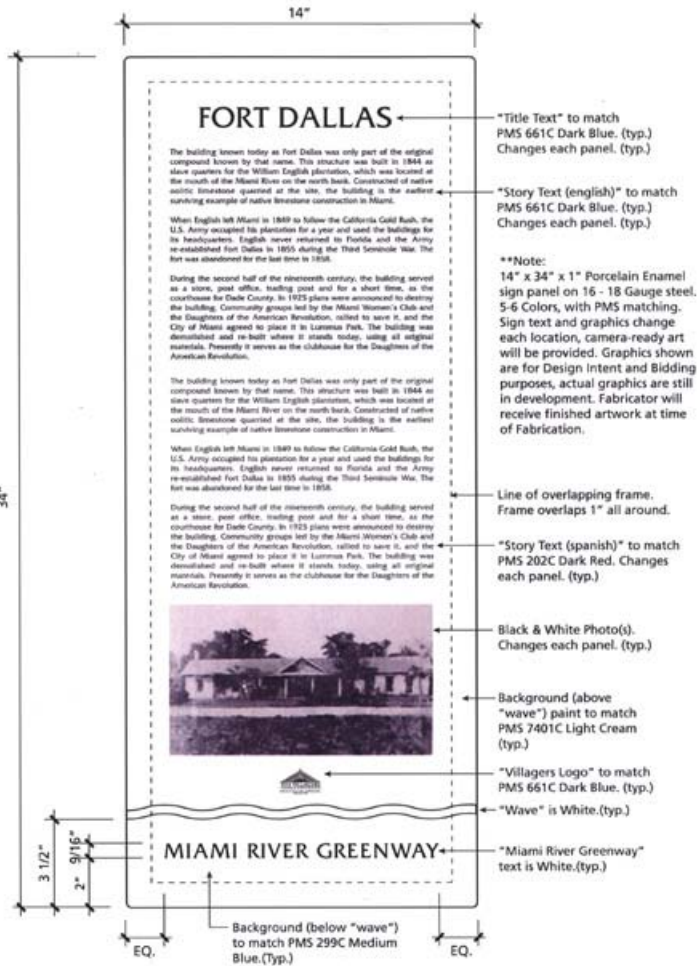

Historical Marker Sign - Typical Sign Panel Dimensions
Scale: 3" = 1'-0"

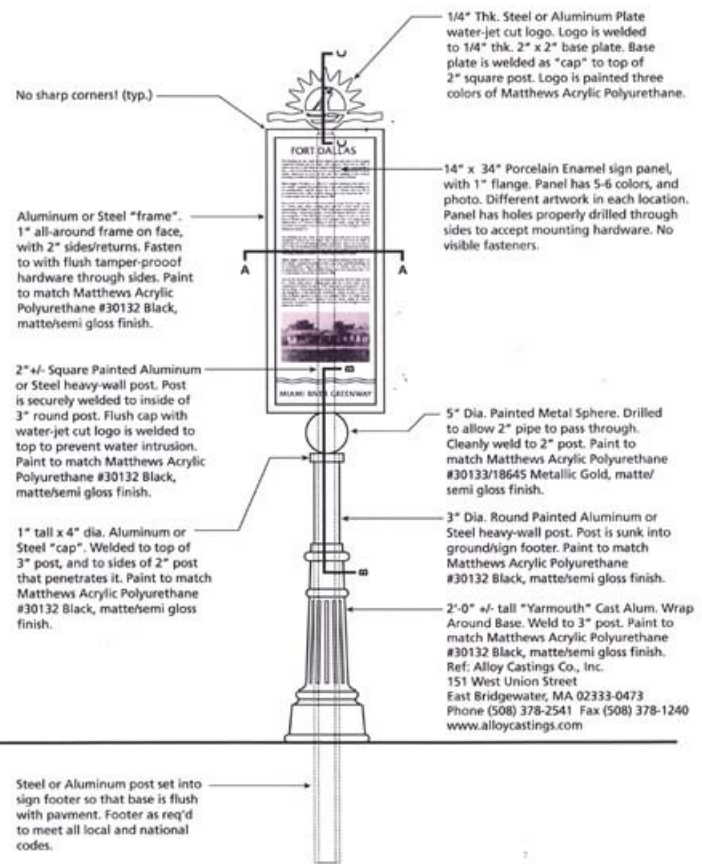

Historical Marker Sign - Materials & Colors
Scale: 1" = 1'-0"

MIAMI RIVER *Greenway Regulatory Design Standards*

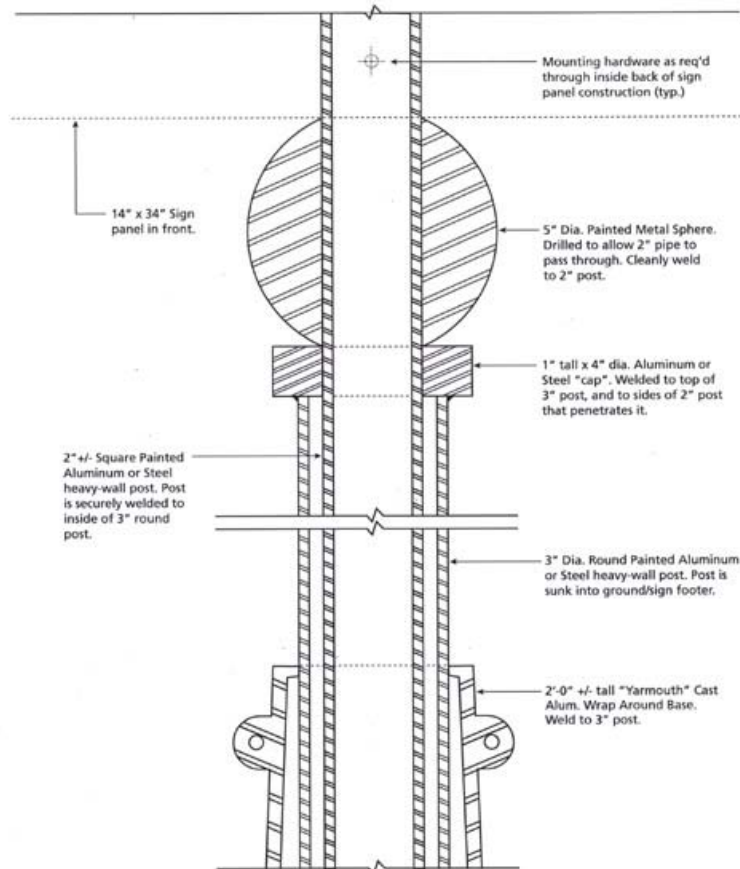

Historical Marker Sign - Partial Vertical Section B-B
Scale: Half Actual Size

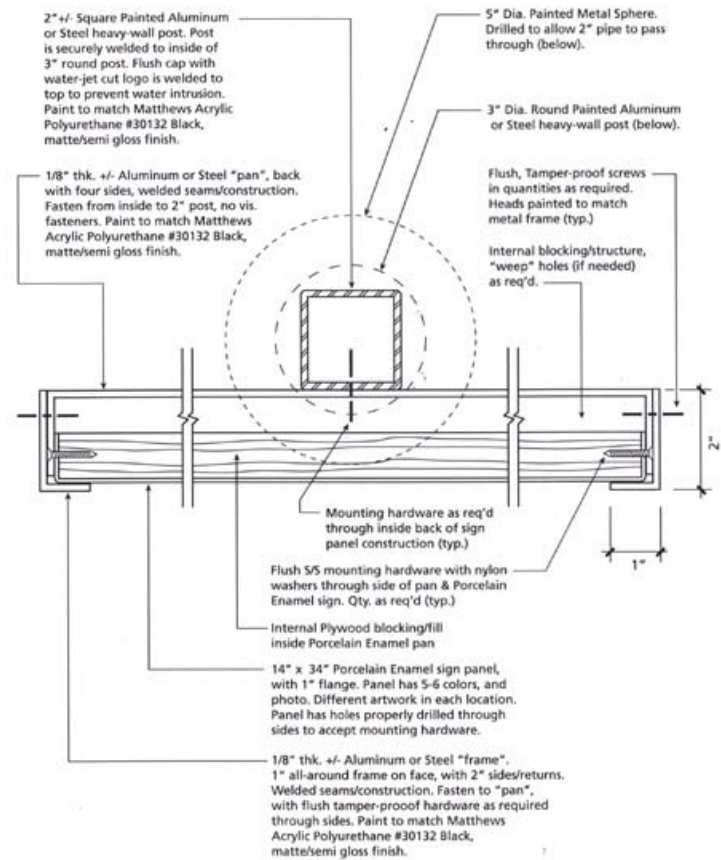

Historical Marker Sign - Horizontal Section A-A
Scale: Half Actual Size

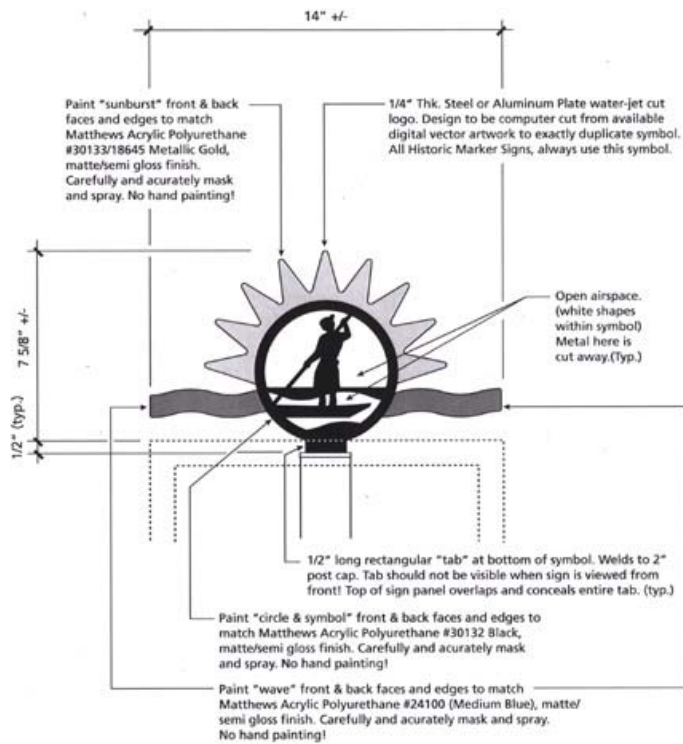

****Note:**

Symbol is water-jet cut out of (1) piece of metal plate. Color breaks are achieved by carefully masking and spraying "waves" and "sunburst". Router/laser cut masking from digital files should be used for precision. (1) sample must be supplied and approved for quality of metalwork and paint finish prior to full production.

Symbol pictured was in final development at time of spec. document. Please obtain final versions from City prior to manufacture.

Historical Marker Sign - Symbol Specifications
Scale: 3" = 1'-0"

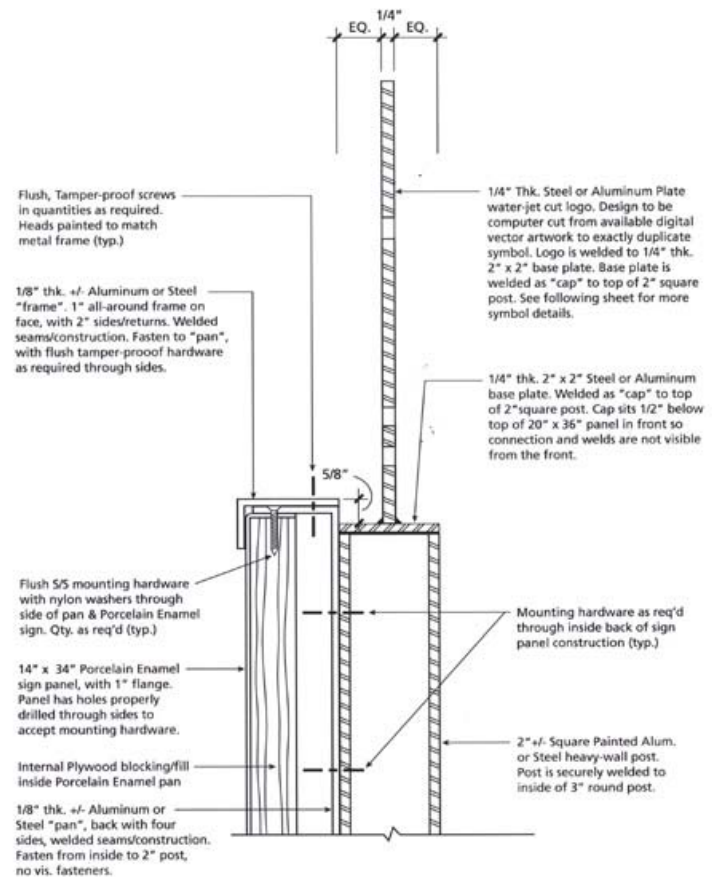

Historical Marker Sign - Partial Vertical Section C-C
Scale: Half Actual Size

MIAMI RIVER *Greenway Regulatory Design Standards*

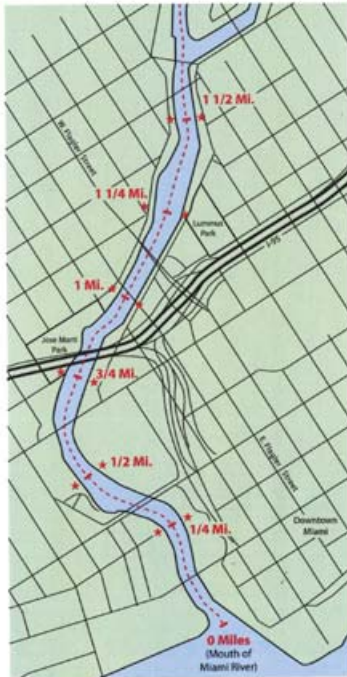

Typical Locations Along The River

Mile Marker Locations:

These Mile Markers are located in the sidewalk along the Miami River Greenway, at 1/4 mile intervals. The location of these signs is determined and approved by the City of Miami. These signs should be located in public sidewalks as close as possible to the actual measured distance. Signs should not be located in driveways, crosswalks, streets, entries etc. In the event a sign location should occur in one of this prohibited locations, the sign should be re-located to the nearest public sidewalk location. The sign should be set into and flush with the sidewalk, and must not protrude where it is a hazard to pedestrian traffic. Sign should be oriented so the number is parallel to the street.

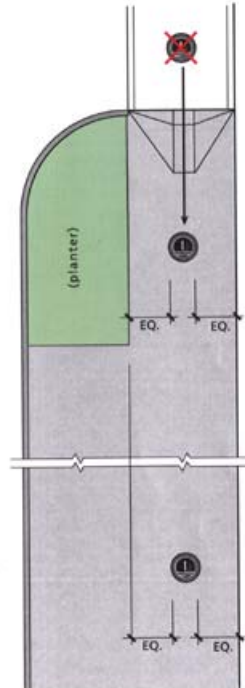

Typical Plan View

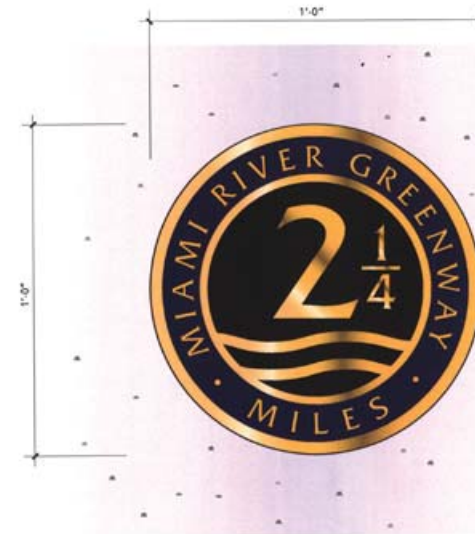

Mile Marker:

These Mile Markers are located in the sidewalk along the Miami River Greenway, at 1/4 mile intervals. The sign's purpose is to provide pedestrians with distance related reference points along the Greenway; re-inforce to pedestrians that they are following a Greenway "trail"; and to identify the Greenway and to support the "sense of place" established by other Greenway elements.

Features:

- Cast bronze with raised lettering and paint filled recesses.
- Specific color scheme and graphics that complement other Greenway sign types and street furniture.

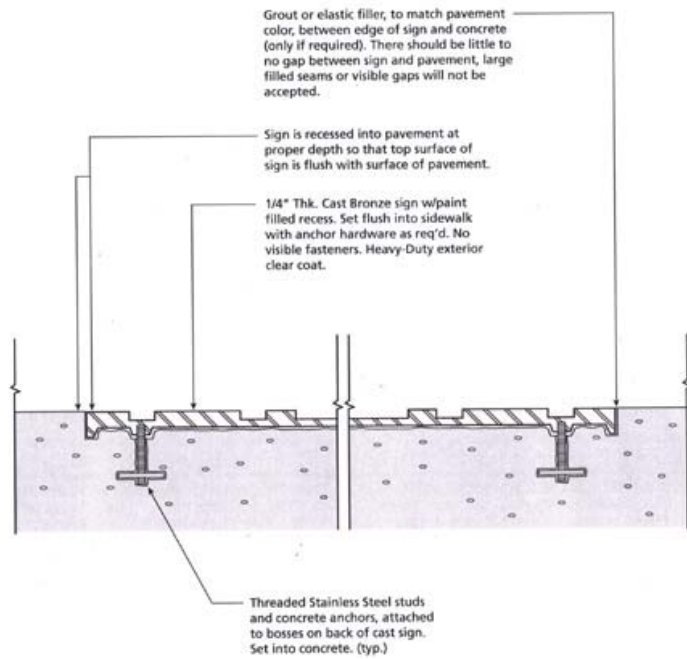

Pedestrian Mile Marker - Horizontal Section A-A
Scale: Actual Size

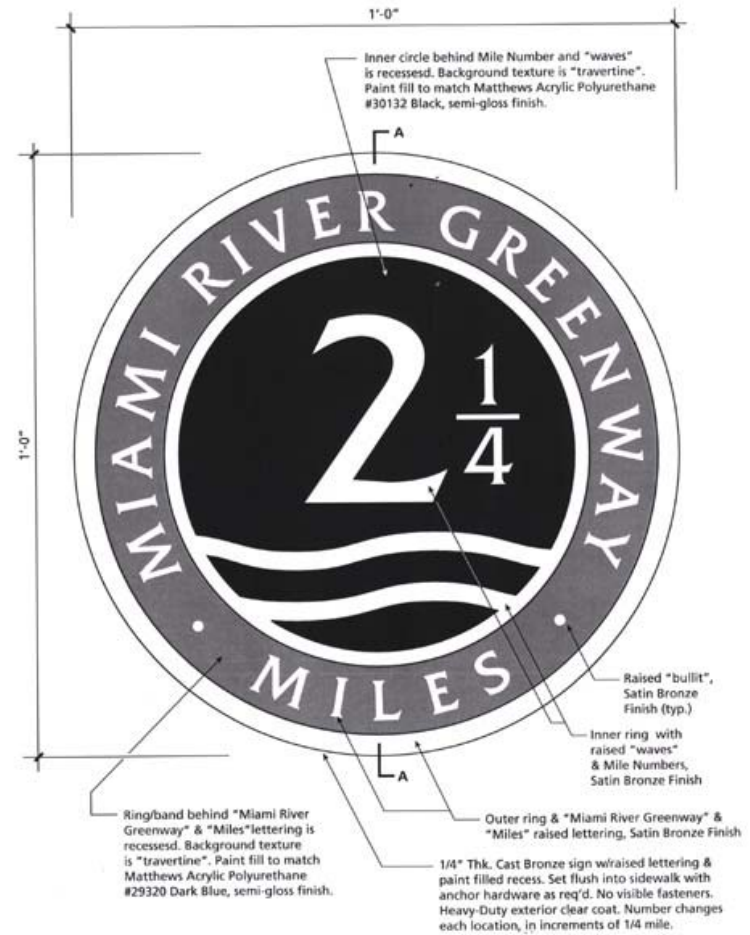

Pedestrian Mile Marker - Dimensions, Materials & Colors
Scale: Half Actual Size

APPENDIX E

CPTED GUIDELINES

From the Crime Prevention Through Environmental Design Official Website: <http://www.cpted-watch.com/>

Introduction

We live with crime every day. It has become, unfortunately, a fact of life. Discussions on the subject have traditionally focused much less on prevention than on arrest and punishment; measures that cannot be taken until after a crime has been committed.

Only in the last 20 years have designers and architects begun to see the need to plan and build with more than just the traditional threats of nature --- fire, earthquakes and hurricanes --- in mind. They must now consider the threat of crime.

Enter a new approach to crime prevention - Crime Prevention Through Environmental Design - or CPTED. Much more far-reaching than dead bolts on doors and locks on windows, CPTED principles can be applied easily and inexpensively to building or remodeling, and have been implemented in communities across the nation. The results have been impressive; in some CPTED communities, criminal activity has decreased by as much as 40 percent.

What is the secret to CPTED? Design that eliminates or reduces criminal behavior and at the same time encourages people to "keep an eye out" for each other. These are just a few of the ingredients that go into creating an effective CPTED environment... that is, a safer more livable community.

"The proper design and effective use of the built environment can lead to a reduction in the fear and incidence of crime, and an improvement of the quality of life."

CPTED as defined by the National Crime Prevention Institute

CPTED Strategies

Crime Prevention Through Environmental Design

There are four overlapping CPTED strategies.

1. Natural Surveillance

A design concept directed primarily at keeping intruders easily observable. Promoted by features that maximize visibility of people, parking areas and building entrances: doors and windows that look out on to streets and parking areas; pedestrian-friendly sidewalks and streets; front porches; adequate nighttime lighting.

2. Territorial Reinforcement

Physical design can create or extend a sphere of influence. Users then develop a sense of territorial control while potential offenders, perceiving this control, are discouraged. Promoted by features that define property lines and distinguish private spaces from public spaces using landscape plantings, pavement designs, gateway treatments, and 'CPTED' fences.

3. Natural Access Control

A design concept directed primarily at decreasing crime opportunity by denying access to crime targets and creating in offenders a perception of risk. Gained by designing streets, sidewalks, building entrances and neighborhood gateways to clearly indicate public routes and discouraging access to private areas with structural elements.

4. Target Hardening

Accomplished by features that prohibit entry or access: window locks, dead bolts for doors, interior door hinges.

Presented along with each of these CPTED strategies are guidelines which, as a homeowner, builder or remodeler, you can apply to reduce the fear and incidence of crime and improve the quality of life.



Residential areas are the heart of a city. Our homes are the centers of our lives, where we should feel most safe. And, while we may have multiple choices when it comes to walking through a certain part of town or using public transportation, we have few choices when it comes to the streets where we live.

The guiding principle here is "know thy neighbor." Street and homes should be designed to encourage interaction between neighbors: good examples of these design elements are the front porch and property lines that are defined simply by low shrubbery instead of high fences.

CPTED Guidelines

1. Natural Access Control

- walkways and landscaping direct visitors to the proper entrance and away from private areas.

2. Natural Surveillance

- all doorways that open to the outside should be well lit.
- the front door should be at least partially visible from the street
- windows on all sides of the house provide full visibility of property
- sidewalks and all areas of the yard should be well lit
- the driveway should be visible from either the front or back door and at least one window
- the front door should be clearly visible from the driveway
- properly maintained landscaping provides maximum viewing to and, from the house

3. Territorial Reinforcement

- front porches or stoops create a transitional area between the street, and the home
- property lines and private areas should be defined with plantings, pavement treatments or fences
- the street address should be clearly visible from the street with numbers a minimum of five inches high that are made of non-reflective material

4. Target Hardening

- interior doors that connect a garage to a building should have a single cylinder dead bolt lock
- Door locks should be located a minimum of 40 inches from adjacent windows
- exterior doors should be hinged on the inside and should have a single cylinder dead bolt lock with a minimum one-inch throw
- new houses should not have jalousie, casement or awning style windows
- all windows should have locks
- sliding glass doors should have one permanent door on the outside; the inside moving door should have a locking device and a pin

Subdivisions



Often the safety measures taken in subdivision communities, such as high fences and video monitored gates, can have a negative instead of positive effect on residents. CPTED guidelines, when applied to subdivisions, can create a safe environment without the use of the more common, conspicuous methods.

For instance, streets designed with gateway treatments, roundabouts, speed tables and other "traffic calming" devices discourage speed and cut through traffic. And by keeping public areas observable, you are telling potential offenders, they'd better think twice before committing a crime.

These measures are simple, inexpensive to implement and will have a much more positive effect on residents than gates and bars.

CPTED Guidelines

1. Natural Access Control

- access should be limited (without completely disconnecting the subdivision from adjacent subdivisions)
- streets should be designed to discourage cut-through traffic
- paving treatments, plantings and architectural design features such as a columned gateway guide visitors away from private areas
- walkways should be located in such a way as to direct pedestrian traffic and should be kept unobscured

2. Natural Surveillance

- landscaping should not create blind spots or hiding spots
- open green spaces and recreational areas should be located so that they can be observed from nearby homes
- pedestrian scale street lighting should be used in high pedestrian traffic areas

3. Territorial Reinforcement

- lots, streets and houses should be designed to encourage interaction between neighbors
- entrances should be accentuated with different paving materials, changes in street elevation, architectural and landscape design
- residences should be clearly identified by street address numbers that are a minimum of five inches high and well lit at night
- property lines should be defined with post and pillar fencing, gates and plantings to direct pedestrian traffic
- all parking spaces should be assigned

Multifamily



Single and Multiple Building

Multiple buildings pose the same problems as single buildings, although these problems can easily be compounded by the number of dwellings and residents. Here we have a much greater number of public areas to consider: shared interior hallways, elevators, laundry rooms and parking areas.

But multiple dwelling buildings don't necessarily mean multiple problems. There's a certain amount of truth to the old saying; "There's safety in numbers" and with neighbors who take responsibility for each other there's no reason why a multiple dwelling building cannot be a safe place to live.

CPTED Guidelines

1. Natural Access Control

- balcony railings should never be a solid opaque material or more, than 42 inches high
- entrances into parking lots should be defined by landscaping, architectural design, or monitored by a guard
- dead end spaces should be blocked by a fence or gate
- common building entrances should have locks that automatically lock when the door closes

- hallways should be well lit
- no more than four apartments should share the same entrance
- elevators and stairwells should be centrally located
- access to the building should be limited to no more than two points

2. Natural Surveillance

- exterior doors should be visible from the street or by neighbors
- all doors that open to the outside should be well lit
- all four facade should have windows
- parking spaces should be assigned to each unit located adjacent to that unit, and not marked by unit numbers
- visitor parking should be designated
- parking areas should be visible from windows and doors
- parking areas and pedestrian walkways should be well lit
- recreation areas should be visible from a multitude of windows and doors
- dumpsters should not create blind spots or hiding areas
- elevators and stairwells should be clearly visible from windows and doors
- shrubbery should be no more than three feet high for clear visibility
- buildings should be sited so that the windows and doors of one unit are visible from another
- stairwells should be well lit and open to view; not behind solid walls

3. Territorial Reinforcement

- property lines should be defined by landscaping or post and pillar fencing
- low shrubbery and fencing should allow visibility from the street
- building entrances should be accentuated by architectural elements, lighting and /or landscaping
- door knobs should be 40 inches from window panes
- all buildings and residential units should be clearly identified by street address numbers that are a minimum of five inches high, and well lit at night
- common doorways should have windows and be key controlled by residents
- mailboxes should be located next to the appropriate residences

4. Target Hardening

- since cylinder dead bolt locks should be installed on all exterior doors

- door hinges should be located on the interior side of the door
- sliding glass doors should have one permanent door on the outside and on the inside moving door should have a lock device and a pin

Commercial Properties



For a neighborhood to remain healthy, its local businesses must flourish; and for businesses to do well they must be safe places to frequent.

With the increase in separating commercial areas from residential ones, and the decline which often accompanies this separation, it is essential that CPTED guidelines be followed when building or remodeling commercial property. Simple design features, such as positioning cash registers near the main entrance and keeping pay phones visible, can accomplish much in the way of making customers feel safe and secure.

CPTED Guidelines

1. Natural Access Control

- cash register should be located in front of store near main entrance
- public paths should be clearly marked
- signs should direct patrons to parking and entrances
- there should be no easy access to the roof
- rear access to shops should be provided from rear parking lots

2. Natural Surveillance

- windows should face rear parking lots for increased visibility
- window signs should cover no more than 15% of windows
- interior shelving and displays should be no higher than five feet for increased visibility
- exterior of buildings should be well lit
- loading areas should not create hiding places
- clear visibility should be maintained from the store to the street, sidewalk, parking areas and passing vehicles
- retention area should be visible from the building or street --- it should be a visual amenity, not hedged or fenced off
- all entrances should be under visual surveillance or monitored electronically

3. Territorial Reinforcement

- property boundaries, where possible, should be marked with hedges, low fences or gates
- private areas should be easily distinguishable from public areas
- shops should be identified by wall signs for those parking in the rear
- awnings should be installed over rear doors and windows
- parking area should be, clearly visible from the building or street

4. Management

- operating hours should coincide with those of other neighboring businesses
- pay phones should be, call-out only and under surveillance at all times
- interior space should be well lit

Shopping Malls

Shopping malls often provide much of the public space in suburban communities and as such can be a mixed blessing. On the one, hand they perform the important function of town center, serving as a gathering place for the community. On the other, a mall can serve as an attraction for criminal activity.

While the shopping mall continually grows in size and popularity, it also becomes a haven for abnormal users and the site of a growing number of parking lot crimes. It is now more important than ever that designers and remodelers implement CPTED principles.

CPTED Guidelines

1. Natural Access Control

- signs should clearly mark public entrances
- sidewalks and public areas should be clearly marked by way of special paving and/or landscaping
- loading zones, with designated delivery hours, should be separate from public parking
- the parking garage should provide no exterior access to adjacent rooftops

2. Natural Surveillance

- restroom doors should be visible from main pedestrian areas and away from outside exits
- parking areas should be well lit
- loading areas should not create dead end alleys or blind spots
- all levels of the parking garage should be visible from the street or ground floor with high intensity lighting to minimize hiding places

3. Territorial Reinforcements

- property perimeters defined by landscaping, post and pillar fencing or gates
- signs should clearly identify interior businesses

4. Management

- close-in parking should be available to nighttime employees
- business associations should work together to promote shopper and business safety

Drivethroughs



The drivethrough is potentially the perfect place for criminal activity. They are often used at odd hours, are hidden from view, and those using them will almost certainly be carrying cash.

The rule of thumb in the design of a drivethrough can be reduced to one word: visibility

CPTED Guidelines

1. Natural Surveillance

- locate ATM's in front of banks facing main roads or as a drivethrough in the drive-in teller lanes
- put ordering station for a restaurant within sight of interior



The 1993 bombing of Manhattan's World Trade Center sent a clear message to the planners and designers of office buildings; as structures grow in size and pedestrian and vehicle traffic increases, safety becomes an extremely important issue,

For Years the World Trade Center served as a model for safe and secure office building construction regardless of the size of the structure being built. All tenants were required to show photo identification upon entering. Metal grill's with letter sized slits covered mail slots. Garage and loading areas were secured by steel, anti-ram barricades. *No one could have foreseen the tragic events of September 11, 2001 nor could it have been prevented by traditional security measures.*

With these types of measures, there is a fine line between a safe office building and a fortress.

CPTED Guidelines

1. Natural Access Control

- Public entrances should be clearly defined by walkways and signage
- Building entrances should be accentuated through architectural elements, lighting, landscaping and/or paving stones

2. Natural Surveillance

- restrooms should be observable from nearby offices
- all exterior doors should be well lit
- hallways should be well lit
- dumpsters should not create blind spots or hiding areas
- windows and exterior doors should be visible from the street or by neighbors
- all four facades should have windows

- parking spaces should be assigned to each employee and visitor
- parking areas should be visible from windows, side parking areas should be visible from the street
- parking and entrances should be observable by as many people as possible
- parking area and walkways should be well lit
- dumpster should be clearly visible
- shrubbery should be kept under two feet in height for visibility
- the lower branches of existing trees should be kept at least ten feet off the ground
- windows should not be obstructed with signs
- windows and doors should have views into hallways

3. Territorial Reinforcement

- perimeters should be defined by landscaping or fencing
- fences should be designed to maintain visibility from street
- exterior private areas should be easily distinguishable from public areas
- security and/or reception area should be positioned to screen all entrances

4. Target Hardening

- exterior door knobs should be a minimum of 40 inches from adjacent windows
- case hardened dead bolt locks should be installed on all exterior doors with a minimum of one-inch throw
- door hinges should be installed on the interior side of the door or tamper proof hinges used

Industrial

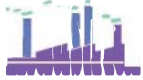

In most industrial design, the most important issue is the safety of those who will be working or travelling to these areas. Unfortunately, safety is often given little consideration. After work hour, industrial areas are, for the most part, badly illuminated, seldom under any type of surveillance, and virtually deserted, which in itself be problem enough. Add to this isolation the industrial danger areas, loading docks, service entrances, blind alleys and expansive parking areas and you have the potential for an extremely unsafe environment.

CPTED Guidelines

1. Natural Access Control

- dead ends should be avoided
- site entrances should be easily securable
- entrances to parking areas should be controlled by fence, gate or attendant
- parking should be assigned by shifts and planned to favor late workers with close-in spaces
- pedestrian and vehicular direct access to railroad tracks should be restricted
- storage yards should be planned for vehicular access by patrol car
- access to roofs via dumpster, loading docks, poles, stacked items etc. should be restricted
- building entrances should be kept to a minimum
- delivery entrances should be separate, well-marked and monitored
- employee entrance should be close to employee parking and work areas
- nighttime parking should be separate from service entrances
- access to one area of building should not allow access to others
- access should be provided to both front and back so that building can be patrolled

**

2. Natural Surveillance

- all entrances should be well lit, well defined and visible to public and patrol vehicles
- parking area should be visible to patrol cars, pedestrians, parking attendants and/or building personnel
- parking attendant should be positioned for maximum visibility of property
- reception areas should have a view of parking areas
- walls should be used only where necessary and should be high enough to prevent circumvention
- blind alleys, storage yards, etc. should not create hiding places

3. Territorial Reinforcement

- gateway effect or formal entrance should be created with planting, fences, gates, etc
- delivery hours should be limited to daytime hours
- vehicle entrances should be defined by different paving materials and signage

4. Target Hardening

- delivery bays should be secured with locks

5. Management

- operating hours should be the same as those of neighboring businesses

** Since the implementation of the Federal Maritime Security Act in July, 2004, all river shipping terminals have lighting and video camera systems, and are patrolled 24 hours per day, 7 days per week.

Parking Garages/Structures

Studies show that in both urban and suburban environment, parking structures are the most problematic. These structures isolate people. Most garages are not only badly designed - with many blind spots and hiding areas - but badly maintained as well.

CPTED guidelines can do much in the way of improving parking structure safety without tremendous cost. With the simple addition of high intensity lighting, for example, a garage can quickly become a much safer place.

CPTED Guidelines

1. Natural Access Control

- garages should be attended or monitored openly with cameras and sound monitors indicated with signs
- pedestrian entrances should be adjacent to vehicle entrances
- stairwells should be visible without solid walls
- elevators should be close to the main entrance with the entire interior of the elevator in view when the doors are open
- there should be no permanent, stop button installed in elevators
- ground floor should be design to provide a view of the garage using wire mesh or stretch cable
- access should be limited to no more than two designated, monitored entrances

2. Natural Surveillance

- all elevators should be monitored by cameras and sound or utilize clear materials for the entire car
- retaining walls should be replaced with stretched cable railings for maximum visibility
- parking areas and driving lanes should be well lit

3. Management

- there should be no free access to adjacent building without direct monitoring
- public and private parking spaces should be designated
- hours of use should reflect that of local businesses, with secure closing during non-use hours

Conclusion

Crime Prevention Through Environmental Design guidelines can go a long way in making an environment safe. As stated earlier, criminal activity in CPTED cities is on the decline, but these principles alone cannot make, and more importantly keep, a community safe.

CPTED can eliminate problem areas: the badly lit parking lot, the blind alley and the public telephone stuffed in the dark corner. Hopefully, along with the feelings of safety and security that CPTED brings, will come a feeling of responsibility for our neighbor. That is the greatest crime prevention technique of all.

"CPTED is not the total answer to Community problems, but it does provide the community with the mean to eliminate or reduce environmental obstacles to social, cultural or managerial control!"

Timothy D. Crow

Criminologist & CPTED Practitioner

APPENDIX F

Landscape Maintenance

The designer should choose landscape design form and materials to reflect a long term commitment aesthetically by emphasizing the “classic” and avoiding the “vogueish” and trendy.

- Maintenance shall include watering, weeding, fertilizing, cultivating, spraying, adjustment of guying, staking, and pruning necessary to keep plant materials in a healthy, vigorous, growing condition and to keep plant areas neat and attractive.
- Use vegetation that is long-lived, hardy, insect and disease resistant and requires low maintenance.
- Choose materials that complement each other and any existing material, particularly the outdoor surface material and the surrounding architectural structures.
- Employ these materials in a logical manner in full knowledge of the inherent characteristic of the material and the underlying construction and installation techniques.
- Do not plant species in the DERM prohibited species list and City of Miami Code of Ordinances prohibited species list.
- Property owners are responsible for maintaining the landscape in their property. This includes keeping all bed clear of debris and dead foliage, as well as supplying an automatic irrigation system providing 100% coverage.
- All plant material planted along right-of-ways shall be Florida #1 or better.

APPENDIX G

DESCRIPTION OF JURISDICTIONAL ACTIVITIES AND REQUIRED APPROVALS

Background/Intent

The Miami River itself is perhaps the biggest asset of the corridor. This dynamic, multi-purpose body of water serves as a vital business link to this city and also as an ever growing recreational amenity. This section focuses on outlining several potential scenarios for water-related improvements and the regulatory agencies and steps necessary to permit this improvements.

Refer to Appendix G for the steps and agencies involved in the following scenarios:

- Replace an existing seawall in the same location
- Replace an existing seawall in a different location
- Build a new seawall
- Build a new deck
- Replace an existing deck



Riverwalks are great amenities for cities. They provide escape from the urban environment by bringing people closer to the water and have the potential to generate a variety of commercial, residential and recreational opportunities.

Key Map

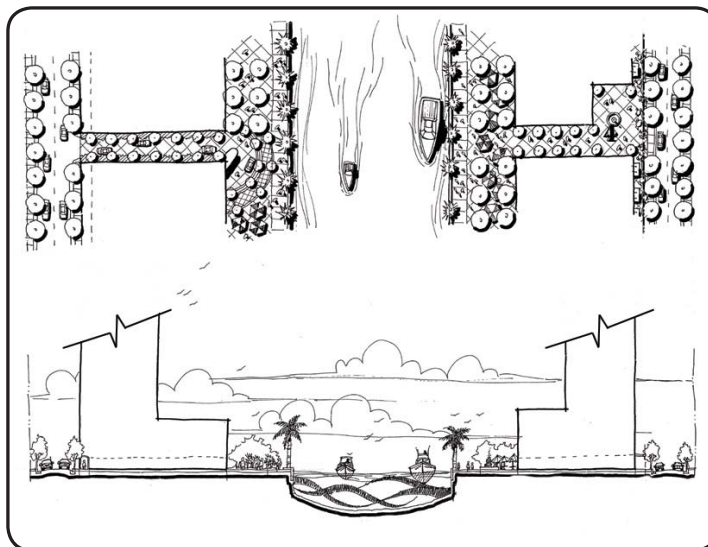

DESCRIPTION OF JURISDICTIONAL ACTIVITIES AND REQUIRED APPROVALS

1.0 Jurisdictional Control

1.1 Federal Jurisdictional Activities

Federal jurisdictional activities are comprised of any project proposing activities (i.e. construction associated with a project) that may potentially impact one or more federally maintained navigation channels, submerged lands and/or water of the United States that are under the regulatory authority of Section 404 of the Clean Water Act, Section 10 of the Rivers and Harbors Act, The Endangered Species Act, The Marine Mammal Protection Act and The Magnuson-Stevens Fishery Conservation and Management Act.

The channel in the Miami River is maintained by the United States Army Corps of Engineers (USACE). Any activity within the right-of-way of the channel and within the navigable waters of the Miami River will require authorization from the USACE. Authorization to dredge or place fill in these areas will be in the format of a Section 10 permit.

Any construction that will result in impacts to the navigation channel will also require authorization from the United States Coast Guard (USCG). The USCG will be primarily concerned with impacts to security and impacts to commerce (navigation hazards). The USCG may issue a Notice to Mariners describing the activities that will be occurring and any potential disruptions to navigation.

The National Marine Fisheries Service (NMFS) is a federal agency that has jurisdiction over designated marine fisheries. NMFS will be consulted by the USACE during the federal permitting process.

The United States Fish and Wildlife Service (USFWS) is a federal agency that has jurisdiction over federally protected threatened and endangered species. USFWS will be consulted by the USACE during the federal permitting process.

Other federal agencies may be consulted by the USACE during the federal permitting process; however, all of these agencies are commenting agencies. Only the USACE has regulatory authority and they issue the required permit.

1.2 State Jurisdictional Activities

The Miami River is a jurisdictional surface water body as defined under Chapter 62-340.600 Florida Administrative Code (F.A.C.) and Chapter 40E-4 Florida Statutes (F.S.) All activities in, on or under wetlands or submerged lands will require approval from the State.

Permits to impact state jurisdictional waters are issued by either the South Florida Water Management District (SFWMD) or the Florida Department of Environmental Protection (FDEP).

The Florida Fish and Wildlife Conservation Commission (FWC) will provide comments the FDEP regarding potential impacts to State listed threatened and/or endangered species. The FWC is a commenting agency only, but may require a cultural resources survey of areas where construction is proposed.

The Department of State, State Historic Preservation Office (SHPO) will provide comments to the SFWMD/FDEP regarding potential impacts to cultural and/or historical resources. SHPO is a commenting agency only.

1.3 Miami-Dade County Jurisdictional Activities

The Department of Environmental Resources Management (DERM) is responsible for protecting, restoring, enhancing, conserving, and managing the air, water, and land resources of Miami-Dade County. DERM was granted regulatory authority by Chapter 24, Article II of the Miami-Dade County Code of Ordinances (which incorporates by reference, Chapter 40E-40 F.S.). Impacts to coastal (tidal) wetlands will require a Class I permit from DERM.

Impacts to jurisdictional waters and natural resources, which include wetlands will require permits from all three agencies. The applications will be submitted simultaneously and the agencies will review them concurrently.

2.0 Types of Approvals

2.1 Replacement of an Existing System

The level of regulatory scrutiny of a project varies based upon the amount of proposed impacts to the environment. If the applicant proposes to replace an existed previously permitted, currently serviceable structure (seawall, revetment, etc.) within one foot waterward of the alignment of the previous structure, the applicant can obtain an exemption from the State and a Nationwide Permit No. 3 from the USACE and a Class I permit from DERM. “Currently serviceable” means “useable as is or with some maintenance, but not so degraded as to essentially require reconstruction.”

Approximate permitting time for this type of activity can range from 12 to 15 months. However, permit times can vary considerably based on the overall upland development plans.

2.2 Placement of a New Structure

If the applicant proposes to place a seawall (new or as a replacement) further than one foot waterward of the Mean High Water line (MHW), a higher level of review will be required by the agencies. It is likely that proposed activity will require either a general or an individual permit from the State and USACE and a Class I permit from DERM. If the activity occurs on sovereign submerged state lands, an easement, consent of use, or similar instrument may be required.

Approximate permitting time for this type of activity can range from 15 to 18 months. Again, permit times can vary considerably based on the overall upland development plans.

If the applicant proposes to place the structure landward of MHW, entirely in uplands, and there are no impacts to listed species, permits from the above agencies are not required. It should be noted that the burden for proof is on the applicant to demonstrate that the proposed activities are not within jurisdictional areas.

2.3 Placement of a Boardwalk/Pier

2.3.1 Placement of a New Structure

The construction of a boardwalk or pier for the purposes of providing pedestrian access to the water and the mooring of boats will be reviewed and authorized through the same process as described above. This type of activity is considered an impact to jurisdictional waters and will require permits from all three agencies described in Section 1.0.

Generally, the placement of a structure, such as a pier, within 100 feet of the limits of the federally maintained channel is not permitted. If the applicant proposes to place a structure within the right-of-way of the channel, the placement of additional aids to navigation may be required.

2.3.2 Repair of an Existing Boardwalk/Pier

The repair and/or replacement of an existing boardwalk/pier would fall under the same regulations and requirements described in Section 2.1.

2.3.3 Placement of Fill Within the Right-of-Way

The placement of fill within the channel right-of-way would require the same authorization as described in Sections 2.2 and 2.3.1.

3.0 Environmental Constraints, Avoidance, Minimization and Mitigation

Section 404 of the Clean Water Act, Section 10 of the Rivers and Harbors Act, Chapter 40E of Florida Statutes (F.S.) and Chapter 24, Article II of the Miami-Dade County Code of Ordinances (which incorporates by reference, Chapter 40E-40 F.S.), places restrictions on activities that can occur in, on, over, or under wetlands, surface waters, federal navigation channels and other natural resources. These resources include Submerged Aquatic Vegetation (SAV) and hard-bottom communities.

These restrictions state that proposed projects should avoid, to the greatest extent practicable, the above referenced natural resources. Projects should incorporate design modifications and construction methodologies that meet avoidance criteria. Steps taken to avoid natural resources should be documented during the permitting process.

If resources cannot be avoided, impacts must then be minimized. Minimization in this case may be minor adjustments in the routes to “go around” resources. This can only be done if a natural resources survey is completed within the route corridor.

Finally, if impacts to resources are determined to be unavoidable, the agencies will allow the applicant to mitigate for these impacts. As of February 1, 2004, State regulatory agencies adopted the Unified Mitigation Assessment Method (UMAM). When using UMAM, the applicant assesses a resource’s functional value then multiplies that value by the area of impacts. This establishes the functional loss. That functional loss must be compensated for through mitigation. This method is described fully in Chapter 62-345.400 F.A.C.

The USACE uses similar methodology to determine required mitigation known as the Wetland Rapid Assessment Procedure (WRAP). WRAP is fully described in the USACE Wetland Delineation Manual (1984.)

In order to utilize either UMAM or WRAP, the natural resource area must be surveyed and assessed in the field. These assessments will be reviewed by the relevant agencies during the permitting process.

APPENDIX H

Case Studies

The following pages illustrate three of the comparable design guidelines. Although each set of guidelines is different, there are many similarities and common traits that apply to the Miami River standards. Such elements include setbacks, access, safety, pedestrian feel and relationships between public and private spaces. While the intent of this document is not to follow the method and application directly, it does draw on the more relevant and appropriate concepts developed and prove in these studies to substantiate the guidelines proposed herein. The one important element all of these studies share is that they have been made into enforceable ordinances. This crucial step is the ultimate goal of these standards.

CASE STUDY 1

City of Fort Lauderdale Design Guidelines

These guidelines aimed to achieve broad goals, which would guide designers in a qualitative approach when working with built form.

The guidelines were divided into four sections:

1. Principles of Street Design
2. Principles of Building Design
3. Character Area Guidelines
4. Street Design Examples



Above: 3-D image of proposed improvements to Broward Boulevard

“The next period of growth can transform Downtown into a truly livable urban center, with diverse, healthy residential neighborhoods. It can knit together the urban fabric into a seamless pattern of walkable, beautiful streets, public spaces, and buildings of the highest quality. It can combine an energy and optimism of a rapidly growing city with a balanced approach that tackles the serious challenges of traffic, parking, transit, schools, and infrastructure. The City must focus on all of these issues to create a fully livable Downtown, and to achieve the long-term economic sustainability that would accompany it...As the vision is implemented, the details of the Master Plan will change and adapt to unforeseen circumstances, but its core planning principles should be maintained. The next natural step of Fort Lauderdale’s evolution is Building a Livable Downtown.”

– City of Fort Lauderdale, Florida, 2003

On November 18, 2003, the Fort Lauderdale City Commission accepted the Consolidated Downtown Master Plan by resolution. Now, all Downtown development proposals seeking dwelling units in excess of the 5,100 dwelling units that were originally permitted by the 1989 Broward County Land Use Plan must be evaluated by the Design Review Team and ultimately approved by the City Commission. In addition to meeting all of the requirements of the ULDR for the type and location of the development proposed, all proposed projects must demonstrate consistency with the design guidelines outlined in the Consolidated Downtown Master Plan or provide reasonable design alternatives that still further the intent of the design guidelines.

Primary Purpose:

The primary purpose of the Master Plan was to address key issues, guide future growth, development and public investment in Downtown, and maintain and enhance quality of life for those who live, work and visit the heart of Fort Lauderdale.

Web Link: <http://ci.ftlaud.fl.us/MasterPlan>

CASE STUDY 2

San Antonio River Improvements Project

Thirteen miles of urban river occur beyond the downtown area along the San Antonio River. These areas have previously not been addressed and have tremendous potential.

The design guidelines for this area include the following five visions:

1. Access needs for the southern reach
2. Uses of the river
3. Water quality and quantity issues
4. Safety and maintenance
5. Special Concerns



Above: Artist's rendering of proposed river improvements

“The San Antonio River Design Guidelines set the design vision for the river that will be implemented over the first decade of the 21st century. These guidelines establish the major framework in which future design consultants’ work will be undertaken. Each project reach will be designed with the intent of these guidelines to ensure that the vision’s concepts are being realized in the vocabulary that has been established. When completed, the river improvements will be a consistent and coherent system.”

– San Antonio River Design Guidelines, 2001

“The San Antonio River Improvements Project Concept Design Guidelines, the River Walk Policy Guidelines, as amended, and the Design Guidelines for Development of Properties along the San Antonio River, prepared for the City of San Antonio, are hereby adopted as policy guides for use by the commission and property owners.”

– Excerpt from City of San Antonio Code

Primary Purpose:

The San Antonio River Improvements Project is a 10-year, \$140 million investment by the City of San Antonio, Bexar County and the Corps of Engineers in flood control, amenities, ecosystem restoration and recreational improvements to the San Antonio River, both north and south of downtown San Antonio.

– Excerpt from the San Antonio River Improvements Project.

Web Link: <http://www.sanantonioriver.org>

CASE STUDY 3

Fort Lauderdale Riverwalk

These guidelines aimed to achieve broad goals, which would guide designers in a qualitative approach when working with built form.

The guidelines were divided into four sections:

1. Principles of Street Design
2. Principles of Building Design
3. Character Area Guidelines
4. Street Design Examples



Above: Shade structure along the Riverwalk.

On November 18, 2003, the Fort Lauderdale City Commission accepted the Consolidated Downtown Master Plan by resolution. Now, all Downtown development proposals seeking dwelling units in excess of the 5,100 dwelling units that were originally permitted by the 1989 Broward County Land Use Plan must be evaluated by the Design Review Team and ultimately approved by the City Commission. In addition to meeting all of the requirements of the ULDR for the type and location of the development proposed, all proposed projects must demonstrate consistency with the design guidelines outlined in the Consolidated Downtown Master Plan or provide reasonable design alternatives that still further the intent of the design guidelines.

For more information regarding the Riverwalk project, contact the City of Ft. Lauderdale at 954-828-6885.